

Thank you for purchasing this RKC product. In order to achieve maximum performance and ensure proper operation of your new instrument, carefully read all the instructions in this manual. Please place this manual in a convenient location for easy reference.

1. OUTLINE

Using the setting examples below, this section explains the configuration when SRZ unit is connected to a programmable controller (PLC). In addition, PLC communication environmental settings are required to communicate with the PLC. The PLC communication environmental settings are set by the loader communication (Environmental settings can also be made in the host communication), so the personal computer, USB communication converter COM-K and SRZ unit must be connected.

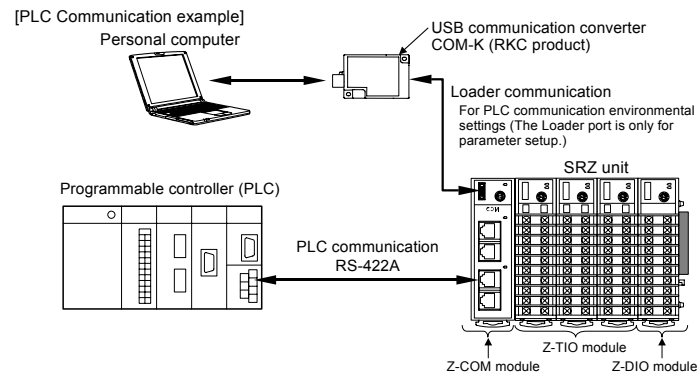

This manual describes the preparation for conducting PLC communication between the Z-COM and PLC. For the data map, host communication, the installation, the detail handling procedures and various function settings, please read if necessary the following separate manuals.

- Z-COM Installation Manual (IMS01T05-E□): Enclosed with Z-COM
- Z-COM Host Communication Quick Instruction Manual (IMS01T09-E□): Enclosed with Z-COM
- Z-COM PLC Communication Data List (IMS01T15-E□): Enclosed with Z-COM
- Z-COM Instruction Manual (IMS01T22-E□): Separate*
- Z-COM Host Communication Instruction Manual (IMS01T23-E□): Separate*
- Z-TIO INSTRUCTION MANUAL (IMS01T01-E□): Enclosed with Z-TIO
- Z-TIO Host Communication Quick Instruction Manual (IMS01T02-E□): Enclosed with Z-TIO
- Z-DIO INSTRUCTION MANUAL (IMS01T03-E□): Enclosed with Z-DIO
- SRZ Instruction Manual (IMS01T04-E□): Separate*

*Download or sold separately

The above manuals can be downloaded from our website:
 URL: http://www.rkcinst.com/english/manual_load.htm

2. HANDLING PROCEDURES

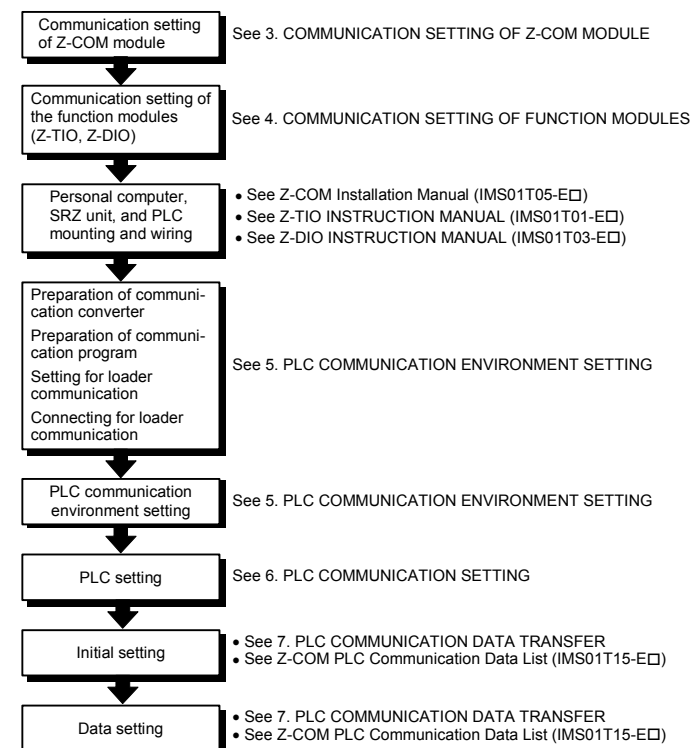

3. COMMUNICATION SETTING OF Z-COM MODULE

Set communication setting before mounting and wiring of the Z-COM.

CAUTION

Do not separate the module mainframe from the base with the power turned on. If so, instrument failure may result.

3.1 Unit Address Setting

Set an address for the SRZ unit using a small blade screwdriver. In this example, the unit address is set to "0."

To avoid problems or malfunction, do not duplicate an address on the same communication line.

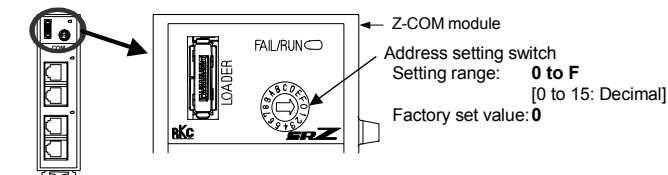

Address setting for PLC communication

Up to four Z-COM modules can be connected to a PLC communication port. Therefore the unit address uses the four Z-COM modules as a group. For Z-COM modules which are multi-duplex connected to the same PLC communication port, use successive numbers assigned to any one of four groups shown in the following table as their addresses.

Always set the unit address of each group including 0, 4, 8 or C. 0, 4, 8 or C becomes the master for communication transfer.

When the PLC and SRZ unit are connected 1-to-1, use the factory set value "0."

Group	Address setting switch	Group	Address setting switch
Group 1	0 (Master)	Group 3	8 (Master)
	1		9
	2		A
	3		B
Group 2	4 (Master)	Group 4	C (Master)
	5		D
	6		E
	7		F

Address setting for loader communication

When loader communication is performed, the host computer and SRZ unit communicate on a one-to-one basis, and the unit address is fixed at "0." Even when an address setting switch is set to other than 0, communication is performed with unit address 0.

3.2 Protocol Selections and Communication Speed Setting

Use the DIP switch on the right side of the Z-COM module to select communication speed, data bit configuration and protocol. Because PLC communication is performed in this example, configure communication 2 (COM. PORT 3, COM. PORT 4).

The data change become valid the power of the Z-COM module is turned on again or when control is switched from STOP to RUN.

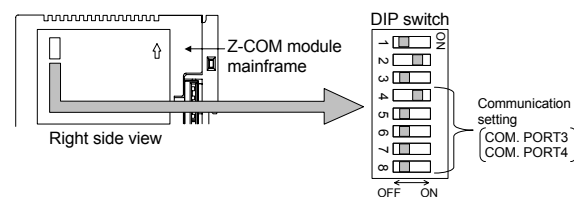

Contents of the DIP switch

Communication 1 (COM. PORT1 and COM. PORT2) setting

Use switches No. 1, No. 2, and No. 3 to set the communication speed, communication protocol and data bit configuration for Communication 1.

1	2	Communication speed
OFF	OFF	4800 bps
ON	OFF	9600 bps
OFF	ON	19200 bps (Factory set value)
ON	ON	38400 bps

3	Communication protocol and Data bit configuration
OFF	Host communication (RKC communication) Data 8-bit, without parity, Stop 1-bit (Factory set value *)
ON	Host communication (Modbus) Data 8-bit, without parity, Stop 1-bit

* Factory set values when the communication protocol is not specified at the order.

Communication 2 (COM. PORT3 and COM. PORT4) setting

Use switches No. 4, No. 5, No. 6, and No. 7 to set the communication speed, communication protocol and data bit configuration for Communication 2.

4	Communication speed
OFF	9600 bps
ON	19200 bps (Factory set value)

5	6	7	Communication protocol and Data bit configuration
OFF	OFF	OFF	Host communication (RKC communication) Data 8-bit, without parity, Stop 1-bit (Factory set value *)
ON	OFF	OFF	Host communication (Modbus) Data 8-bit, without parity, Stop 1-bit
OFF	ON	OFF	PLC communication MITSUBISHI MELSEC series special protocol AnA/AnUCPU common command (QR/QW) Data 7-bit, without parity, Stop 1-bit
ON	ON	OFF	PLC communication OMRON SYSMAC series special protocol C mode command (RD/WD) Data 7-bit, Even parity, Stop 2-bit
OFF	OFF	ON	PLC communication MITSUBISHI MELSEC series special protocol ACPU common command (WR/WW) Data 7-bit, without parity, Stop 1-bit

* Factory set values when the communication protocol is not specified at the order.

Settings of communication speed, communication protocol and data bit configuration can be set even by the loader communication or host communication. For the communication data, see Communication setting data of Z-COM module on the next page.

DIP switch setting validity/invalidity

Set switch No.8 to "ON" when performing communication by the communication settings set via host communication or loader communication. When set to "ON," the DIP switch settings are disabled.

8	DIP switch setting validity/invalidity
OFF	Valid (Factory set value)
ON	Invalid (According to the settings in Host communication or Loader communication)

4. COMMUNICATION SETTING OF FUNCTION MODULES

4.1 Address Setting of Z-TIO/Z-DIO Module

Only make the module address setting to make the Z-TIO and Z-DIO module communication settings. The SRZ unit performs internal communication (RS-485) between the Z-COM module and the functional module (Z-TIO, Z-DIO), so the communication protocol, communication speed and data bit configuration do not need to be set. A module address is set for each function module type. In this example, the unit address is set to the address shown below.

To avoid problems or malfunction, do not duplicate an address in a function module of the same type on the same communication line.

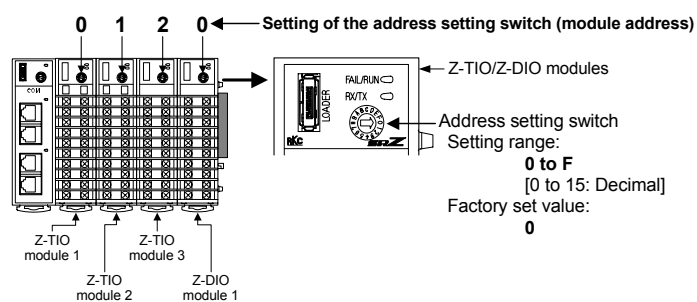

4.2 For the SRZ Unit's Temperature Control Channel

Setting the Z-TIO module address determines the temperature control channel number used for communication. To each Z-TIO module address, the relevant temperature control channel is assigned. Each temperature control channel number can be calculated from the following equation.

$$\text{Temperature control channel number of communication} = [\text{Module address setting}^a] \times [\text{Maximum channel number of the functional module}^b] + [\text{Channel number in a module}]$$

^aWhen the setting is A to F, it is a decimal number.

^bFor the Z-TIO module, it is calculated by "4."

Example: When 3 Z-TIO modules (4-channel type) are joined

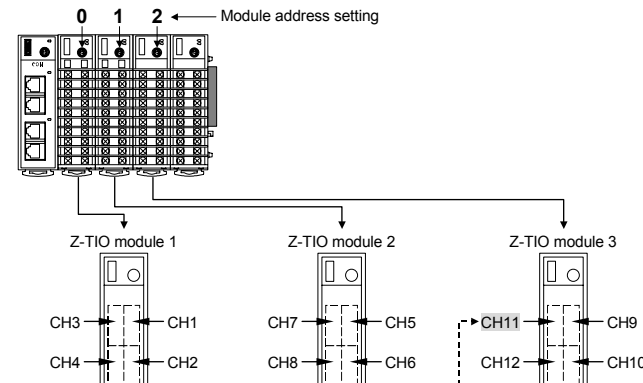

Z-TIO module 3: The temperature control channel number used for communication of channel 3 - $2 \times 4 + 3 = 11$

4.3 Digital Input/Output Channel of Z-DIO Module

Setting the Z-DIO module address determines the digital input/output channel number of SRZ unit. To each Z-DIO module address, the relevant digital input/output channel is assigned. Each digital input/output channel can be calculated from the following equation.

$$\text{Digital input/output channel number} = [\text{Module address setting}^a] \times [\text{Maximum channel number of the functional module}^b] + [\text{Input (or output) channel number in a module}]$$

^aWhen the setting is A to F, it is a decimal number.

^bFor the Z-DIO module, it is calculated by "8."

Example: When 2 Z-DIO modules are joined

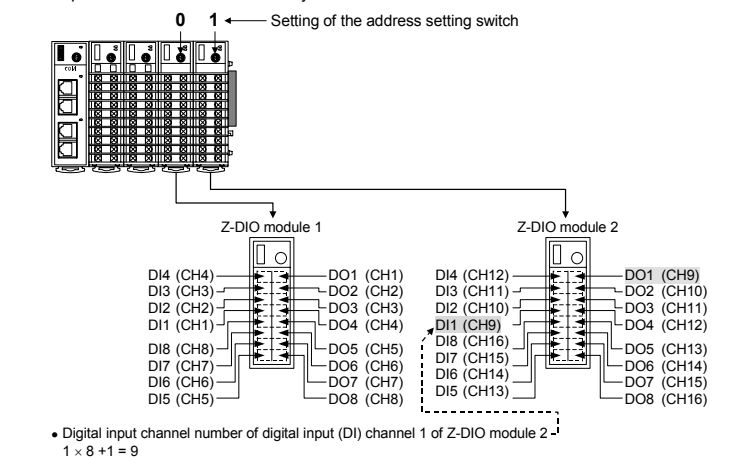

Digital input channel number of digital input (DI) channel 1 of Z-DIO module 2 - $1 \times 8 + 1 = 9$

5. PLC COMMUNICATION ENVIRONMENT SETTING

The PLC communication environmental (system data) settings must be made to perform PLC communication. The system data settings are made by the loader communication (System data settings can also be made in the host communication).

The system data contains setting items (see the setting item table of next page) and monitor items. The monitor items require space (corresponding to 8 words) in the PLC register.

For the monitor items, see Z-COM PLC Communication Data List (IMS01T15-E□).

5.1 Preparation of USB Communication Converter

To perform loader communication, our converter and a communication cable are required.

- USB communication converter COM-K (With USB cable) *
- Loader communication cable W-BV-01 [option]

* To use the loader communication, USB driver for COM-K must be installed on the personal computer. The USB driver for COM-K can be downloaded from our website:
 URL: <http://www.rkcinst.com/>

5.2 Preparation of Communication Program

A communication program must be created on the customer's side to use loader communication. Refer to the RKC communication protocol to create a communication program.

For the RKC communication protocol, see Z-COM Host Communication Instruction Manual (IMS01T23-E□).

5.3 Setting of Loader Communication

Set the communication settings of the host computer to the same settings as the Z-COM module. When loader communication is used, the communication speed, communication protocol, and data bit configuration of the Z-COM module are fixed.

(There is no need to configure the communication settings of the Z-COM module.)

Unit address: 0
 Communication speed: 38400 bps
 Data bit configuration: Data 8-bit, Without parity, Stop 1-bit

5.4 Connection for Loader Communication

Connect SRZ unit to the personal computer. When the personal computer has a USB connector, connect the USB communication converter between the personal computer and the Z-COM module.

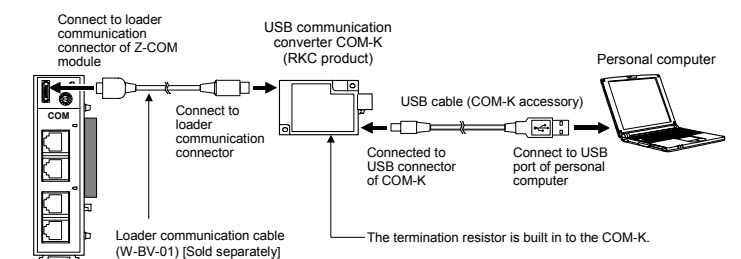

5.5 Setting of System Data (setting items)

- Turn on the power of the SRZ unit. (PLC power is off.)
- On the personal computer, set the communication data of PLC communication environment indicated below.

Setting item table RW: Read/Write

Name	RKC Identifier	Modbus register address		Digits	Attribute	Data range and Number of data	Factory set value
		HEX	DEC				
Station number	QV	8008	32776	7	RW	0 to 31	0
PC number ¹	QW	8009	32777	7	RW	0 to 255	255
Register type ²	QZ	800A	32778	7	RW	MITSUBISHI MELSEC series 0: D register 1: R register 2: W register 3: ZR register 4 to 29: Unused OMRON SYSMAC series 0: DM register (Data memory) 1 to 9: Unused 10 to 22: EM register (Extended data memory) [Specify the bank No.] Set the bank No.+10. 23 to 28: Unused 29: EM register (Extended data memory) [Specify the current bank]	0
Register start number ^{2,3} (High-order 4 bit)	QS	800B	32779	7	RW	0 to 15: QnA compatible 3C frame	0
Register start number ² (Low-order 16 bit)	QX	800C	32780	7	RW	0 to 9999: A compatible, 1C frame, ACPU common command (WR/WW), OMRON SYSMAC series 0 to 65535: A compatible, 1C frame, AnA/AnUCPU common command (QR/QW), QnA compatible 3C frame	1000
System data address bias ^{4,2}	QQ	800D	32781	7	RW	0 to 9999: A compatible, 1C frame, ACPU common command (WR/WW), OMRON SYSMAC series 0 to 65535: A compatible, 1C frame, AnA/AnUCPU common command (QR/QW), QnA compatible 3C frame	2100
COM module link recognition time ⁴	QT	800E	32782	7	RW	0 to 255 seconds	10
PLC scanning time	VT	800F	32783	7	RW	0 to 3000 ms	255
PLC communication start time	R5	8010	32784	7	RW	1 to 255 seconds	5
Slave mapping method ⁵	RK	8012	32786	7	RW	0: Bias from the address setting switch [Register address + (Remainder of set value of address setting switch)4] × System data address bias] 1: Bias disabled	0

- Setting when connected to Mitsubishi's PLC.
- Usable register ranges and types vary depending on used CPU types. For register ranges and types that can actually be used, see the PLC instruction manual.
- Only enabled when the ZR register is selected.
- Use the factory set value when the PLC and SRZ unit are connected 1-to-1.
- Use the factory set value.

- Turn the SRZ unit's power OFF and ON again. When the power is turned ON, the changed system data values are enabled.

Communication setting data of Z-COM module

Z-COM settings of communication speed, communication protocol and data bit configuration can be set even by the loader communication or host communication.

Set switch No.8 to "ON" when performing communication by the communication settings set via host communication or loader communication. When set to "ON," the DIP switch settings are disabled.

If you changed the communication setting data, the data change become valid the power of the Z-COM module is turned on again or when control is switched from STOP to RUN.

RW: Read/Write

Name	RKC Identifier	Modbus register address		Digits	Attribute	Data range and Number of data	Factory set value
		HEX	DEC				
Communication 1 protocol	VK	8000	32768	1	RW	0: RKC communication 1: Modbus	0
Communication 1 communication speed	VL	8001	32769	1	RW	0: 4800 bps 2: 19200 bps 1: 9600 bps 3: 38400 bps	2
Communication 1 data bit configuration	VM	8002	32770	7	RW	Modbus: 0 to 2 RKC communication: 0 to 5 See table 1 (Data bit configuration).	0
Communication 1 interval time	VN	8003	32771	7	RW	0 to 250 ms	10

RW: Read/Write

Name	RKC Identifier	Modbus register address		Digits	Attribute	Data range and Number of data	Factory set value
		HEX	DEC				
Communication 2 protocol	VP	8004	32772	1	RW	0: RKC communication 1: Modbus 2: MITSUBISHI MELSEC series special protocol AnA/AnUCPU common command (QR/QW) 3: OMRON SYSMAC series special protocol 4: MITSUBISHI MELSEC series special protocol ACPU common command (WR/WW)	0
Communication 2 communication speed	VU	8005	32773	1	RW	0: 4800 bps 2: 19200 bps 1: 9600 bps 3: 38400 bps	2
Communication 2 data bit configuration	VW	8006	32774	7	RW	Modbus: 0 to 2 RKC communication: 0 to 5 See table 1 (Data bit configuration).	0
Communication 2 interval time	VX	8007	32775	7	RW	0 to 250 ms	10

Table 1: Data bit configuration

Set value	Data bit	Parity bit	Stop bit	Modbus	RKC communication	PLC communication
0	8	Without	1	Can be set	Can be set	Can be set
1	8	Even	1			
2	8	Odd	1			
3	7	Without	1			
4	7	Even	1	Cannot be set	Cannot be set	Can be set
5	7	Odd	1			
6	8	Without	2			
7	8	Even	2			
8	8	Odd	2			
9	7	Without	2			
10	7	Even	2			
11	7	Odd	2			

Data range: Modbus: 0 to 2 RKC communication: 0 to 5 PLC communication: 0 to 11

6. PLC COMMUNICATION SETTING

Set the communication items of PLC side.

The setting item varies depending the PLC. The details of the setting procedure for the PLC, see the instruction manual for the PLC being used.

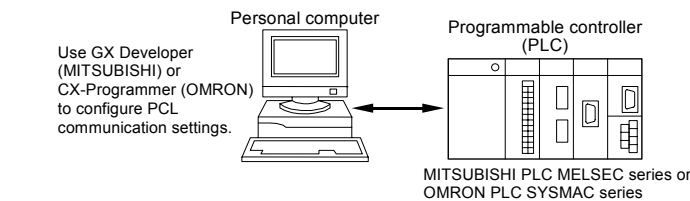

MITSUBISHI PLC MELSEC series

Recommend setting example

Item	Description
Protocol	Type 4 protocol mode
Station number	00
Computer link/multi-drop selection	Computer link
Communication rate	Set the same as Z-COM
Operation setting	Independent
Data bit	7
Parity bit	Without
Stop bit	1
Sum check code	Provided
Writing during RUN	Allowed
Setting modification	Allowed
Termination resistor	Connect the termination resistor attached to the PLC

OMRON SYSMAC series

Recommend setting example

Item	Description
Serial communication mode	High-order link
Unit number (Model No.)	0
Start bit	1
Data bit	7
Stop bit	2
Parity bit	Even
Transmission speed	Set the same as Z-COM
I/O port selection	RS-422A
Synchronization selection	Internal synchronization
CTS selection	0 V (always ON)
5 V supply	OFF
Termination resistor	Termination resistor is inserted

7. PLC COMMUNICATION DATA TRANSFER

The data transmitted between the PLC and the SRZ unit is compiled in the PLC communication data map. In the PLC communication data map the communication data is classified into system data (monitor items), request commands, monitor groups, and setting groups.

For the PLC communication data map, see the **Z-COM PLC Communication Data List (IMS01T15-ED)**.

7.1 Data Transfer Type

Data transfer between PLC and SRZ unit are executed by request command. For the request command, both "setting request bit" and "monitor request bit" are available.

Setting request bit (PLC → SRZ)

This command requests that the SRZ unit read the communication data of the setting group on the PLC side.

[Processing]

- Just when "1" is set to the setting request bit, the SRZ unit starts reading the data from the PLC side.
- All data of the setting communication group is transferred from PLC to the SRZ unit.
- After data transmission is completed, the setting request bit becomes "0."

Monitor request bit (PLC ← SRZ)

This command requests that the SRZ unit write the communication data of the setting group on the PLC side.

[Processing]

- Just when "1" is set to the monitor request bit, the SRZ unit starts writing the data to the PLC side.
- All data of the setting communication group is transferred from SRZ unit to the PLC.
- After data transmission is completed, the monitor request bit becomes "0."

Monitor group

The monitor group communication data is always transferred as monitor data between the PLC and the SRZ unit regardless of the request command setting.

7.2 Data Transfer Procedures

Change each set value of SRZ unit from the PLC after the initial settings are made. If each set value of SRZ unit is changed from the PLC without setting the initial values, it is re-written to "0" with each set value of the PLC at that time set to "0."

Initial setting

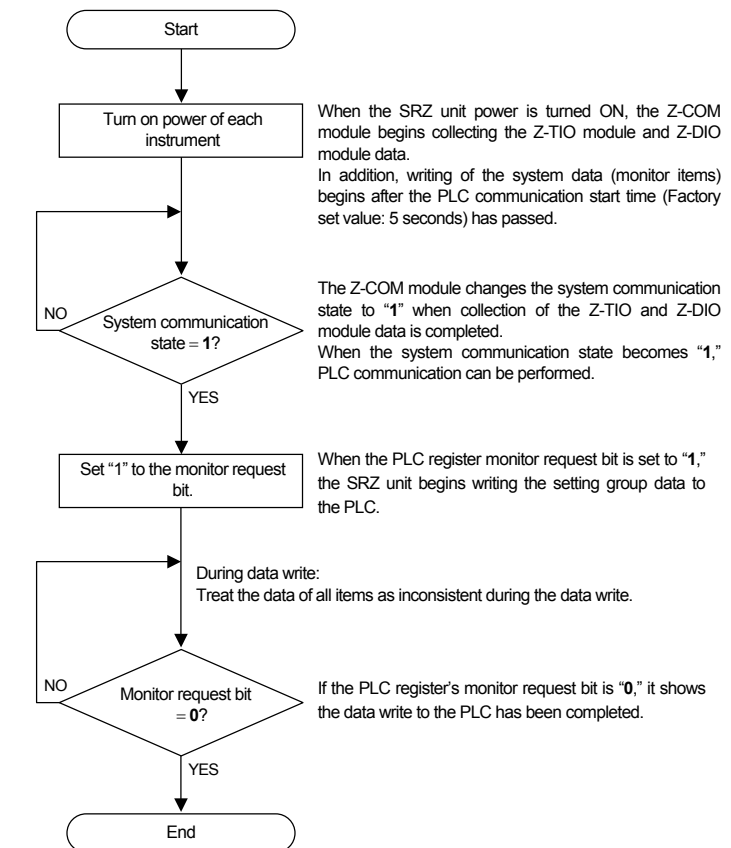

Data setting

When the setting group communication data is transferred from PLC to the SRZ unit.

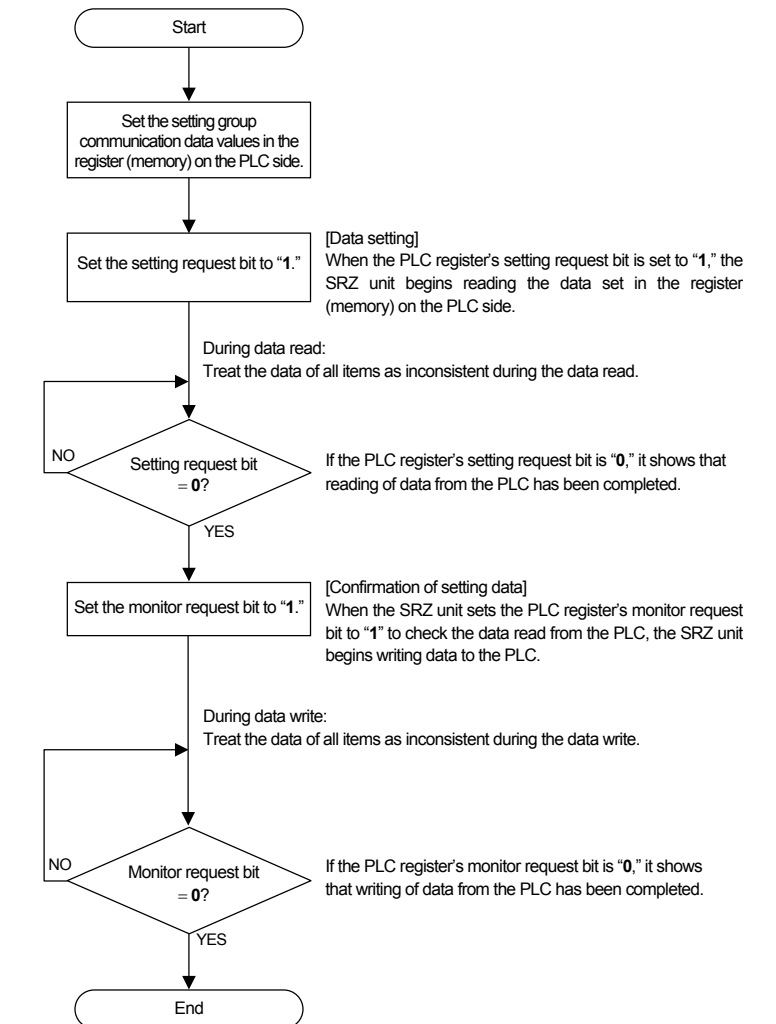

Data processing precautions

The data type is treated as binary data with a sign and without a decimal point. For this reason, carefully express and set the data. (Excluding the bit data)

Modbus is a registered trademark of Schneider Electric. The name of each programmable controller (PLC) means the products of each manufacturer. Company names and product names used in this manual are the trademarks or registered trademarks of the respective companies.