

Thank you for purchasing this RKC product. In order to achieve maximum performance and ensure proper operation of your new instrument, carefully read all the instructions in this manual. Please place this manual in a convenient location for easy reference.

1. OUTLINE

Using the setting examples below, this section explains the configuration when two Z-TIO-C or Z-TIO-D temperature control modules (supporting PLC communication) are connected to a MITSUBISHI MELSEC Series programmable controller (PLC). The PLC communication environmental settings are required to communicate with the PLC. The PLC communication environmental settings are set by the host communication or loader communication, so the host computer and Z-TIO-C or Z-TIO-D module must be connected. (This manual is the explanation by the loader communication.)

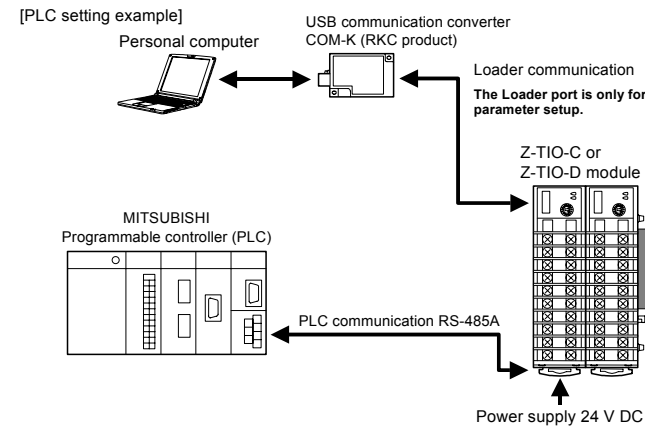

For the host communication, the installation, the detail handling procedures and various function settings, please read if necessary the following separate manuals.

- Z-TIO Instruction Manual [for PLC Communication] (IMS01T10-ED): Enclosed with Z-TIO
- Z-TIO PLC Communication Quick Instruction Manual [Part 2: Operation] (IMS01T12-ED): Enclosed with Z-TIO
- SRZ Instruction Manual [For PLC communication] (IMS01T13-ED): Separate (Download or sold separately)
- SRZ Instruction Manual (IMS01T04-ED): Separate (Download or sold separately)

The above manuals can be downloaded from our website:
URL: http://www.rkcinst.com/english/manual_load.htm

2. HANDLING PROCEDURES

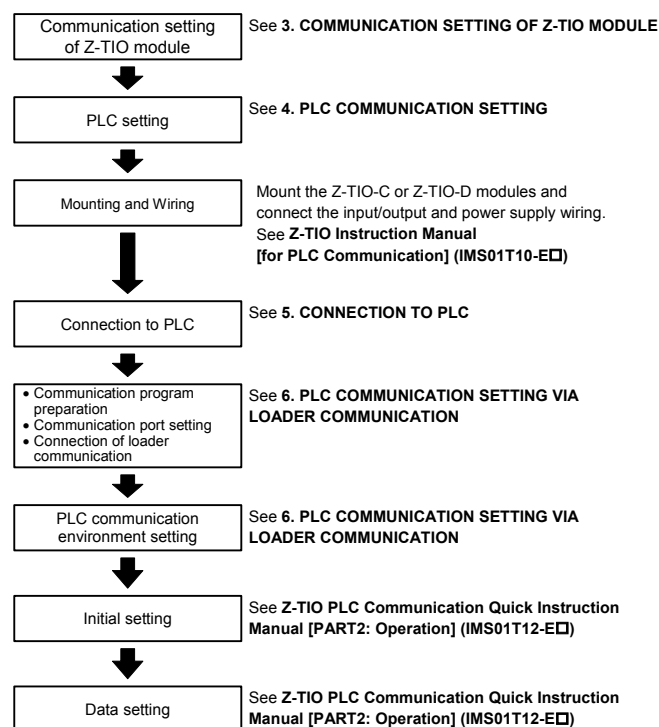

3. COMMUNICATION SETTING OF Z-TIO MODULE

Set communication setting before mounting and wiring of the Z-TIO module.

CAUTION

Do not separate the module mainframe from the base with the power turned on. If so, instrument failure may result.

3.1 Module Address Setting

Set an address for the Z-TIO-C or Z-TIO-D module using a small blade screwdriver.

- When one module is used, set the module address to 0.
- When multiple modules are used, be sure to set one of the modules to module address 0. The module with module address 0 will be the master module.

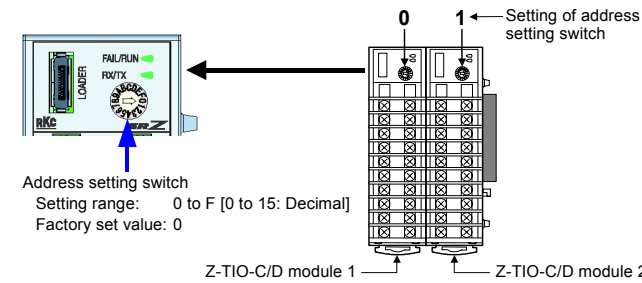

- To avoid problems or malfunction, do not duplicate an address on the same communication line.
- For Modbus, the value obtained by adding "1" to the set address corresponds to the address used for the actual program.

3.2 Protocol Selections and Communication Speed Setting

Use the DIP switch on the right side of module to select communication speed, data bit configuration and protocol. The data changes become valid when the power is turned on again or when changed to RUN/STOP.

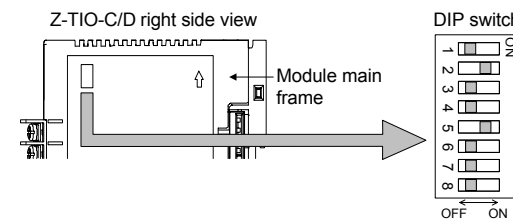

(The above figure is for the terminal type. However, the switch positions are the same for the connector type.)

- Switch No. 8 must be always OFF. Do not set to ON.
- When two or more Z-TIO-C or Z-TIO-D modules are connected on the same communication line, the DIP switch settings of all modules must be the same.

For communication settings when connected to a different functional module, see the **SRZ Instruction Manual [For PLC communication] (IMS01T13-ED)**.

Set the DIP switch settings to the same values as the connected PLC.

1	2	Communication speed
OFF	OFF	4800 bps
ON	OFF	9600 bps
OFF	ON	19200 bps
ON	ON	38400 bps

Factory set value: 19200 bps

3	4	5	Data bit configuration
OFF	OFF	OFF	Data 7-bit, without parity, Stop 1-bit *
OFF	ON	OFF	Data 7-bit, Even parity, Stop 1-bit *
ON	ON	OFF	Data 7-bit, Odd parity, Stop 1-bit *
OFF	OFF	ON	Data 8-bit, without parity, Stop 1-bit
OFF	ON	ON	Data 8-bit, Even parity, Stop 1-bit
ON	ON	ON	Data 8-bit, Odd parity, Stop 1-bit

Factory set value: Data 8-bit, without parity, Stop 1-bit

* When the Modbus communication protocol is selected, this setting becomes invalid.

6	7	Communication protocol
OFF	OFF	RKC communication
ON	OFF	Modbus
OFF	ON	MITSUBISHI MELSEC series special protocol (type 4) A compatible, 1C frame, AnA/AnU CPU common command (QR/QW) QnA compatible, 3C frame, command (0401/1401) ZR register only (AnA/AnU/QnA/Q series)
ON	ON	MITSUBISHI MELSEC series special protocol (type 4) A compatible, 1C frame, ACPU common command (WR/WW) (A series, FX2N, FX2NC series, FX3U/FX3UC series)

Factory set value: Factory set value varies depending on the instrument specification.

4. PLC COMMUNICATION SETTING

Sets the communication items of PLC side. (Recommend setting example)

The setting item varies depending the PLC. The details of the setting procedure for the PLC, see the instruction manual for the PLC being used.

Setting example

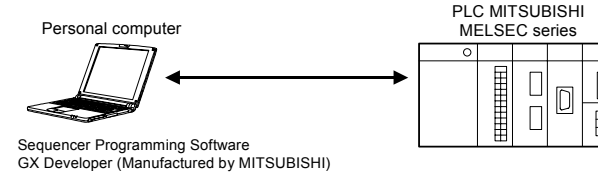

Sequencer Programming Software
GX Developer (Manufactured by MITSUBISHI)

Item	Description
Protocol	Type 4 protocol mode
Station number	00
Computer link/multi-drop selection	Computer link
Communication rate	Set the same as Z-TIO-C or Z-TIO-D
Operation setting	Independent
Data bit	8
Parity bit	Without
Stop bit	1
Sum check code	Provided
Writing during RUN	Allowed
Setting modification	Allowed
Termination resistor	Connect the termination resistor attached to the PLC

5. CONNECTION TO PLC



WARNING
To prevent electric shock or instrument failure, turn off the power before connecting or disconnecting the instrument and peripheral equipment.

Connect a termination resistor between the communication terminals (No.3 and No. 4) of the module at the end of the communication line from the host computer or PLC.

The communication cable must be provided by the customer.

Terminal configuration and wiring example

The Z-TIO-C/D module has RS-485 communication terminals for RKC communication, Modbus/RTU communication and PLC communication protocol. Communication terminals are on the base side.

Communication terminals (RS-485)

Terminal No.	Signal name	Symbol
3	Send data/Receive data	T/R (A)
4	Send data/Receive data	T/R (B)
5	Signal ground	SG

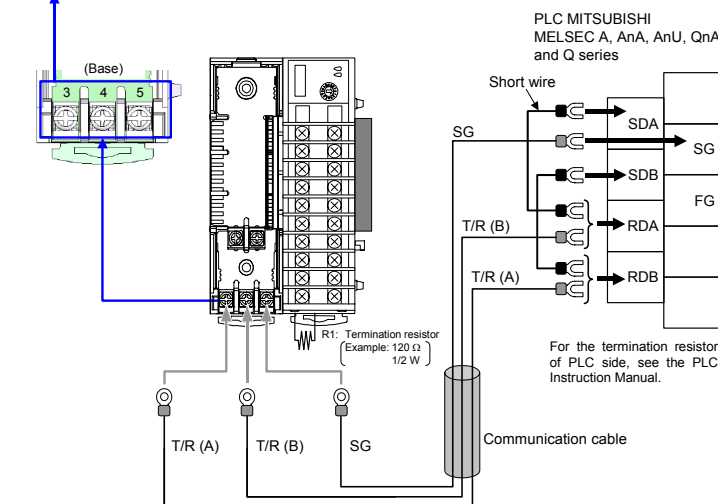

For the termination resistor of PLC side, see the PLC Instruction Manual.

When preparing a cable of connecting the MITSUBISHI MELSEC series to our Z-TIO-C/D module, cross each pair of wires the A and B terminal positions on their terminal boards are not symmetrical.

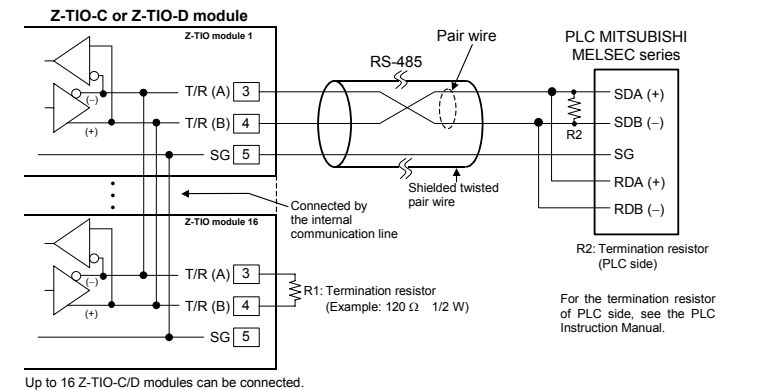

Up to 16 Z-TIO-C/D modules can be connected.

6. PLC COMMUNICATION ENVIRONMENT SETTING VIA LOADER COMMUNICATION

This section explains how to configure the PLC communication environment settings by loader communication. To perform loader communication, a communication program must be created.

6.1 Preparation of USB Communication Converter

To perform loader communication, our converter and a communication cable are required.

- USB communication converter COM-K (With USB cable)
- Loader communication cable W-BV-01 [option]

6.2 Preparation of Communication Program

Refer to the RKC communication protocol or the Modbus communication protocol to create a communication program. (However, the loader communication cannot be used when Modbus protocol is selected.)

For RKC communication or Modbus communication protocol, see **SRZ Instruction Manual (IMS01T04-ED)**.

6.3 Setting of Loader Communication

For loader communication, set the communication port of the computer to the following values. There are no loader communication settings on the Z-TIO-C/D module side.



Communication setting of the personal computer side

Communication speed	38400 bps
Start bit	1
Data bit	8
Parity bit	Without parity
Stop bit	1

Above setting data is fixed.

6.4 Connection of Loader Communication

Connect a USB communication converter COM-K between the personal computer and the Z-TIO-C or Z-TIO-D module.

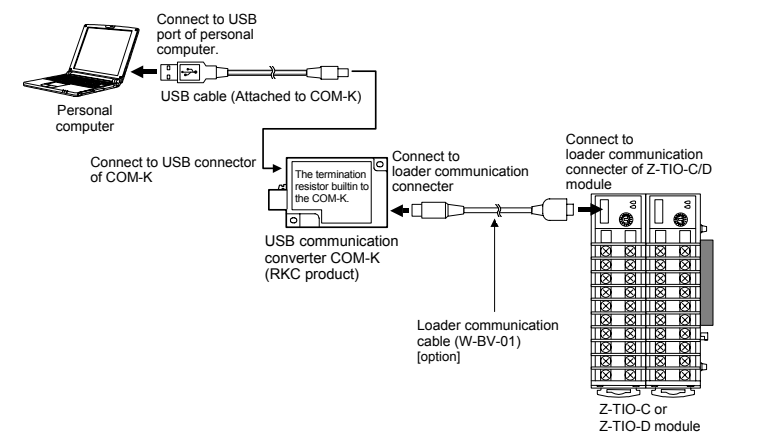

When using the loader communication, the address of all SRZ modules is fixed at 0. The setting of the address setting switch is disregarded.

6.5 Setting of PLC Communication Environment

The PLC communication environmental settings must be made to perform PLC communication. The system data settings are made by the loader communication.

- Turn on the power of the Z-TIO-C or Z-TIO-D module. (PLC power is off.)
- On the personal computer, set the communication data of the PLC communication environment indicated below.
- When the settings for the communication data of the PLC communication environment are completed, turn the power of the Z-TIO-C/D module off, and then turn it on again. When the power is turned ON, the changed system data values are enabled.

Set the communication data for each module. After completing the communication settings of the first module, connect the loader communication cable to the next module and set the PLC communication environment.

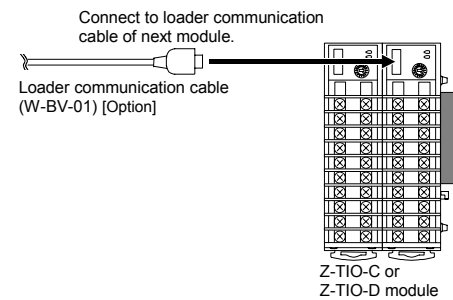

Communication data list (PLC communication environment)

Name	RKC Identifier	Modbus register address		Digits	Attribute	Data range	Factory set value
		HEX	DEC				
Station number	QV	0164	356	7	R/W	0 to 31 Set the PLC station number. Set it to the same number as the PLC.	0
PC number	QW	0165	357	7	R/W	0 to 255 Set the PLC PC number. Set it to the same number as the PLC. Set all Z-TIO-C/D modules to the same values.	255
Register type *	QZ	0166	358	7	R/W	0: D register 1: R register 2: W register 3: ZR register Method of specifying consecutive numbers when 32767 of R register is exceeded. When the ZR register is selected, QnA compatible 3C frame communication is used. Set the register types used in PLC communication.	0
Register start number (High-order 4-bit) *	QS	0167	359	7	R/W	0 to 15 Set the start number of the register of system data used in PLC communication. Set this if the register address 65535 is exceeded in the ZR register.	0
Register start number (Low-order 16-bit) *	QX	0168	360	7	R/W	0 to 9999 A compatible, 1C frame, ACPU common command (WR/WW) 0 to 65535 A compatible 1C frame AnA/AnUCPU common command (QR/QW), QnA compatible 3C frame Set the start number of the register of system data used in PLC communication. System data is required to perform PLC communication. The system data occupies ten PLC registers.	1000
Monitor item register bias *	R3	0169	361	7	R/W	10 to 9999 A compatible, 1C frame, ACPU common command (WR/WW) 0 to 65535 A compatible 1C frame AnA/AnUCPU common command (QR/QW), QnA compatible 3C frame Set the start number of the register of monitor group communication data. A bias is applied to the register start number. The factory set value for the register bias is 10, and thus the register start number of the monitor group is D01010. Equation for calculating: Register start number of monitor group = Register start number + Monitor item register bias	10

Name	RKC Identifier	Modbus register address		Digits	Attribute	Data range	Factory set value
		HEX	DEC				
Setting item register bias *	R4	016A	362	7	R/W	0, 10 to 9999 A compatible, 1C frame, ACPU common command (WR/WW) 0, 10 to 65535 A compatible 1C frame AnA/AnUCPU common command (QR/QW), QnA compatible 3C frame Set the start number of the register of setting group communication data. When set to 0 to 9 In the monitor group, the register start number of the setting group is set after the communication data of the last address. When set to 10 or more A bias is applied to the register start number. If set to 10 or greater, take care that overlapping of the communication data of the monitor group and the register address does not occur. Equation for calculating: Register start number of setting group = Register start number + Setting item register bias	0
Monitor item selection	R6	016C	364	7	R/W	0 to 65535 Select the communication data of monitor group. The selected communication data only performs PLC communication. Convert binary to decimal and configure the setting. (See Table 1)	33535
Setting item selection	R7	016D : 0170	365 : 368	7	R/W	0 to 65535 Select the communication data of setting group. The selected communication data only performs PLC communication. Convert binary to decimal and configure the setting. (See Table 2)	Setting group 1: 62427 Setting group 2: 15583 Setting group 3: 512 Setting group 4: 512
Z-TIO module link recognition time	QT	0171	369	7	R/W	0 to 255 seconds When connecting two or more Z-TIO-C/D module, set the time required until a module after the second module is recognized. Set this item to the master module (address 0).	5
PLC scanning time	VT	0172	370	7	R/W	0 to 3000 ms Set the time of waiting for a response from the PLC. Usually, no factory set values are necessary to be changed.	255
PLC communication start time	R5	0173	371	7	R/W	1 to 255 seconds Time until communication with the PLC starts is set after the power is turned on.	5
Slave register bias *	R8	0175	373	7	R/W	0 to 65535 When connecting two or more Z-TIO-C/D module, a bias is set for the register addresses of each module so that no address duplication occurs. Set bias enable/disable with the address setting switch. When set the address setting switch to 0: Bias disabled When set the address setting switch to other than 0: Bias enabled Equation for calculating: Slave register start number = Register start number + (Address setting switch) × Slave register bias	150
Interval time	ZX	035B	859	7	R/W	0 to 250 ms On some PLC models, the interval time must be set or the PLC will not be able to respond. If communication does not take place correctly on an older MELSEC A Series model, set the interval time to 30 ms or more. Interval time is the engineering setting data. When the Z-TIO module of setting data is stopped, write is possible.	10

* Usable register ranges and types vary depending on used CPU types. For register ranges and types that can actually be used, see the PLC instruction manual.

Table 1: Monitor item selection (Communication data of monitor group)

Communication data of monitor group is assigned as a bit image in binary numbers. Set decimal-converted values.

Bit image: 0000000000000000 0: Unused
bit 15 bit 0 1: Used

The selected communication data is justified upward in the PLC register.

Bit	Communication data (Monitor item)	Number of data	Factory set value	
			Binary	Decimal
0	Measured value (PV)	4	1	33535
1	Comprehensive event state	4	1	
2	Operation mode state monitor	4	1	
3	Error code	4*	1	
4	Manipulated output value (MV) monitor [heat-side] *	4	1	
5	Manipulated output value (MV) monitor [cool-side] *	4	1	
6	Current transformer (CT) input value monitor	4	1	
7	Set value (SV) monitor	4	1	
8	Remote setting (RS) input value monitor	4	0	
9	Output state monitor	4*	1	
10	Memory area soak time monitor	4	0	
11	Integrated operating time monitor	4*	0	
12	Holding peak value ambient temperature monitor	4	0	
13	Backup memory state monitor	4*	0	
14	Logic output monitor	4*	0	
15	Memory area number monitor	4	1	

* When heat/cool control or position proportioning control is performed, there will be communication data (indicated by * in the name column) for which the CH2 and CH4 will be invalid. [Read is possible (0 is shown), but the result of Write is disregarded.]
* Occupies four PLC registers, however, the actual number of data items is 1 (data units are modules), and thus only the data of CH1 is effective.

Table 2: Setting item selection (Communication data of Setting group)

Communication data of setting group is assigned as a bit image in binary numbers. Set decimal-converted values in the setting items of setting group 1 to setting group 4.

Bit image: 0000000000000000 0: Unused
bit 15 bit 0 1: Used

The selected communication data is justified upward in the PLC register.

Setting group 1

Bit	Item number	Number of data (Setting item)	Number of data	Factory set value	
				Binary	Decimal
0	1	PID/AT transfer	4	1	62427
1	2	Auto/Manual transfer	4	1	
2	3	Remote/Local transfer	4	0	
3	4	RUN/STOP transfer	4*	1	
4	5	Memory area transfer	4	1	
5	6	Interlock release	4	0	
6	7	Event 1 set value (EV1) *	4	1	
7	8	Event 2 set value (EV2) *	4	1	
8	9	Event 3 set value (EV3) *	4	1	
9	10	Event 4 set value (EV4) *	4	1	
10	11	Control loop break alarm (LBA) time *	4	0	
11	12	LBA deadband *	4	0	
12	13	Set value (SV) *	4	1	
13	14	Proportional band [heat-side] * *	4	1	
14	15	Integral time [heat-side] * *	4	1	
15	16	Derivative time [heat-side] * *	4	1	

* When heat/cool control or position proportioning control is performed, there will be communication data (indicated by * in the name column) for which the CH2 and CH4 will be invalid. [Read is possible (0 is shown), but the result of Write is disregarded.]
* Occupies four PLC registers, however, the actual number of data items is 1 (data units are modules), and thus only the data of CH1 is effective.
* Parameters which can be used in multi-memory area function

Setting group 2

Bit	Item number	Number of data (Setting item)	Number of data	Factory set value	
				Binary	Decimal
0	17	Control response parameter * *	4	1	15583
1	18	Proportional band [cool-side] * *	4	1	
2	19	Integral time [cool-side] * *	4	1	
3	20	Derivative time [cool-side] * *	4	1	
4	21	Overlap/Deadband * *	4	1	
5	22	Manual reset *	4	0	
6	23	Setting change rate limiter (up) *	4	1	
7	24	Setting change rate limiter (down) *	4	1	
8	25	Area soak time *	4	0	
9	26	Link area number *	4	0	
10	27	Heater break alarm (HBA) set value	4	1	
11	28	Heater break determination point	4	1	
12	29	Heater melting determination point	4	1	
13	30	PV bias	4	1	
14	31	PV digital filter	4	0	
15	32	PV ratio	4	0	

* When heat/cool control or position proportioning control is performed, there will be communication data (indicated by * in the name column) for which the CH2 and CH4 will be invalid. [Read is possible (0 is shown), but the result of Write is disregarded.]
* Parameters which can be used in multi-memory area function

Setting group 3

Bit	Item number	Number of data (Setting item)	Number of data	Factory set value	
				Binary	Decimal
0	33	PV low input cut-off	4	0	512
1	34	RS bias	4	0	
2	35	RS digital filter	4	0	
3	36	RS ratio	4	0	
4	37	Output distribution selection	4	0	
5	38	Output distribution bias	4	0	
6	39	Output distribution ratio	4	0	
7	40	Proportional cycle time	4	0	
8	41	Minimum ON/OFF time of proportioning cycle	4	0	
9	42	Manual manipulated output value *	4	1	
10	43	Area soak time stop function	4	0	
11	44	EDS mode (for disturbance 1)	4	0	
12	45	EDS mode (for disturbance 2)	4	0	
13	46	EDS value 1 (for disturbance 1)	4	0	
14	47	EDS value 1 (for disturbance 2)	4	0	
15	48	EDS value 2 (for disturbance 1)	4	0	

* When heat/cool control or position proportioning control is performed, there will be communication data (indicated by * in the name column) for which the CH2 and CH4 will be invalid. [Read is possible (0 is shown), but the result of Write is disregarded.]

Setting group 4

Bit	Item number	Number of data (Setting item)	Number of data	Factory set value	
				Binary	Decimal
0	49	EDS value 2 (for disturbance 2)	4	0	512
1	50	EDS transfer time (for disturbance 1)	4	0	
2	51	EDS transfer time (for disturbance 2)	4	0	
3	52	EDS action time (for disturbance 1)	4	0	
4	53	EDS action time (for disturbance 2)	4	0	
5	54	EDS action wait time (for disturbance 1)	4	0	
6	55	EDS action wait time (for disturbance 2)	4	0	
7	56	EDS value learning times	4	0	
8	57	EDS start signal	4	0	
9	58	Operation mode	4	1	
10	59	Startup tuning (ST)	4	0	
11	60	Automatic temperature rise learning	4	0	
12	61	Communication switch for logic	4*	0	
13	62	Unused	4	0	
14	63	Unused	4	0	
15	64	Unused	4	0	

* Occupies four PLC registers, however, the actual number of data items is 1 (data units are modules), and thus only the data of CH1 is effective.

Modbus is a registered trademark of Schneider Electric. The name of each programmable controller (PLC) means the products of each manufacturer. Company names and product names used in this manual are the trademarks or registered trademarks of the respective companies.