

# Module Type Controller SRV

Temperature Control Module for DeviceNet

# V-TIO-J/V-TIO-K

## Instruction Manual

IMS01P10-E1

Thank you for purchasing this RKC product. In order to achieve maximum performance and ensure proper operation of your new instrument, carefully read all the instructions in this manual. Please place this manual in a convenient location for easy reference.

### SYMBOLS

**WARNING** : This mark indicates precautions that must be taken if there is danger of electric shock, fire, etc., which could result in loss of life or injury.

**CAUTION** : This mark indicates that if these precautions and operating procedures are not taken, damage to the instrument may result.



: This mark indicates that all precautions should be taken for safe usage.



: This mark indicates important information on installation, handling and operating procedures.



: This mark indicates supplemental information on installation, handling and operating procedures.



: This mark indicates where additional information may be located.



### WARNING

- An external protection device must be installed if failure of this instrument could result in damage to the instrument, equipment or injury to personnel.
- All wiring must be completed before power is turned on to prevent electric shock, fire or damage to instrument and equipment.
- This instrument must be used in accordance with the specifications to prevent fire or damage to instrument and equipment.
- This instrument is not intended for use in locations subject to flammable or explosive gases.
- Do not touch high-voltage connections such as power supply terminals, etc. to avoid electric shock.
- RKC is not responsible if this instrument is repaired, modified or disassembled by other than factory-approved personnel. Malfunction can occur and warranty is void under these conditions.

### CAUTION

- This is a Class A instrument. In a domestic environment, this instrument may cause radio interference, in which case the user may be required to take adequate measures.

- This instrument is protected from electric shock by reinforced insulation. Provide reinforced insulation between the wire for the input signal and the wires for instrument power supply, source of power and loads.
- Be sure to provide an appropriate surge control circuit respectively for the following:
  - If input/output or signal lines within the building are longer than 30 meters.
  - If input/output or signal lines leave the building, regardless the length.
- This instrument is designed for installation in an enclosed instrumentation panel. All high-voltage connections such as power supply terminals must be enclosed in the instrumentation panel to avoid electric shock by operating personnel.
- All precautions described in this manual should be taken to avoid damage to the instrument or equipment.
- All wiring must be in accordance with local codes and regulations.
- All wiring must be completed before power is turned on to prevent electric shock, instrument failure, or incorrect action.

The power must be turned off before repairing work for input break and output failure including replacement of sensor, contactor or SSR, and all wiring must be completed before power is turned on again.

- To prevent instrument damage or failure, protect the power line and the input/output lines from high currents with a protection device such as fuse, circuit breaker, etc.
- Prevent metal fragments or lead wire scraps from falling inside instrument case to avoid electric shock, fire or malfunction.
- Tighten each terminal screw to the specified torque found in the manual to avoid electric shock, fire or malfunction.
- For proper operation of this instrument, provide adequate ventilation for heat dispensation.
- Do not connect wires to unused terminals as this will interfere with proper operation of the instrument.
- Turn off the power supply before cleaning the instrument.
- Do not use a volatile solvent such as paint thinner to clean the instrument. Deformation or discoloration will occur. Use a soft, dry cloth to remove stains from the instrument.
- To avoid damage to instrument display, do not rub with an abrasive material or push front panel with a hard object.
- Do not connect modular connectors to telephone line.

### NOTICE

- This manual assumes that the reader has a fundamental knowledge of the principles of electricity, process control, computer technology and communications.
- The figures, diagrams and numeric values used in this manual are only for purpose of illustration.
- RKC is not responsible for any damage or injury that is caused as a result of using this instrument, instrument failure or indirect damage.
- Periodic maintenance is required for safe and proper operation of this instrument. Some components have a limited service life, or characteristics that change over time.
- Every effort has been made to ensure accuracy of all information contained herein. RKC makes no warranty expressed or implied, with respect to the accuracy of the information. The information in this manual is subject to change without prior notice.
- No portion of this document may be reprinted, modified, copied, transmitted, digitized, stored, processed or retrieved through any mechanical, electronic, optical or other means without prior written approval from RKC.

# 1. OUTLINE

The temperature control module for DeviceNet V-TIO-J/V-TIO-K can send and receive data to/from DeviceNet compatible programmable controller (PLC) by the DeviceNet that is a multi-vendor compatible open field network. One V-TIO-J/V-TIO-K module enables temperature control corresponding to two channels. It has power supply and communication terminals in addition to temperature control input and output terminals. All data are set by communication.

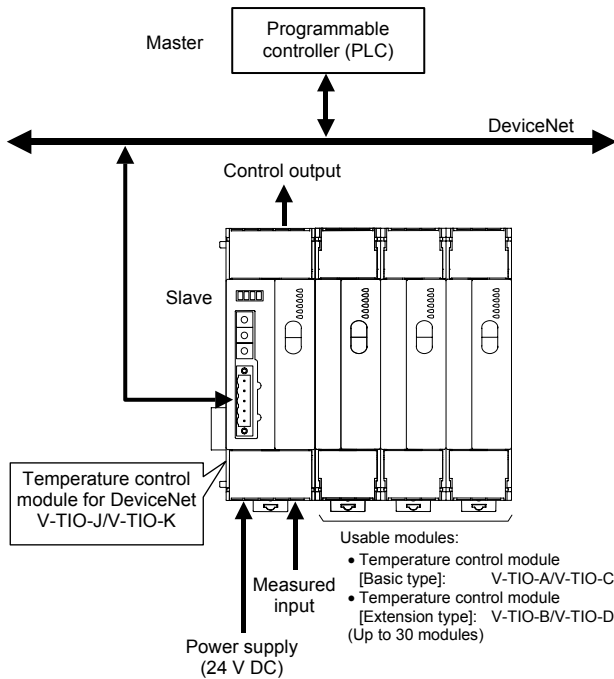

- For details when dividing two or more temperature control modules into some groups and then installed, see the **Module Type Controller SRV DeviceNet Communication Instruction Manual (IMS01P11-E□)**.
- For details, see the **Module Type Controller SRV DeviceNet Communication Instruction Manual (IMS01P11-E□)**.
- For host communication using host communication terminals, see the **Appendix B of Module Type Controller SRV DeviceNet Communication Instruction Manual (IMS01P11-E□)** and the **Module Type Controller SRV Communication Instruction Manual (IMS01P01-E□)**.

# 2. PRODUCT CHECK

Before using this product, check each of the following:

- Model code
- Check that all of the accessories delivered are complete.
- Check that there are no scratch or breakage in external appearance (case, front panel, or terminal, etc).

V-TIO- □ □ □ □ - □ □ \* N N N - N N - □ - □  
 (1) (2) (3) (4) (5) (6) (7)

## (1) Type

- J: Module for DeviceNet, heat control
- K: Module for DeviceNet, heat/cool control

## (2) Control action (Each channel common code)

- [For heat control]
- F: PID action with autotuning (AT) (reverse action)
- D: PID action with autotuning (AT) (direct action)
- [For heat/cool control]
- B: Heat/cool PID action with autotuning (AT) (air cooling)
- W: Heat/cool PID action with autotuning (AT) (water cooling)

## (3) Input range (Each channel common code)

[Thermocouple input]

Type	Code	Range	Code	Range
K	K02	0 to 400 °C	KB9	32 to 752 °F
	K04	0 to 800 °C	KB8	32 to 1472 °F
	K16	-200 to +1372 °C	KB7	-328 to +2501 °F
	K09	0.0 to 400.0 °C	KC2	32.0 to 752.0 °F
	K35	-200.0 to +400.0 °C	KC1	-328.0 to +752.0 °F
J	J02	0 to 400 °C	JC2	32 to 752 °F
	J04	0 to 800 °C	JC1	32 to 1472 °F
	J15	-200 to +1200 °C	JB9	-328 to +2192 °F
	J09	0.0 to 400.0 °C	JC4	32.0 to 752.0 °F
	J27	-200.0 to +400.0 °C	JC3	-328.0 to +752.0 °F
T	T08	0 to 400 °C	TB9	32 to 752 °F
	T09	0 to 200 °C	TC1	32 to 392 °F
	T16	-200 to +400 °C	TB8	-328 to +752 °F
	T06	0.0 to 400.0 °C	TC3	32.0 to 752.0 °F
	T19	-200.0 to +400.0 °C	TC2	-328.0 to +752.0 °F
E	E01	0 to 800 °C	EA8	32 to 1472 °F
	E02	0 to 1000 °C	EA7	32 to 1832 °F
S	S05	0 to 1768 °C	SA6	32 to 3214 °F
R	R06	0 to 1768 °C	RA6	32 to 3214 °F
N	N02	0 to 1300 °C	NA6	32 to 2372 °F
B	B03	0 to 1800 °C	BB1	32 to 3272 °F
PL II	A02	0 to 1390 °C	AA6	32 to 2534 °F
W5Re/ W26Re	W03	0 to 2300 °C	WA9	32 to 4172 °F

[RTD input]

Type	Code	Range	Code	Range
Pt100	D17	0 to 400 °C	DC5	32 to 752 °F
	D33	0 to 850 °C	DC4	32 to 1562 °F
	D16	0.0 to 400.0 °C	DC7	32.0 to 752.0 °F
	D28	-200.0 to +400.0 °C	DC6	-328.0 to +752.0 °F
JPt100	P17	0 to 400 °C	PC5	32 to 752 °F
	P23	0 to 600 °C	PC4	32 to 1112 °F
	P16	0.0 to 400.0 °C	PC7	32.0 to 752.0 °F
	P28	-200.0 to +400.0 °C	PC6	-328.0 to +752.0 °F

[Voltage/current input]

	Code	Type	Code	Type
Voltage	201	0 to 100 mV DC	401	0 to 5 V DC
	501	0 to 10 V DC	601	1 to 5 V DC
Current	701	0 to 20 mA DC	801	4 to 20 mA DC

## (4) Control output (CH1), (5) Control output (CH2)

- M: Relay contact output V: Voltage pulse output 0/12 V DC
- 4: 0 to 5 V DC 5: 0 to 10 V DC 6: 1 to 5 V DC
- 7: 0 to 20 mA DC 8: 4 to 20 mA DC

## (6) CT type (Each channel common code)

- P: CTL-6-P-N (for 0 to 30 A) S: CTL-12-S56-10L-N (for 0 to 100 A)

## (7) DeviceNet connector type

- N: Open-style connector (Unshielded type)
- 1: Micro-style connector (Shield type)

For heat/cool PID control (V-TIO-K), input channel 2 becomes unused.

For heat/cool PID control (V-TIO-K), Control output (CH1) corresponds to the heating output and Control output (CH2) corresponds to the cooling output.

Heater break alarm function can not be used when control output is voltage/current output.

### ■ Accessories

- Floppy disk (EDS file)..... 1
- End Plate..... 2
- Joint connector cover..... 2
- Instruction Manual (IMS01P10-E1)..... 1

If any of the products are missing, damaged, or if your manual is incomplete, please contact RKC sales office or the agent.

### 3. PARTS DESCRIPTION

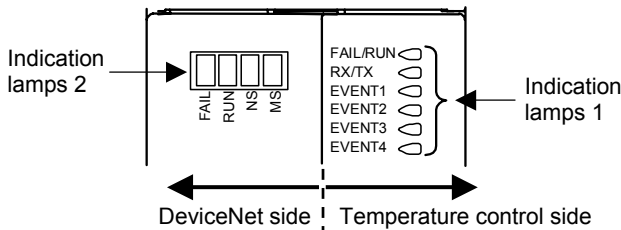
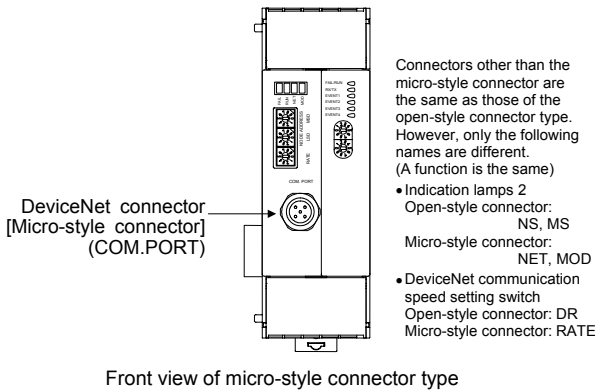
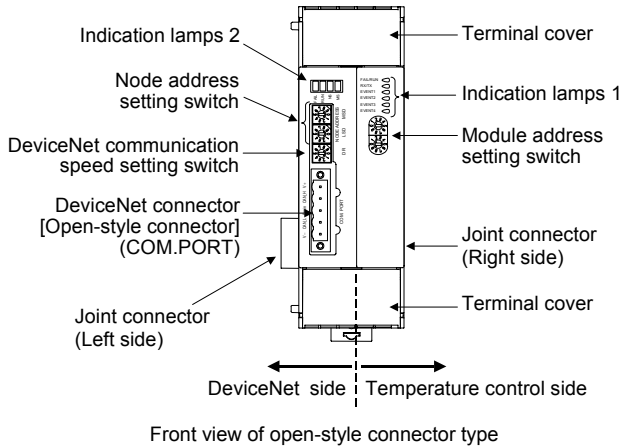

[Indication lamps 1]

- FAIL/RUN (for temperature control)
  - When normally: A green lamp turns on (RUN)
  - When abnormally: A red lamp turns on (FAIL)
- RX/TX (for host communication using host communication terminals)
  - During data send and receive: A green lamp turns on
- EVENT 1 to 4
  - Display various states by setting.
  - ON state: A green lamp turns on
  - Display contents:
    - Event 1 state, Event 2 state, Comprehensive event state, Output state, Control state, Execution segment state, Time signal state

[Indication lamps 2]

- FAIL (for DeviceNet communication)
  - When abnormally: A red lamp turns on
  - Communication environment setting mode by the switch: A red lamp flashes
- RUN (for DeviceNet communication)
  - When normally: A green lamp turns on
  - Memory backup error: A green lamp flashes slowly
  - Module configuration error: A green lamp flashes slowly
  - Communication error: A green lamp flashes slowly
  - Data collection just after the power is turned on: A green lamp flashes rapidly
- NS or NET (Network status)
  - Network is operating normally, but communications have not yet been established: A green lamp flashes

- Network is operating normally (communications established): A green lamp turns on
- I/O connection is timeout: A red lamp flashes
- A fatal communications error has occurred: A red lamp turns on
- Network communications are not possible: A red lamp turns on
- MS or MOD (Module status)
  - When DeviceNet communication is normal: A green lamp turns on
  - Module configuration error: A green lamp flashes
  - Memory backup error: A red lamp turns on

### 4. COMMUNICATION SETTING

Set communication setting before mounting and wiring of SRV.

**CAUTION**

Do not separate the module mainframe from the terminal base with the power turned on. If separated, adjusted data may be destroyed; control be stopped, and no return can be made.

#### 4.1 Address Setting

##### ■ Node address setting

To identify each device connected to the network, it is necessary to set a different address to each device (node). For the DeviceNet, as it is possible to connect up to 64 devices including a master to the network, node address (MAC ID) from 0 to 63 can be set. For this setting, use a small blade screwdriver.

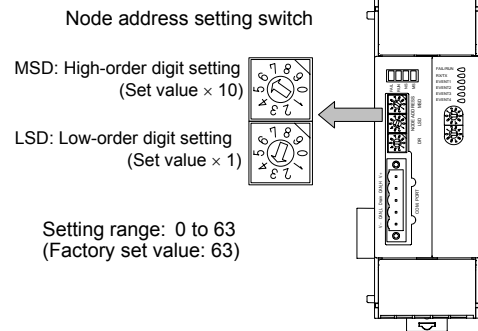

The above figure is open-style connector type. The figure of micro-style connector type is the same as an open-style connector type.

When any number exceeding 64 is set, the node address number becomes "63."

##### ■ Module address setting

Set a module address (temperature control side). For this setting, use a small blade screwdriver.

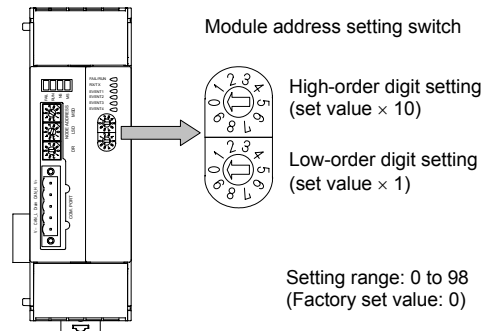

Do not set "99" to a module address of the temperature control side, as the module address of DeviceNet side is fixed in "99." Otherwise, malfunction may result.



Set the module address such that it is different to the other addresses on the same line. Otherwise, problems or malfunction may result.



The previous page figure is open-style connector type. The figure of micro-style connector type is the same as an open-style connector type.

## 4.2 DeviceNet Communication Setting

### ■ Communication speed setting

Set the communication speed of DeviceNet. For this setting, use a small blade screwdriver.

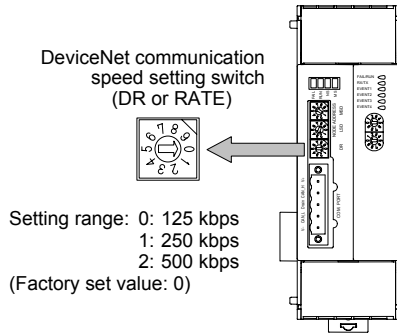

The above figure is open-style connector type. The figure of micro-style connector type is the same as an open-style connector type.



When any number between 3 and 9 is set, the communication speed becomes "500 kbps."

### ■ Number of communication data items when conducting polling I/O communication and host communication protocol setting

With the DIP switch 1 which there is on the left side of module, set the number of communication data items when conducting DeviceNet polling I/O communication, host communication protocol and internal communication mode.

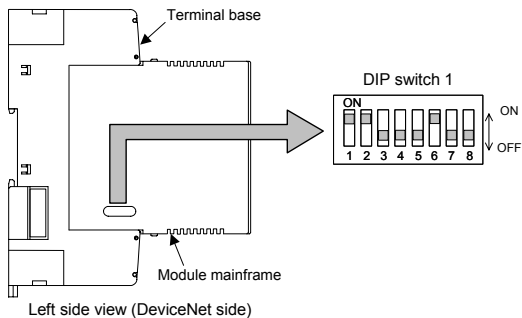

1	2	Host communication (RS-485) speed
OFF	OFF	2400 bps
ON	OFF	9600 bps
OFF	ON	19200 bps
ON	ON	38400 bps

Factory set value: 38400 bps

4	5	Number of communication data items when conducting polling I/O communication
OFF	OFF	8 words
ON	OFF	26 words
OFF	ON	46 words
ON	ON	100 words

Factory set value: 8 words

6	Host communication protocol selection
OFF	RKC communication
ON	Modbus

Factory set value: Modbus

7	Internal communication mode selection
OFF	DeviceNet communication mode
ON	Host communication (RS-485) mode

Factory set value: DeviceNet communication mode



Switch No. 3: OFF fixed (Don't change this one)  
Switch No. 8: OFF fixed (Don't change this one)



Switch No. 1, 2, 6 and 7 are used for the setting related to host communication on the DeviceNet side. When used only for DeviceNet communication, do not change the factory set values.



For the host communication of DeviceNet side, see the Appendix B of Module Type Controller SRV DeviceNet Communication Instruction Manual (IMS01P11-E0).

## 4.3 Host Communication Setting (temperature control side)

With the DIP switch 2 which there is on the right side of module, set the communication speed, data bit configuration, protocol, and termination resistor of internal data bus for host communication of temperature control side.

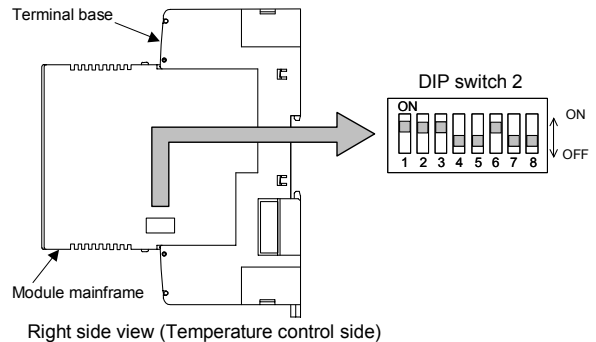

1	2	Host communication (RS-485) speed
OFF	OFF	2400 bps
ON	OFF	9600 bps
OFF	ON	19200 bps
ON	ON	38400 bps

Factory set value: 38400 bps

3	4	5	Data bit configuration
ON	OFF	OFF	Data 8-bit, without parity, Stop 1-bit

Factory set value: Data 8-bit, without parity, Stop 1-bit

6	Host communication protocol selection
OFF	RKC communication
ON	Modbus

Factory set value: Modbus



Switch No. 7: OFF fixed (Don't change this one)  
Switch No. 8: OFF fixed (Don't change this one)



When connecting two or more modules (V-TIO-A, V-TIO-B, V-TIO-C or V-TIO-D) to the module (V-TIO-J or V-TIO-K), match all of the switch No. 1 to 6 settings with the internal settings of the module (V-TIO-J or V-TIO-K).



When no host communication terminals are used, it is not necessary to set the DIP switch 2.



For host communication using host communication terminals, see the Appendix B of Module Type Controller SRV DeviceNet Communication Instruction Manual (IMS01P11-E0) and the Module Type Controller SRV Communication Instruction Manual (IMS01P01-E0).

## 5. MOUNTING



### WARNING

To prevent electric shock or instrument failure, always turn off the power before mounting or removing the instrument.

### 5.1 Mounting Cautions

- (1) This instrument is intended to be used under the following environmental conditions. **(IEC61010-1)**  
[OVERVOLTAGE CATEGORY II, POLLUTION DEGREE 2]
- (2) Use this instrument within the following ambient temperature and ambient humidity.
  - Allowable ambient temperature: -10 to +50 °C
  - Allowable ambient humidity: 5 to 95 % RH  
(Absolute humidity: MAX.W.C 29 g/m<sup>3</sup> dry air at 101.3 kPa)
- (3) Avoid the following when selecting the mounting location.
  - Rapid changes in ambient temperature, which may cause condensation.
  - Corrosive or inflammable gases.
  - Direct vibration or shock to the mainframe.
  - Water, oil, chemicals, vapor or steam splashes.
  - Excessive dust, salt or iron particles.
  - Excessive induction noise, static electricity, magnetic fields or noise.
  - Direct air flow from an air conditioner.
  - Exposure to direct sunlight.
  - Excessive heat accumulation.
- (4) Mounting consideration
  - Install the module 200 mm away from the main power line.
  - Ensure at least 50 mm space on top and bottom of the control unit for maintenance and environmental reasons.

### 5.2 Dimensions

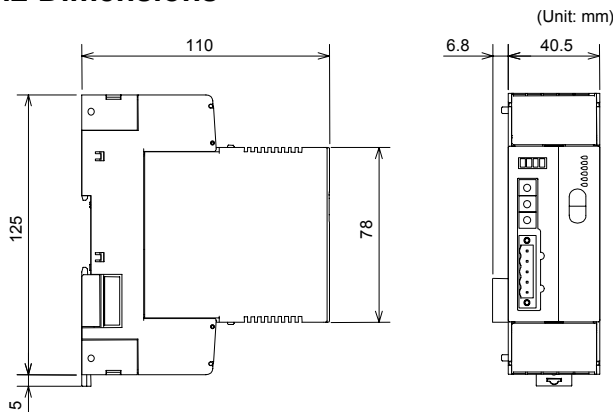

The above figure is open-style connector type. The figure of micro-style connector type is the same as an open-style connector type.

#### ● Depth in connector mounting

Conduct installation in consideration of the sizes of the connector and cable when connector-connected.

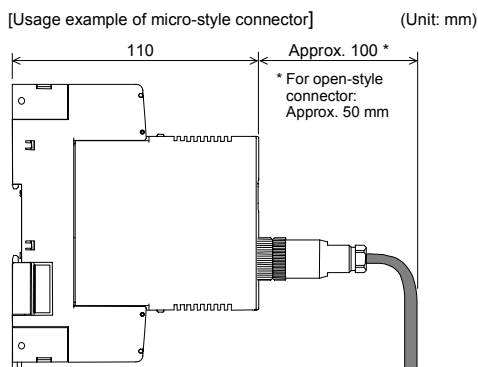

### 5.3 DIN rail Mounting

#### ■ Mounting procedures

1. Pull down the mounting bracket at the bottom of the module (A). Attach the hooks on the top of the module to the DIN rail and push the lower section into place on the DIN rail (B).

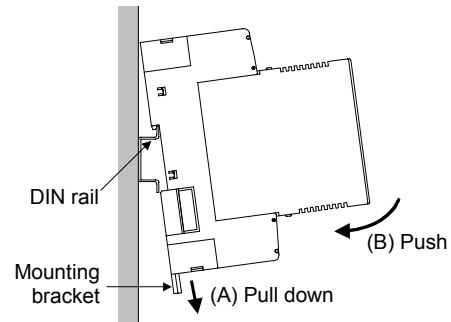

2. Slide the mounting bracket up to secure the module to the DIN rail.

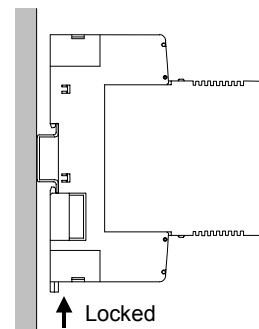

#### ■ End Plate mounting

Hold tight both ends of the modules joined together with the end plates and then fix the end plates with screws. Even if only one V-TIO-J/V-TIO-K module is used, also hold tight both ends of the module with the end plates.

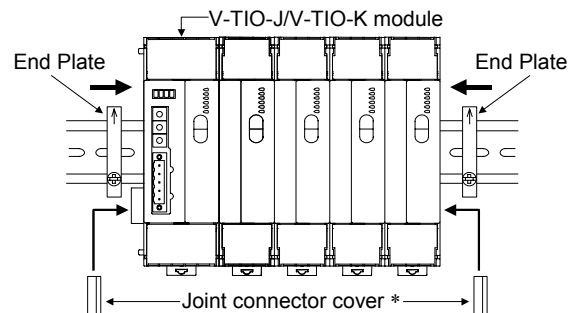

\* For the conservation of the contact of connector, install a joint connector cover in module of both ends.

#### ■ Removing procedures

Pull down a mounting bracket with a blade screwdriver (A). Lift the module from bottom, and take it off (B).

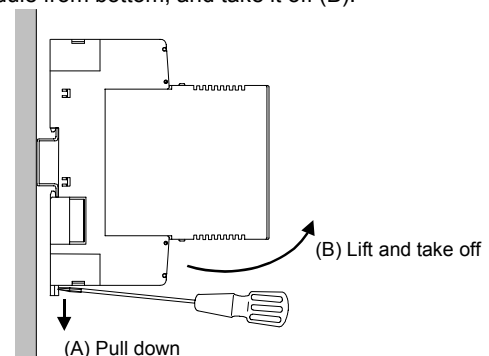

## 5.4 Panel Mounting

### ■ Mounting procedures

1. Pull down the mounting bracket (A) until locked and that a mounting hole appears.
2. Prepare one mounting bracket per module (B) sold separately (KSRX-55) and then insert it in the rear of the terminal board at top of the module until locked but a mounting hole does not disappear.
3. Mount each module directly on the panel with screws which are inserted in the mounting holes of the top and bottom mounting brackets.

Recommended tightening torque: 0.3 N·m (3 kgf·cm)



The customer needs to provide the M3 size screws. Select the screw length that matches the mounting panel.

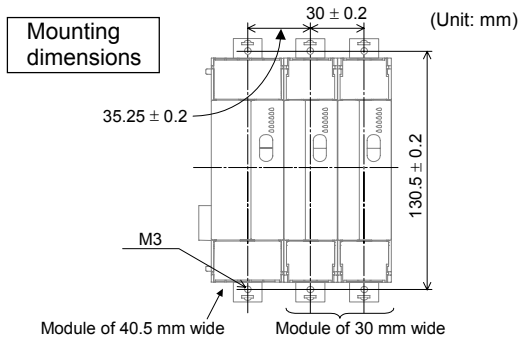
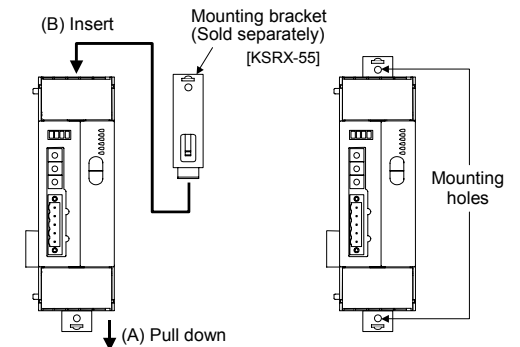

## 5.5 Jointing Each Module

Up to 30 modules (V-TIO-A, V-TIO-B, V-TIO-C or /V-TIO-D) can be connected to one module (V-TIO-J or V-TIO-K). Joint these modules according to the following procedure.

### ■ Jointing procedures

1. Mount the modules on the DIN rail and then joint these modules together with the joint connector while sliding the relevant module.
2. Lift each of the joint tabs located at the top and bottom of the module and then insert it in the slot of the adjacent module to fix these two modules.



For panel mounting, first joint each module and then mount it on the panel.

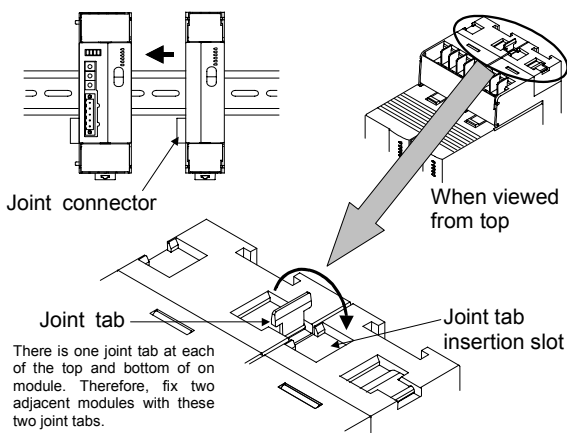

There is one joint tab at each of the top and bottom of on module. Therefore, fix two adjacent modules with these two joint tabs.

## 6. WIRING



### WARNING

To prevent electric shock or instrument failure, do not turn on the power until all the wiring is completed.

### 6.1 Wiring Cautions

- For thermocouple input, use the appropriate compensation wire.
- For RTD input, use low resistance lead wire with no difference in resistance between the three lead wires.
- To avoid noise induction, keep input signal wire away from instrument power line, load lines and power lines of other electric equipment.
- If there is electrical noise in the vicinity of the instrument that could affect operation, use a noise filter.
  - Shorten the distance between the twisted power supply wire pitches to achieve the most effective noise reduction.
  - Always install the noise filter on a grounded panel. Minimize the wiring distance between the noise filter output and the instrument power supply terminals to achieve the most effective noise reduction.
  - Do not connect fuses or switches to the noise filter output wiring as this will reduce the effectiveness of the noise filter.
- Power supply wiring must be twisted and have a low voltage drop.
- For an instrument with 24 V power supply, supply power from a SELV circuit.

### 6.2 Terminal Configuration

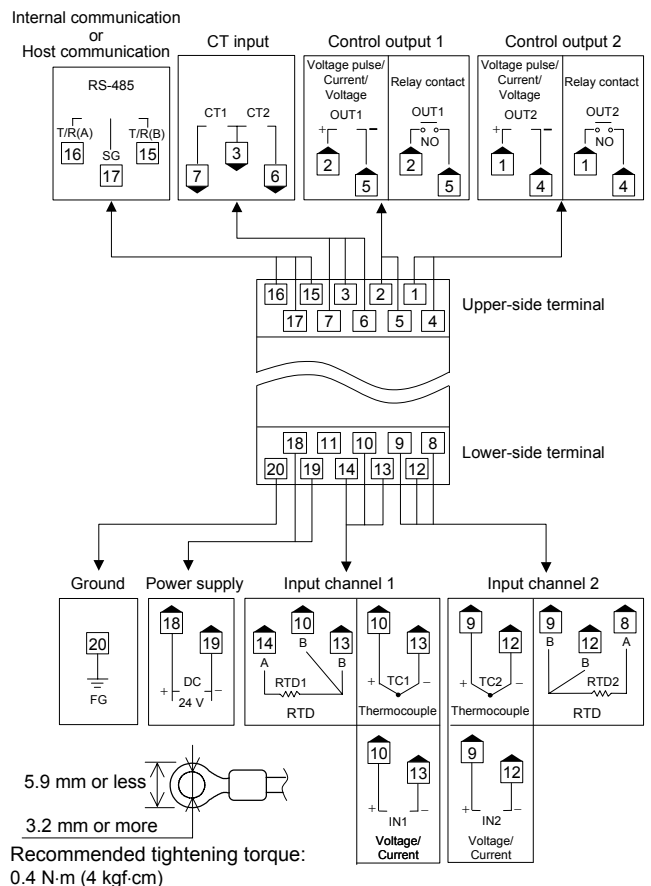

For heat/cool PID control (V-TIO-K), input channel 2 becomes unused.



For heat/cool PID control (V-TIO-K), Control output (CH1) corresponds to the heating output and Control output (CH2) corresponds to the cooling output.



Heater break alarm function can not be used when control output is voltage/current output.



Terminal No. 11 is not used.



Use the solderless terminal appropriate to the screw size (M3).



For cable specifications, connection method and vendor, see the home page of ODVA (Open DeviceNet Vendor Association).

URL: <http://www.odva.org>

## 6.3 Pin Layout of Connector

### ■ Open-style connector

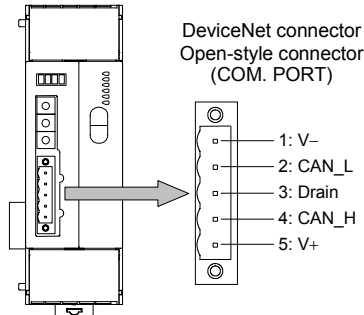

Pin No.	Signal name	Symbol	Cable color
1	Power supply, minus (-)	V-	Black
2	Communication data, low	CAN_L	Blue
3	Shield	Drain	—
4	Communication data, high	CAN_H	White
5	Power supply, plus (+)	V+	Red

- Connection plugs  
SRXDN-01 (Sold separately)  
MSTB2.5/5-STF-5.08AUM (PHOENIX CONTACT, Inc.) or equal

(Multi-drop type (recommended models)  
TMSTBP2.5/5-STF-5.08AUM  
(PHOENIX CONTACT, Inc.)

### ■ Micro-style connector

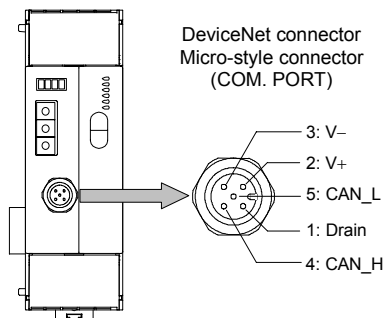

Pin No.	Signal name	Symbol	Cable color
1	Shield	Drain	—
2	Power supply, plus (+)	V+	Red
3	Power supply, minus (-)	V-	Black
4	Communication data, high	CAN_H	White
5	Communication data, low	CAN_L	Blue

- Connection socket  
Recommended models: SACC-M12FS-5CON-PG 9-M  
(PHOENIX CONTACT, Inc.)  
(This socket is a type to use thin cable.)



Use the communication cable (thick cable or thin cable) that matched specification of DeviceNet.  
By thickness of a cable to use and connection method, usable connection connector type is different.

## 7. SPECIFICATIONS

### ■ Inputs

Number of inputs: 2 points  
Isolated between each channel:  
Thermocouple input, Voltage (low) input  
Not isolated between each channel:  
RTD input, Voltage (high) input,  
Current input

Input type:

- Thermocouple: K, J, T, S, R, E, B, N (JIS-C1602-1995)  
PLII (NBS)  
W5Re/W26Re (ASTM-E988-96)
- RTD: Pt100 (JIS-C1604-1997)  
JPt100 (JIS-C1604-1989, Pt100 of  
JIS-C1604-1981)
- Voltage (low): 0 to 100 mV
- Voltage (high): 0 to 5 V, 0 to 10 V, 1 to 5 V
- Current: 0 to 20 mA, 4 to 20 mA  
(Input impedance: 250 Ω)

Sampling cycle: 500 ms

PV bias: -Input span to +Input span

CT input: 2 points

0.0 to 30.0 A (CTL-6P-N) or  
0.0 to 100.0 A (CTL-12-S56-10L-N)

### ■ Outputs

Number of outputs: 2 points  
(Isolated between input and output, and  
between output and power supply)

Output type:

- Relay contact: 250 V AC, 3 A (Resistive load)  
1a contact  
Electrical life: 300,000 times or more  
(Rated load)
- Voltage pulse: 0/12 V DC  
(Load resistance 600 Ω or more)
- Current: 0 to 20 mA DC, 4 to 20 mA DC  
(Load resistance 600 Ω or less)
- Voltage: 0 to 5 V DC, 0 to 10 V DC, 1 to 5 V DC  
(Load resistance 1 kΩ or more)

### ■ Control action

Number of controls: 2 points  
Control method: Brilliant PID control  
Reverse action or direct action is  
selectable (Specify when ordering)  
Heat/cool control is selectable  
(Specify when ordering)  
Additional function: Autotuning function

### ■ Events

Number of events: 2 points/channel  
Event type: Temperature event:  
Deviation high, Deviation low,  
Deviation high/low, Band,  
Process high, Process low  
Heater break alarm,  
Control loop break alarm,  
Burnout, Temperature rise completion

### ■ Heater break alarm (HBA) function

Number of HBA: 2 points  
Setting range: 0.0 to 100.0 A (0.0 A: OFF)  
Additional function: Number of event delay times:  
1 to 255 times

Continued on the next page.

Continued from the previous page.

### ■ Control loop break alarm (LBA) function

Number of LBA: 2 points  
LBA time: 1 to 7200 seconds  
LBA deadband (LBD) setting:  
0 to Input span

### ■ DeviceNet communication

Protocol: DeviceNet  
Connection method: Multi-drop connection,  
T-branch connection  
(Terminating resistor [121Ω, 1/4 W] is  
necessary)  
Communication speed: 125 kbps, 250 kbps, or 500 kbps  
Error control: CRC error, Node address (MAC ID)  
duplication check  
Maximum number of connection nodes:  
64 (including master)

### ■ Host communication (using host communication terminals)

Communication interface: Based on RS-485, EIA standard  
Communication protocol: RKC communication  
(ANSI X3.28 subcategory 2.5, A4)  
or Modbus  
Maximum connections: 32 instruments \* maximum including  
a host computer  
\* As each of the DeviceNet board and  
temperature control board incorporated in the  
V-TIO-J/V-TIO-K module is handled as one unit,  
one V-TIO-J/V-TIO-K module corresponds two  
modules.

### ■ Others

Power supply voltage: 24 V DC  
Power supply voltage range:  
21.6 V DC to 26.4 V DC  
Current consumption: 170 mA max./module  
Allowable ambient temperature:  
-10 to +50 °C  
Allowable ambient humidity:  
5 to 95 %RH  
Absolute humidity:  
MAX.W.C 29 g/m<sup>3</sup> dry air at 101.3 kPa  
Weight: Open-style connector type:  
Approx. 250 g  
Micro-style connector type:  
Approx. 270 g

- DeviceNet is a registered trademark of Open DeviceNet Vender Association, Inc.
- Modbus is a registered trademark of Schneider Electric.
- Company names and product names used in this manual are the trademarks or registered trademarks of the respective companies.
- This product has been self-tested by RKC found to comply with ODVA Conformance Test Software V17.

The first edition: AUG. 2004 [IMQ00]