*CC-Link Communication
Converter*

COM-JC
[For SRZ]

Instruction Manual

- CC-Link is a registered trademark of Mitsubishi Electric Co. Ltd.
- Modbus is a registered trademark of Schneider Electric.
- The name of each programmable controller (PLC) means the products of each manufacturer.
- Company names and product names used in this manual are the trademarks or registered trademarks of the respective companies.

Thank you for purchasing this RKC product. In order to achieve maximum performance and ensure proper operation of your new instrument, carefully read all the instructions in this manual. Please place the manual in a convenient location for easy reference.

SYMBOLS

WARNING : This mark indicates precautions that must be taken if there is danger of electric shock, fire, etc., which could result in loss of life or injury.

CAUTION : This mark indicates that if these precautions and operating procedures are not taken, damage to the instrument may result.



: This mark indicates that all precautions should be taken for safe usage.



: This mark indicates important information on installation, handling and operating procedures.



: This mark indicates supplemental information on installation, handling and operating procedures.



: This mark indicates where additional information may be located.



WARNING

- An external protection device must be installed if failure of this instrument could result in damage to the instrument, equipment or injury to personnel.
- All wiring must be completed before power is turned on to prevent electric shock, fire or damage to instrument and equipment.
- This instrument must be used in accordance with the specifications to prevent fire or damage to instrument and equipment.
- This instrument is not intended for use in locations subject to flammable or explosive gases.
- Do not touch high-voltage connections such as power supply terminals, etc. to avoid electric shock.
- RKC is not responsible if this instrument is repaired, modified or disassembled by other than factory-approved personnel. Malfunction can occur and warranty is void under these conditions.

CAUTION

- This product is intended for use with industrial machines, test and measuring equipment. (It is not designed for use with medical equipment and nuclear energy.)
- This is a Class A instrument. In a domestic environment, this instrument may cause radio interference, in which case the user may be required to take additional measures.
- This instrument is protected from electric shock by reinforced insulation. Provide reinforced insulation between the wire for the input signal and the wires for instrument power supply, source of power and loads.
- Be sure to provide an appropriate surge control circuit respectively for the following:
 - If input/output or signal lines within the building are longer than 30 meters.
 - If input/output or signal lines leave the building, regardless the length.
- This instrument is designed for installation in an enclosed instrumentation panel. All high-voltage connections such as power supply terminals must be enclosed in the instrumentation panel to avoid electric shock by operating personnel.
- All precautions described in this manual should be taken to avoid damage to the instrument or equipment.
- All wiring must be in accordance with local codes and regulations.
- All wiring must be completed before power is turned on to prevent electric shock, instrument failure, or incorrect action.

The power must be turned off before repairing work for input break and output failure including replacement of sensor, contactor or SSR, and all wiring must be completed before power is turned on again.
- To prevent instrument damage or failure, protect the power line and the input/output lines from high currents with a protection device such as fuse, circuit breaker, etc.
- Prevent metal fragments or lead wire scraps from falling inside instrument case to avoid electric shock, fire or malfunction.
- Tighten each terminal screw to the specified torque found in the manual to avoid electric shock, fire or malfunction.
- For proper operation of this instrument, provide adequate ventilation for heat dispensation.
- Do not connect wires to unused terminals as this will interfere with proper operation of the instrument.
- Turn off the power supply before cleaning the instrument.
- Do not use a volatile solvent such as paint thinner to clean the instrument. Deformation or discoloration will occur. Use a soft, dry cloth to remove stains from the instrument.
- To avoid damage to instrument display, do not rub with an abrasive material or push front panel with a hard object.
- Do not connect modular connectors to telephone line.

NOTICE

- This manual assumes that the reader has a fundamental knowledge of the principles of electricity, process control, computer technology and communications.
- The figures, diagrams and numeric values used in this manual are only for purpose of illustration.
- RKC is not responsible for any damage or injury that is caused as a result of using this instrument, instrument failure or indirect damage.
- RKC is not responsible for any damage and/or injury resulting from the use of instruments made by imitating this instrument.
- Periodic maintenance is required for safe and proper operation of this instrument. Some components have a limited service life, or characteristics that change over time.
- Every effort has been made to ensure accuracy of all information contained herein. RKC makes no warranty expressed or implied, with respect to the accuracy of the information. The information in this manual is subject to change without prior notice.
- No portion of this document may be reprinted, modified, copied, transmitted, digitized, stored, processed or retrieved through any mechanical, electronic, optical or other means without prior written approval from RKC.

CONTENTS

	Page
1. OUTLINE	1
1.1 Product Check	2
1.2 Model Code	2
1.3 Parts Description	3
2. HANDLING PROCEDURES.....	4
3. MOUNTING.....	5
3.1 Mounting Cautions.....	5
3.2 Dimensions.....	6
3.3 DIN Rail Mounting	6
3.4 Panel Mounting.....	7
4. WIRING.....	8
4.1 Wiring Cautions	8
4.2 Terminal Configuration	9
4.3 Connection to PLC.....	10
4.4 Connection to Controllers	13
4.5 Installation of Termination Resistor.....	14
5. SETTING.....	16
5.1 Station Number Setting.....	16
5.2 Communication Speed Setting	17
5.3 Number of Occupied Station/Extended Cyclic and Controller Communication Speed Setting	18
5.4 Controller Setting	19
6. CC-Link COMMUNICATION	20
6.1 Communication Between Master Station and COM-JC (Remote Device Station)...	20
6.2 CC-Link Flag Operation	22
6.3 Processing of Numeric Data Values	25
6.4 Module Address and Number of CC-Link Assignment Channels.....	26

	Page
7. COMMUNICATION DATA LIST	29
7.1 Remote Input/Output	29
7.1.1 1 station occupied 1 time	30
7.1.2 4 stations occupied 1 time	32
7.1.3 4 stations occupied 2 times	37
7.1.4 4 stations occupied 4 times	44
7.2 Remote Register	56
7.2.1 1 station occupied 1 time (1 channel assignment)	57
7.2.2 1 station occupied 1 time (2 channels assignment)	58
7.2.3 4 stations occupied 1 time (8 channels assignment)	59
7.2.4 4 stations occupied 1 time (16 channels assignment)	60
7.2.5 4 stations occupied 2 times (16 channels assignment)	61
7.2.6 4 stations occupied 2 times (32 channels assignment)	63
7.2.7 4 stations occupied 4 times (32 channels assignment)	65
7.2.8 4 stations occupied 4 times (64 channels assignment)	69
7.3 Extension Number	73
8. USAGE EXAMPLE	98
8.1 Handling Procedures	98
8.2 System Configuration	99
8.3 Use Instruments Setting	100
8.4 Device Assignments Example	102
8.5 Sample Program	108
9. TROUBLESHOOTING.....	113
10. SPECIFICATIONS	115

1. OUTLINE

This manual describes the communication specifications, mounting, wiring, setting and data instructions for the CC-Link Communication Converter COM-JC.

CC-Link Communication Converter COM-JC (hereafter called COM-JC) is communication converter to connect the RKC module type controller SRZ to a programmable controller (Mitsubishi Electric PLC MELSEC series: hereafter called PLC) for CC-Link.

In addition, COM-JC is connected to CC-Link as the remote device station.

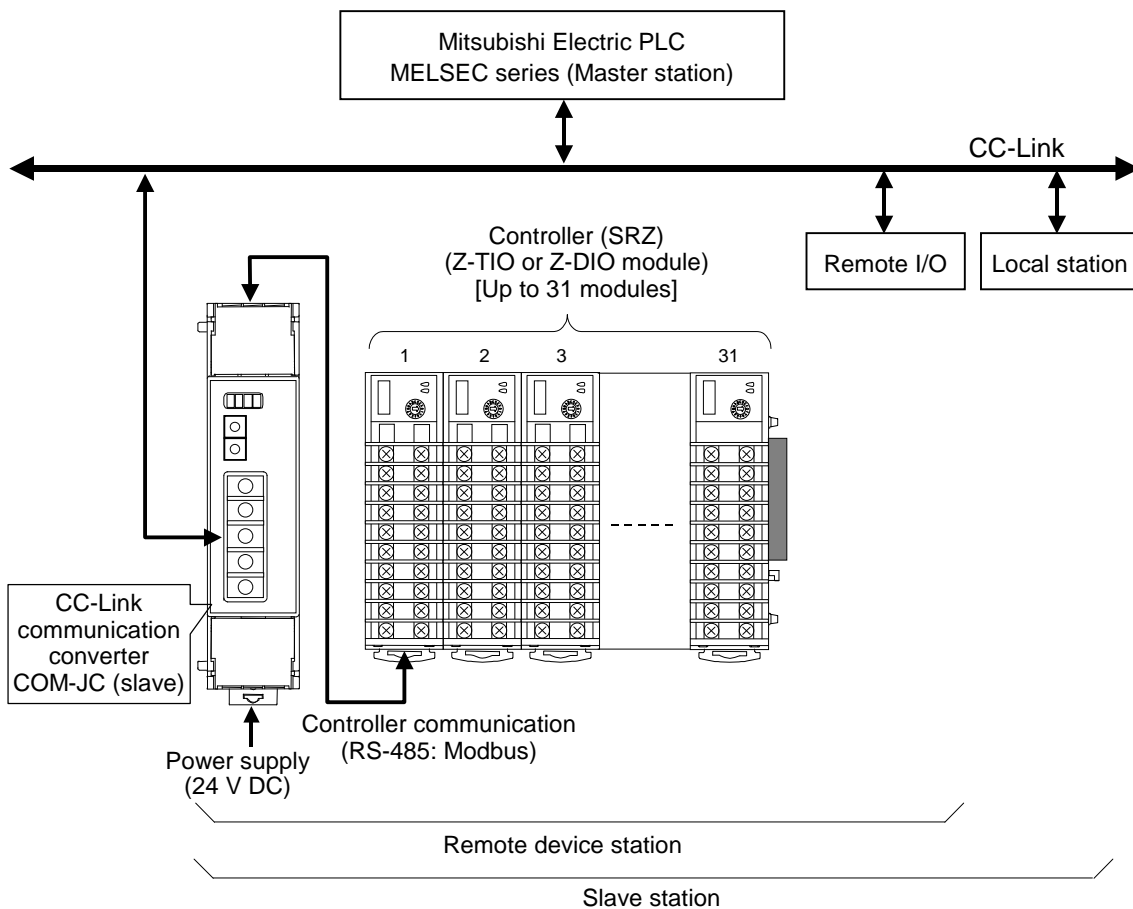

☞ For CC-Link, refer to the website of CC-Link Partner Association.
<http://www.cc-link.org/>

1.1 Product Check

Before using this product, check each of the following.

- Model code
- Check that there are no scratch or breakage in external appearance (case, front panel, terminal, etc).
- Check that all of the accessories delivered are complete. (Refer to below)

Accessories	Q'TY	Remarks
<input type="checkbox"/> COM-JC [For SRZ] Installation Manual (IMR01Y22-E□)	1	Enclosed with instrument
<input type="checkbox"/> COM-JC [For SRZ] Quick Instruction Manual (IMR01Y26-E□)	1	Enclosed with instrument
<input type="checkbox"/> COM-JC [For SRZ] Communication Data List (IMR01Y30-E□)	1	Enclosed with instrument
<input type="checkbox"/> COM-JC [For SRZ] Instruction Manual (IMR01Y34-E3)	1	This manual (sold separately) *

* This manual can be downloaded from the official RKC website:

http://www.rkcinst.com/english/manual_load.htm.



If any of the products are missing, damaged, or if your manual is incomplete, please contact RKC sales office or the agent.

1.2 Model Code

Check whether the delivered product is as specified by referring to the following model code list.
If the product is not identical to the specifications, please contact RKC sales office or the agent.

COM- JC * 02- □
(1) (2)

(1) Corresponding to the RKC controller

02: SRZ

(2) RUN/STOP logic selection

1: 0: RUN
1: STOP
2: 0: STOP
1: RUN

1.3 Parts Description

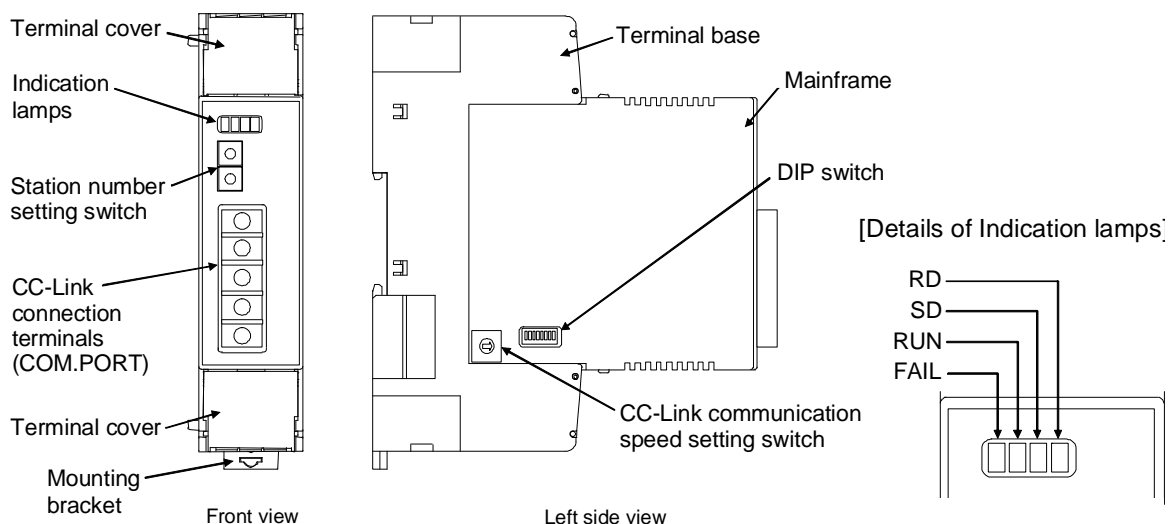

● Indication lamps

FAIL [Red]	<ul style="list-style-type: none"> When instrument abnormally: ON CC-Link setting error: ON CC-Link operation error: Flashes slowly CC-Link setting is changed: Flashes rapidly
RUN [Green]	<ul style="list-style-type: none"> When normally: ON Operation error: Flashes slowly During controller communication initialization: Flashes rapidly
SD [Green]	During CC-Link data send: ON
RD [Green]	During CC-Link data receive: ON

● CC-Link connection terminals

COM. PORT	Terminals for PLC (Master) connection
-----------	---------------------------------------

● Switches

Station number setting switch	Set the station number for CC-Link
CC-Link communication speed setting switch	Set the communication speed for CC-Link
DIP switch	<ul style="list-style-type: none"> Set the number of occupied station/extension cyclic for CC-Link Set the communication speed for controller communication

● Other

Terminal cover	Terminal cover above and below the COM-JC
Mounting bracket	<ul style="list-style-type: none"> Used for the DIN rail mounting When panel mounted, two mounting brackets are required for the upper and lower sides (one required for the upper side: separately sold).
Terminal base	Part of the terminal and base of COM-JC (There is the termination resistor setting switch in the inside of terminal base)
Mainframe	Part of the mainframe of COM-JC

2. HANDLING PROCEDURES

Conduct the setting necessary for performing communication in accordance with the following procedure.

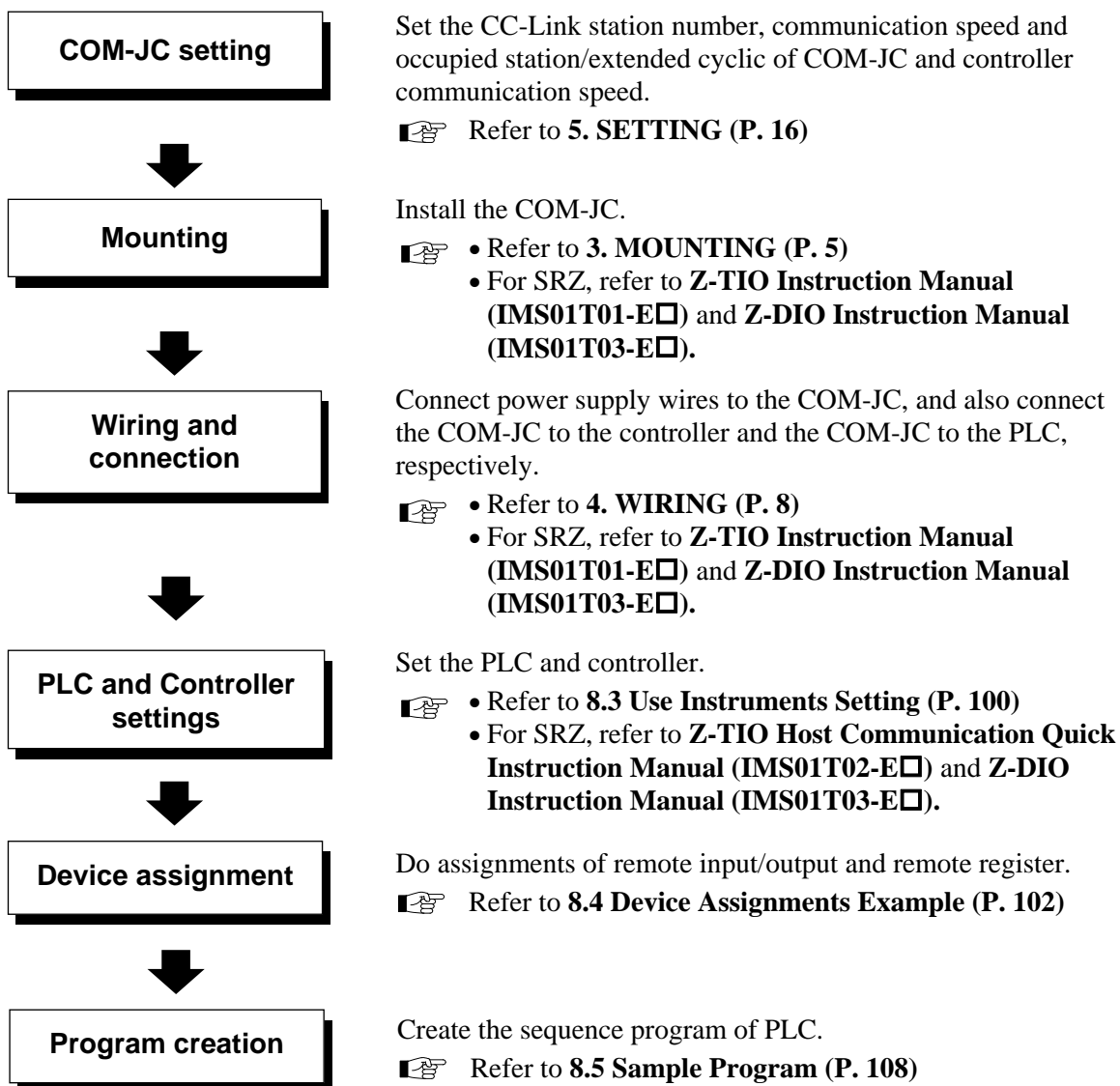

To avoid error at operation start-up, COM-JC must be powered on LAST (after the Controller, PLC, etc.).

3. MOUNTING

This chapter describes installation environment, mounting cautions, dimensions and mounting procedures.



WARNING

To prevent electric shock or instrument failure, always turn off the power before mounting or removing the instrument.

3.1 Mounting Cautions

- (1) This instrument is intended to be used under the following environmental conditions. **(IEC61010-1)**
[OVERVOLTAGE CATEGORY II, POLLUTION DEGREE 2]
- (2) Use this instrument within the following environment conditions.
 - Allowable ambient temperature: -10 to +50 °C
 - Allowable ambient humidity: 5 to 95 %RH
(Absolute humidity: MAX.W.C 29.3 g/m³ dry air at 101.3 kPa)
 - Installation environment conditions: Indoor use
Altitude up to 2000 m
- (3) Avoid the following conditions when selecting the mounting location.
 - Rapid changes in ambient temperature which may cause condensation.
 - Corrosive or inflammable gases.
 - Direct vibration or shock to the mainframe.
 - Water, oil, chemicals, vapor or steam splashes.
 - Excessive dust, salt or iron particles.
 - Excessive induction noise, static electricity, magnetic fields or noise.
 - Direct air flow from an air conditioner.
 - Exposure to direct sunlight.
 - Excessive heat accumulation.
- (4) Take the following points into consideration when mounting this instrument.
 - Ensure at least 50 mm space on top and bottom of the instrument for maintenance and environmental reasons.
 - Do not mount this instrument directly above equipment that generates large amount of heat (heaters, transformers, semi-conductor functional devices, large-wattage resistors).
 - If the ambient temperature rises above 50 °C, cool this instrument with a forced air fan, cooler, or the like. However, do not allow cooled air to blow this instrument directly.
 - In order to improve safety and the immunity to withstand noise, mount this instrument as far away as possible from high voltage equipment, power lines, and rotating machinery.
 - High voltage equipment: Do not mount within the same panel.
 - Power lines: Separate at least 200 mm.
 - Rotating machinery: Separate as far as possible.
- (5) If this instrument is permanently connected to equipment, it is important to include a switch or circuit-breaker into the installation. This should be in close proximity to the equipment and within easy reach of the operator. It should be marked as the disconnecting device for the equipment.

3.2 Dimensions

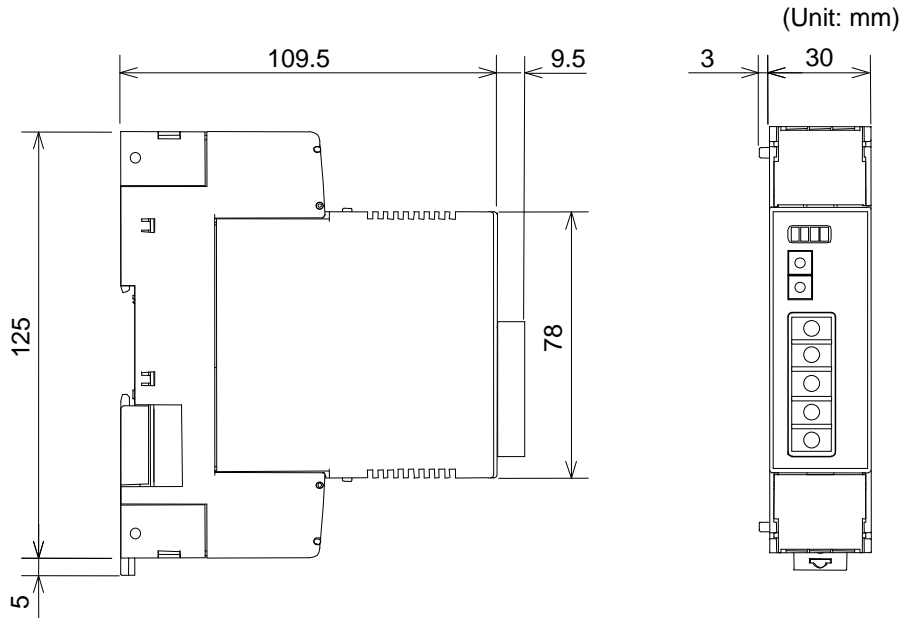

3.3 DIN Rail Mounting

■ Mounting procedures

1. Pull down the mounting bracket at the bottom of the instrument (A). Attach the hooks on the top of the instrument to the DIN rail and push the lower section into place on the DIN rail (B).
2. Slide the mounting bracket up to secure the instrument to the DIN rail (C).

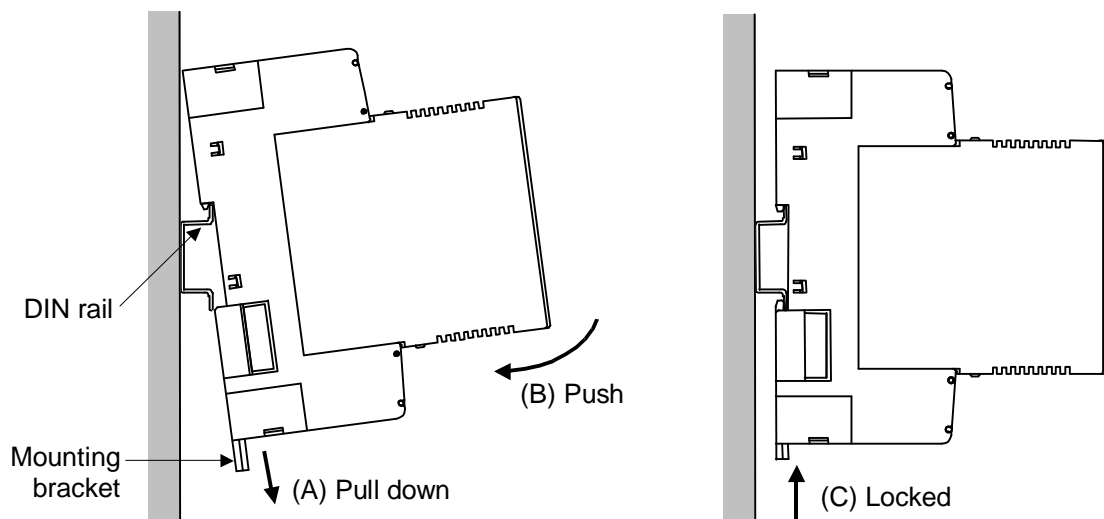

■ Removing procedures

1. Turn the power OFF.
2. Remove the wiring.
3. Pull down a mounting bracket with a blade screwdriver (A). Lift the instrument from bottom, and take it off (B).

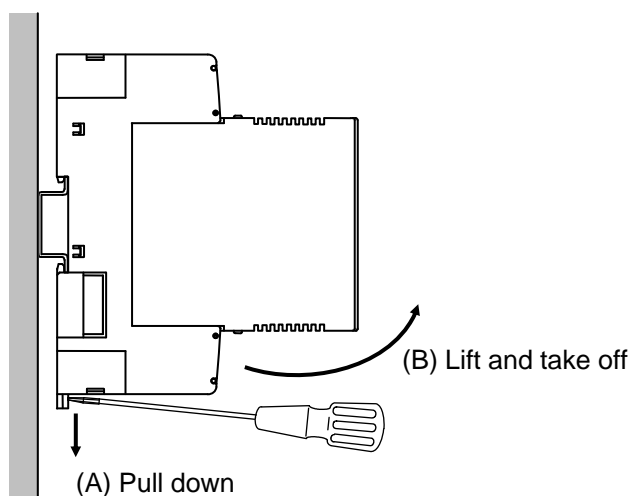

3.4 Panel Mounting

■ Mounting procedures

1. Pull down the mounting bracket (A) until locked and that a mounting hole appears.
2. Prepare one mounting bracket per instrument (B) sold separately (KSRX-55) and then insert it in the rear of the terminal board at top of the instrument until locked but a mounting hole does not disappear.
3. Mount each module directly on the panel with screws which are inserted in the mounting holes of the top and bottom mounting brackets.

Recommended tightening torque: 0.3 N·m (3 kgf·cm)



The customer needs to provide the M3 size screws. Select the screw length that matches the mounting panel.

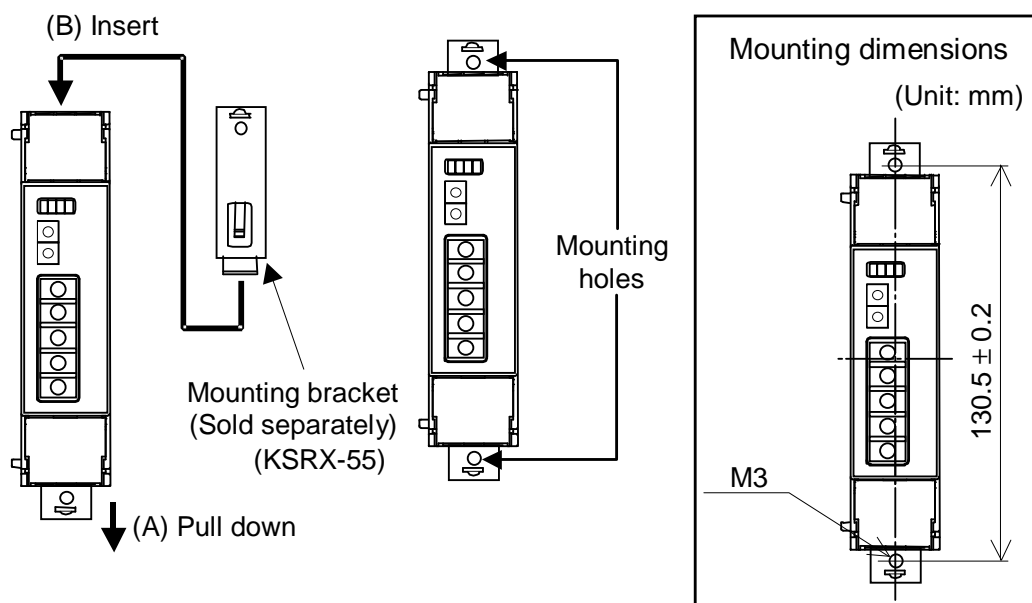

4. WIRING

This chapter describes wiring cautions, terminal configuration and connections.

4.1 Wiring Cautions



WARNING

- To prevent electric shock or instrument failure, do not turn on the power until all wiring is completed. Make sure that the wiring is correct before applying power to the instrument.
 - To prevent electric shock or instrument failure, turn off the power before connecting or disconnecting the instrument and peripheral equipment.
-
- To avoid noise induction, keep communication signal wire away from instrument power line, load lines and power lines of other electric equipment.
 - If there is electrical noise in the vicinity of the instrument that could affect operation, use a noise filter.
 - Shorten the distance between the twisted power supply wire pitches to achieve the most effective noise reduction.
 - Always install the noise filter on a grounded panel. Minimize the wiring distance between the noise filter output and the instrument power supply terminals to achieve the most effective noise reduction.
 - Do not connect fuses or switches to the noise filter output wiring as this will reduce the effectiveness of the noise filter.
 - Power supply wiring must be twisted and have a low voltage drop.
 - For an instrument with 24 V power supply, supply power from a SELV circuit.
 - A suitable power supply should be considered in the end-use equipment. The power supply must be in compliance with a limited-energy circuits (maximum available current of 8 A).
 - Use the solderless terminal appropriate to the screw size (M3).

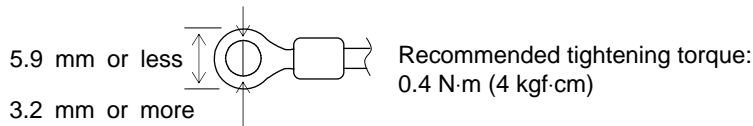



- Make sure that the any wiring such as solderless terminal is not in contact with the adjoining terminals.

4.2 Terminal Configuration

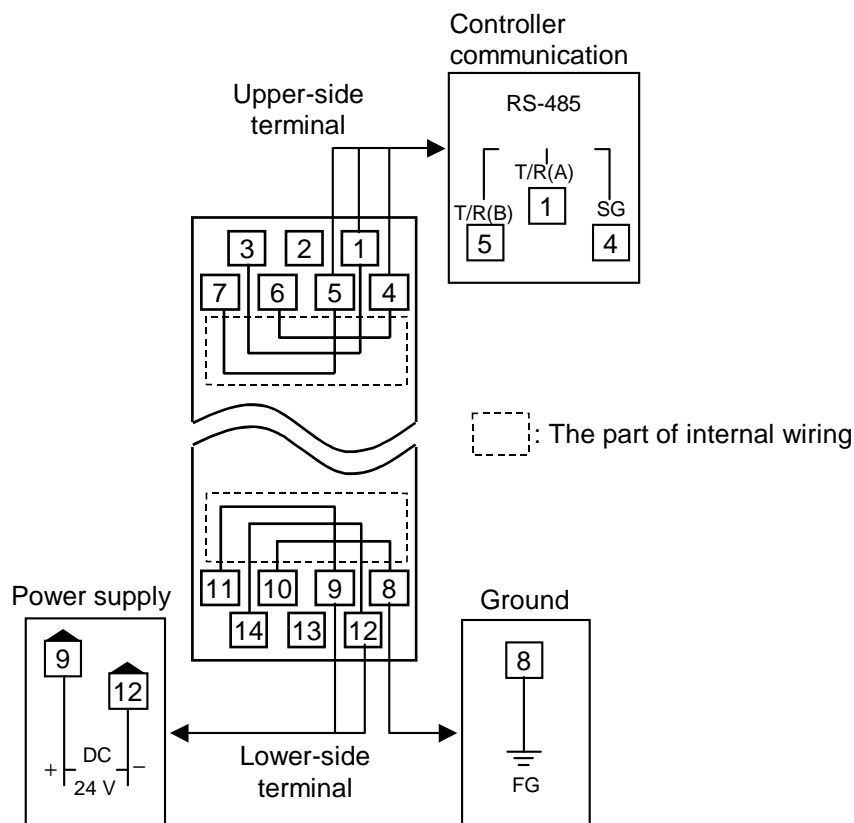
The terminal layout is as follows.



-  As controller communication terminal No. 1, 4 and 5 are internally connected to terminal No. 3, 6 and 7, any terminals can be used.
-  As ground and power supply terminal No. 8, 9 and 12 are internally connected to terminal No. 10, 11 and 14, any terminals can be used.
-  Terminal No. 2 and No. 13 is not used.

4.3 Connection to PLC

■ Connection method

The PLC (Master station) and COM-JC make multi-drop connection in CC-Link dedicated cable Ver. 1.10.

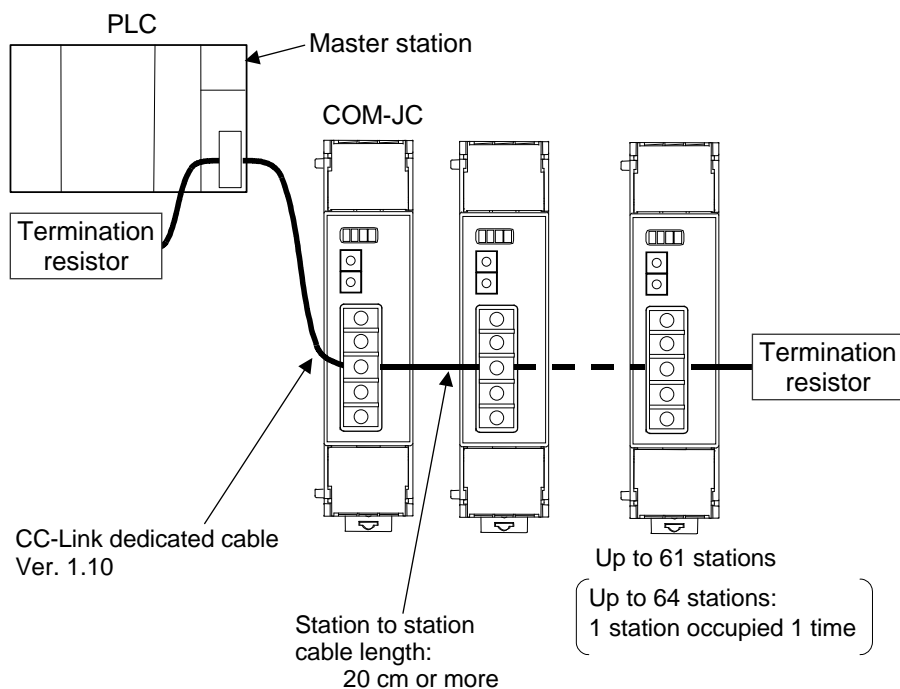

● Communication speed and maximum transmitter distance
(Use the CC-Link dedicated cable Ver. 1.10)

Communication speed	Station to station cable length	Maximum transmitter distance (maximum length of network)
10 Mbps	20 cm or more	100 m
5 Mbps		160 m
2.5 Mbps		400 m
625 kbps		900 m
156 kbps		1200 m

■ Terminal numbers and signal details

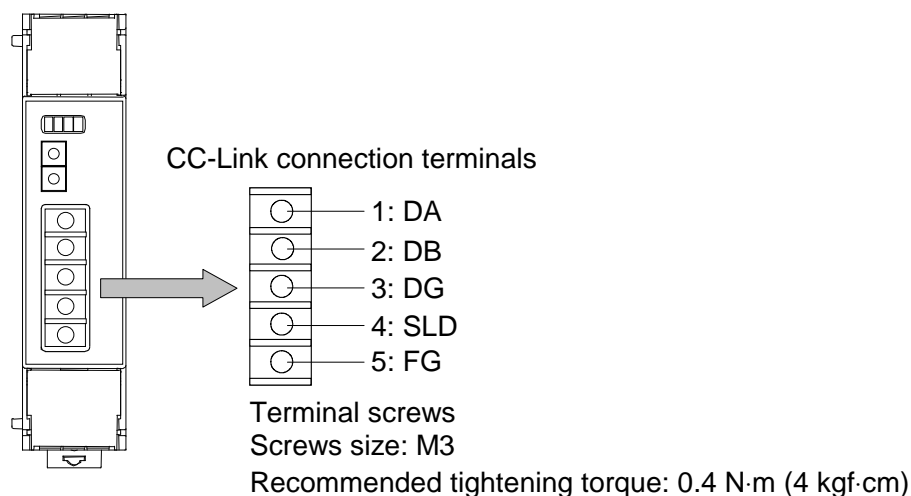

Terminal No.	Signal name	Symbol	Cable color
1	Data A	DA	Blue
2	Data B	DB	White
3	Data ground	DG	Yellow
4	Shield	SLD	Grounding wire (Shield)
5	Frame ground	FG	—

The CC-Link connecting terminal cannot do on-line installation or dismount for terminal block of dismount impossibility. The device cannot be replaced unless the link is set offline. In addition, FG (flame ground) terminal of terminal number 5 is FG in a CC-Link function, and it is not FG of instrument all.

Ground both ends of the shield wire on the twisted pair cable via the SLD or FG terminal of each module. In addition, the SLD terminal is internally connected with the FG terminal.

Do not ground the instrument together with other equipment.

In addition, use grounding wires with across section of 2.0 mm² or more. (Ground resistance: 100 Ω or less)

For cable specifications, connection method and vendor, refer to the website of CC-Link Partner Association.

<http://www.cc-link.org/>

■ Connection diagram

 Always connect a termination resistor between the DA and DB terminals of the module to be located at the far end.

Termination resistor: $110 \Omega \pm 5 \% 1/2 W$

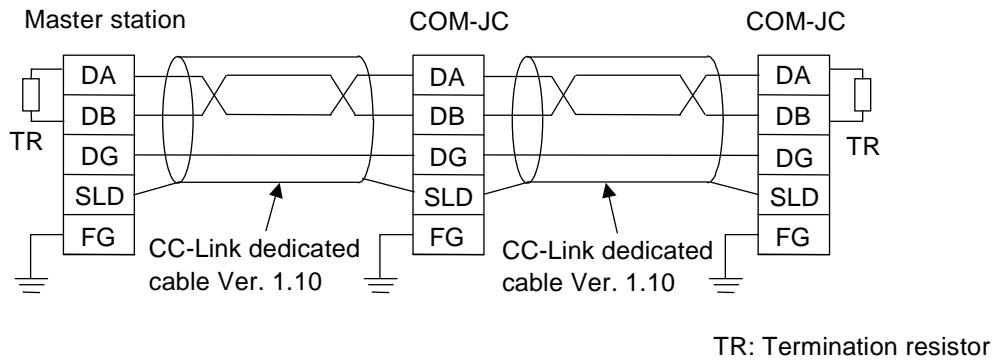

 The CC-Link dedicated cable Ver. 1.10 is provided by the customer.

4.4 Connection to Controller

Conduct wiring between the COM-JC and controller (SRZ) as shown in the following.

■ Z-TIO module or Z-DIO module communication terminal number and signal details

Terminal No.	Signal name	Symbol
3	Send/receive data	T/R (A)
4	Send/receive data	T/R (B)
5	Signal ground	SG

■ Wiring

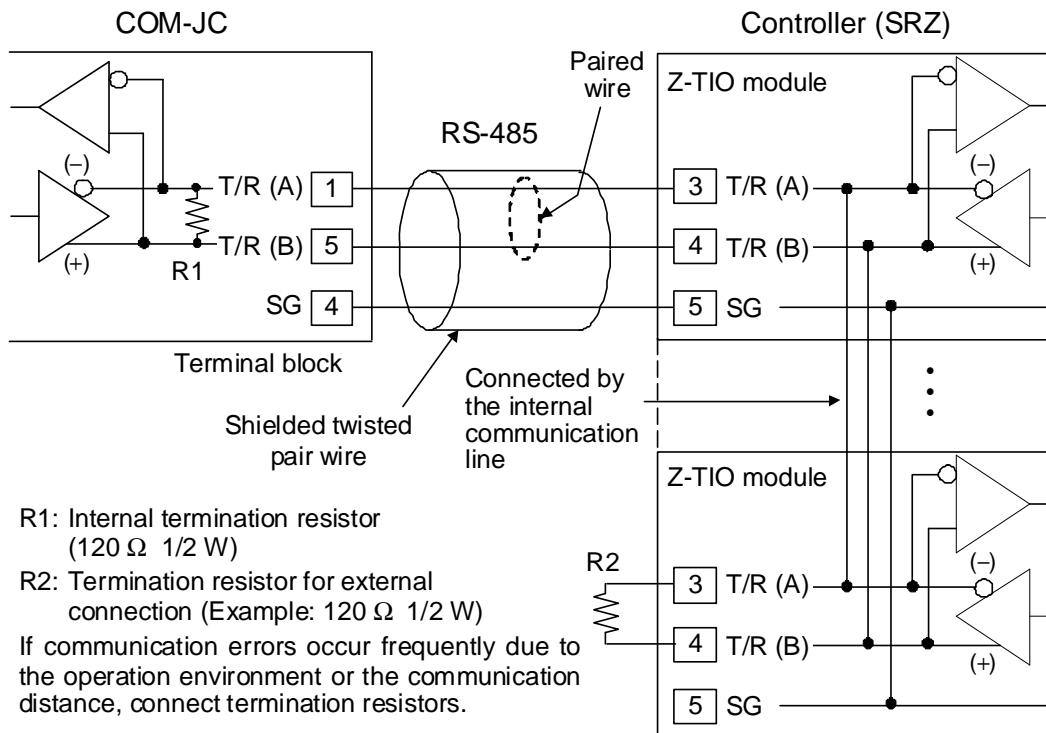

R1: Internal termination resistor
(120 Ω 1/2 W)

R2: Termination resistor for external
connection (Example: 120 Ω 1/2 W)

If communication errors occur frequently due to the operation environment or the communication distance, connect termination resistors.

 For the termination resistors, refer to **4.5 Installation of Termination Resistor (P. 14)**.

Up to 16 Z-TIO modules can be connected.

The maximum number of SRZ modules (including other function modules) on the same communication line is 31.
(Connectable module type to COM-JC: Z-TIO-A, Z-TIO-B, Z-DIO-A)



The cable and termination resistors must be provided by the customer.



The termination resistor existing within the COM-JC can be connected or disconnected by the switch. (Factory set value: Termination resistor connected)

4.5 Installation of Termination Resistor

If communication errors occur frequently due to the operation environment or the communication distance, connect termination resistors to the COM-JC and the controller. Procedure for setting a termination resistor to controller communication (RS-485) and its setting position are described in the following.

■ Termination resistor setting position

If the COM-JC is connected to the extreme end of the communication line, install one termination resistor each to the COM-JC and the controller located most distantly from the COM-JC.

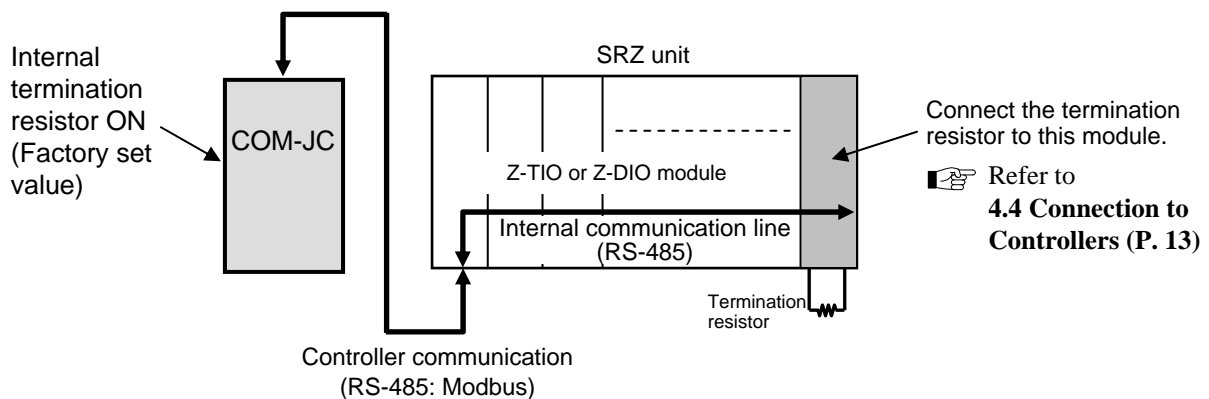

■ Setting procedure of termination resistor (COM-JC)

As the COM-JC is internally provided with a selector switch for choosing the ON/OFF of a termination resistor, it is not required to externally install the termination resistor.

(Factory set value: ON: Termination resistor connected)

1. Turn off the power supply of the COM-JC.
Do not separate the mainframe from terminal base with the power turned on. If so, instrument failure may result.
2. Pull out the mainframe itself toward you while pushing the locks at its top and bottom (1), and then separate it from the terminal base (2).

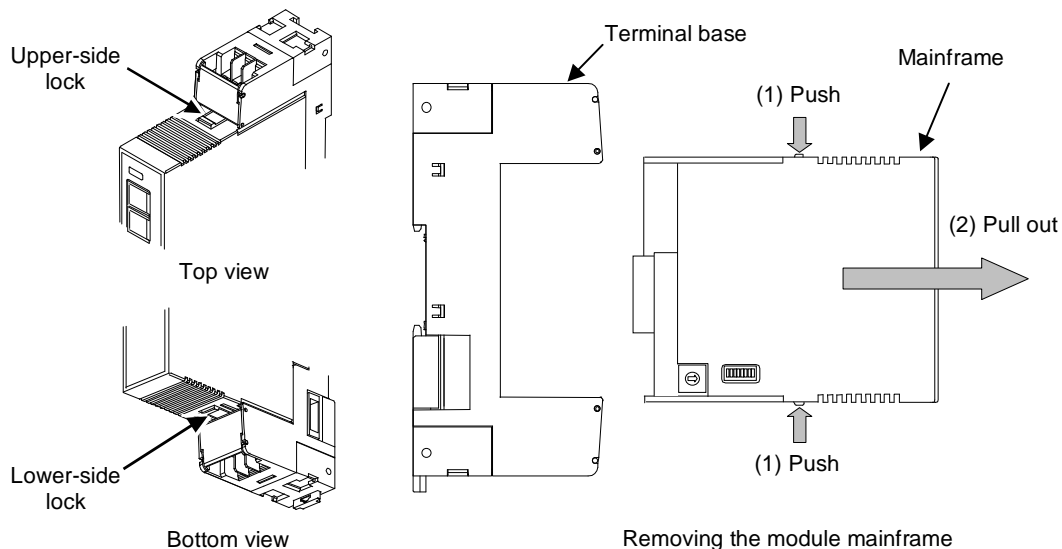

3. Turn on the termination resistor transfer switch in the terminal base.

The COM-JC is shipped from the factory with the selector switch set to “ON: Termination resistor connected.”

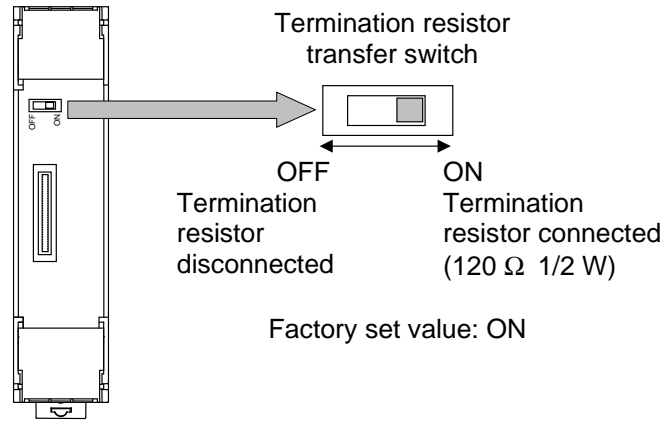

A terminal base of the state which removed module mainframe

4. Push the mainframe thus separated in the terminal base until firmly locked.

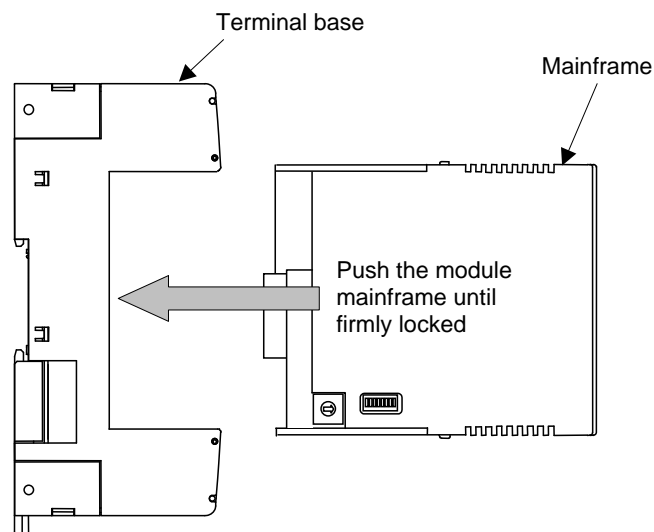

Mounting the module mainframe

5. SETTING



WARNING

- To prevent electric shock or instrument failure, always turn off the power before setting the switch.
- To prevent electric shock or instrument failure, never touch any section other than those instructed in this manual.

CAUTION

Do not separate the mainframe from the terminal base with the power turned on. If so, instrument failure may result.

5.1 Station Number Setting

Set the station number of CC-Link. For this setting, use a small blade screwdriver.



When set to any value out of the setting range, the COM-JC becomes the FAIL state.

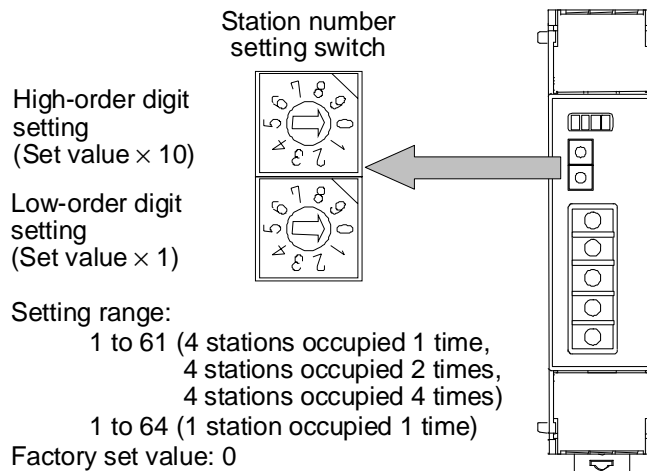

5.2 Communication Speed Setting

The rotary switch at the left side of the mainframe sets the communication speed of the CC-Link. For this setting, use a small slotted screwdriver.

 When set to any value out of the setting range, the COM-JC becomes the FAIL state.

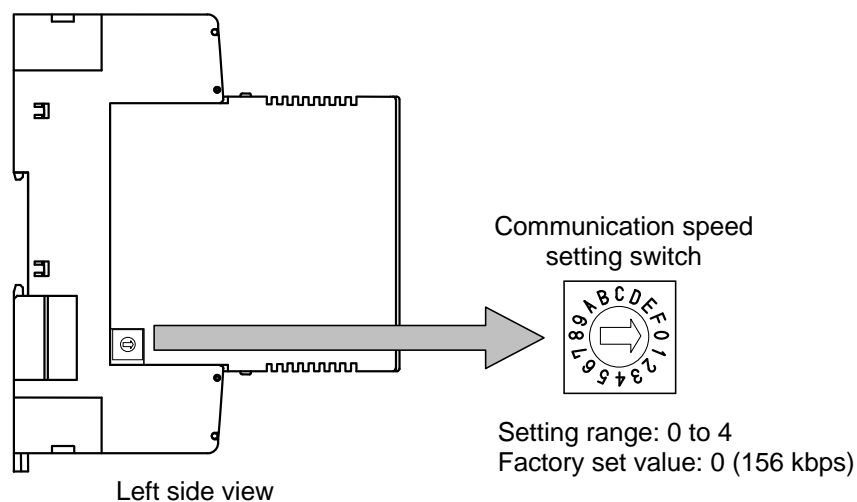

- Communication speed and maximum transmitter distance
(Use the CC-Link dedicated cable Ver. 1.10)

Communication speed setting	Communication speed	Maximum transmitter distance (maximum length of network)
0	156 kbps	1200 m
1	625 kbps	900 m
2	2.5 Mbps	400 m
3	5 Mbps	160 m
4	10 Mbps	100 m

5.3 Number of Occupied Station/Extended Cyclic and Controller Communication Speed Setting

The DIP switch at the left side of the mainframe sets the occupied station/extended cyclic and controller communication speed.

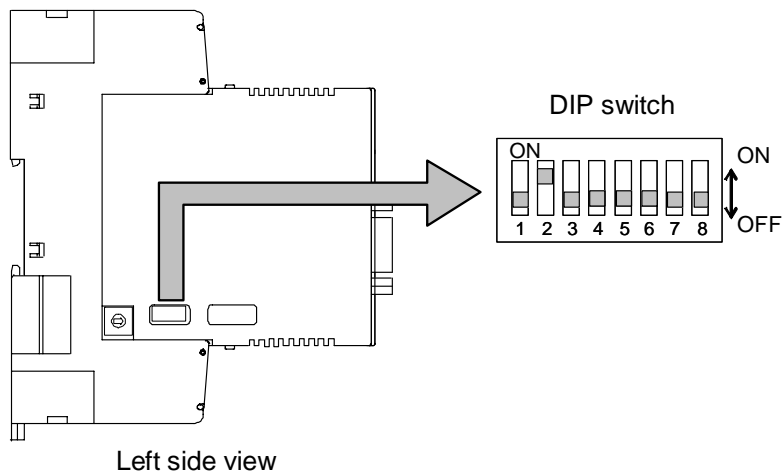

1	2	Controller communication speed
OFF	OFF	38400 bps
ON	OFF	9600 bps
OFF	ON	19200 bps
ON	ON	38400 bps

Factory set value: 19200 bps

3	4	5	Number of occupied station/extended cyclic
OFF	OFF	OFF	4 stations occupied 1 time (8 channels assignment)
ON	OFF	OFF	4 stations occupied 1 time (16 channels assignment)
OFF	ON	OFF	4 stations occupied 2 times (16 channels assignment)
ON	ON	OFF	4 stations occupied 2 times (32 channels assignment)
OFF	OFF	ON	1 station occupied 1 time (1 channel assignment)
ON	OFF	ON	1 station occupied 1 time (2 channels assignment)
OFF	ON	ON	4 stations occupied 4 times (32 channels assignment)
ON	ON	ON	4 stations occupied 4 times (64 channels assignment)

Factory set value: 4 stations occupied 1 time (8 channels assignment)

CC-Link version varies according to the specification of Occupied station/Extended cyclic of the COM-JC. Select CC-Link version of PLC by setting the following CC-Link specifications:

- 1 station occupied 1 time/4 stations occupied 1 time: CC-Link Ver. 1.10
- 4 stations occupied 2 times/4 stations occupied 4 times: CC-Link Ver. 2.00

6	7	8	
OFF	OFF	OFF	Fixed

5.4 Controller Setting

[Controller communication conditions]

- Module address (Controller address):

1 to 99



For the Z-TIO module, the value obtained by adding “1” to the set address corresponds to the address used for the actual program.

For the Z-DIO module, the value obtained by adding “17” to the set address corresponds to the address used for the actual program.

- Communication protocol: Modbus-RTU
- Communication speed: 9600 bps, 19200 bps, 38400 bps



Match the communication speed of the FB series controller to that of the COM-JC. The communication speed of the COM-JC can be adjusted with a DIP switch. (Refer to page 18)

- Data bit configuration: Data 8-bit, Without parity bit, Stop 1-bit



For setting procedure, refer to **Z-TIO Host Communication Quick Instruction Manual (IMS01T02-E□)** or **Z-DIO Instruction Manual (IMS01T03-E□)**.

6. CC-Link COMMUNICATION

6.1 Communication Between Master Station and COM-JC (Remote Device Station)

The COM-JC which is a remote device station can process remote input (RX), remote output (RY) and remote registers (RWw and RWr).

■ Outline of communication between master station and COM-JC (remote device station)

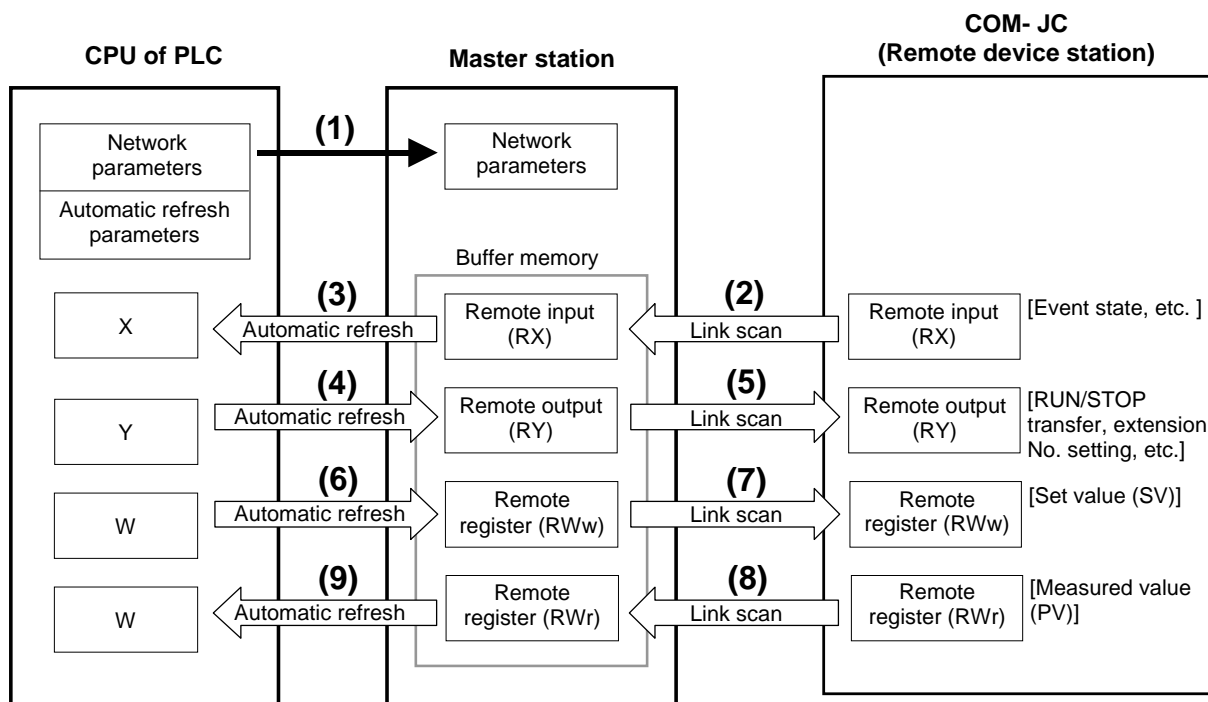

- | | |
|---|---|
| <p>(1) When the PLC system is powered on, the network parameters in the PLC CPU are transferred to the master station, and the CC-Link system automatically starts up.</p> <p>(2) The remote input RX of a COM-JC (remote device station) is stored automatically (for each link scan) in the master station's "remote input RX" buffer memory.</p> <p>(3) The input status stored in the "remote input RX" buffer memory is stored in the CPU device set with the automatic refresh parameters.</p> <p>(4) The on/off data of the CPU device set with the automatic refresh parameters is stored in the "remote output RY" buffer memory.</p> <p>(5) Remote output RY is automatically set to on/off (for each link scan) according to the output status stored in the "remote output RY" buffer memory.</p> | <p>[Data link startup]</p> <p>[Remote input]</p> <p>[Remote output]</p> |
|---|---|

-
- | | |
|--|--|
| <p>(6) The transmission data of the CPU device set with the automatic refresh parameters is stored in the “remote register RWw” buffer memory.</p> <p>(7) The data stored in the “remote register RWw” buffer memory is automatically sent to the remote register RWw of COM-JC (remote device station).</p> | [Writing to the remote register RWw] |
| <p>(8) The remote register RWr data of a COM-JC (remote device station) is automatically stored in the “remote register RWr” buffer memory of the master station.</p> <p>(9) The remote register RWr data of a COM-JC (remote device station) stored in the “remote register RWr” buffer memory is stored in the CPU device set with the automatic refresh parameters.</p> | [Reading from the remote register (RWr)] |



With the master station (PLC) set to the STOP state, neither the remote output (RY) nor data write to the remote register (RWw) is reflected to the COM-JC.



For details of the communication, refer to the **Instruction manual for PLC**.

6.2 CC-Link Flag Operation

Remote input/output and remote register flag operations are as follows.

[Example] When the occupied station/extended cyclic of COM-JC is set to 4 stations occupied 1 time.

■ Initialize request processing at power on

● Initialize processing request from remote device station (COM-JC)

If the COM-JC is initialized at power on, the initialize data processing request flag [RX(n+7)8] is turned on. Thus, turn on the initialize data processing completion flag [RY(n+7)8].

When COM-JC becomes a ready state, a remote ready [RX(n+7)B] is turned on.

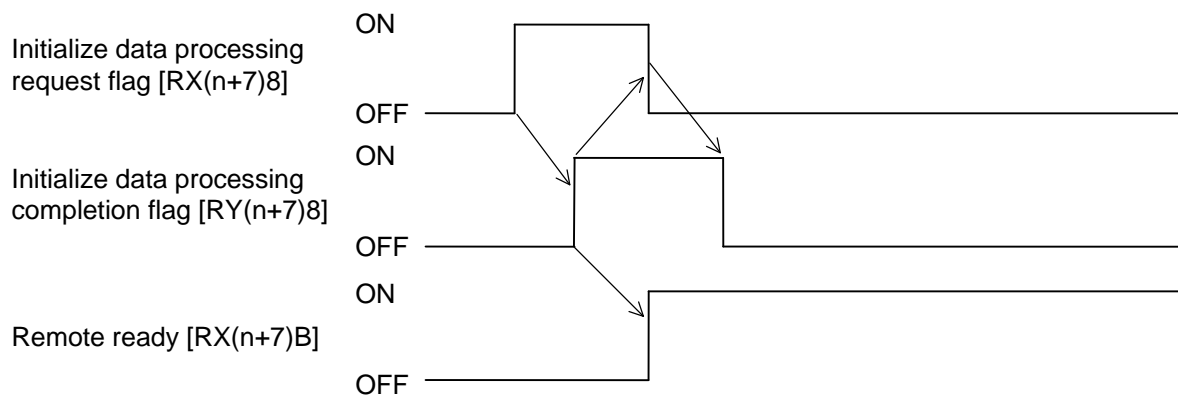

● Initialize processing request from master station (PLC)

This is a COM-JC initialize setting request. As there is no initialize data specifically, no processing is required.

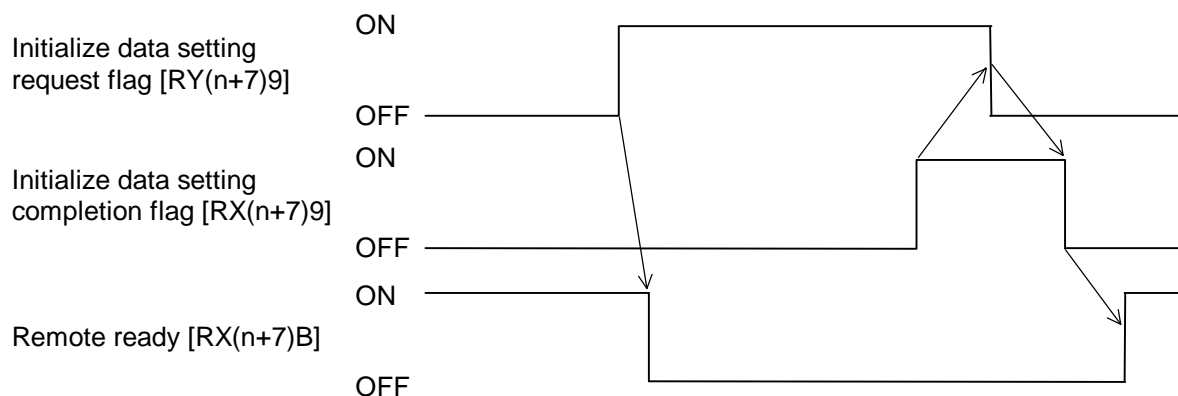

■ Error flag/error reset processing

If the Error reset request flag [RY(n+7)A] is turned on while the Error status flag [RX(n+7)A] is turned on, the Error status flag history is cleared and the flag [RX(n+7)A] turns off.

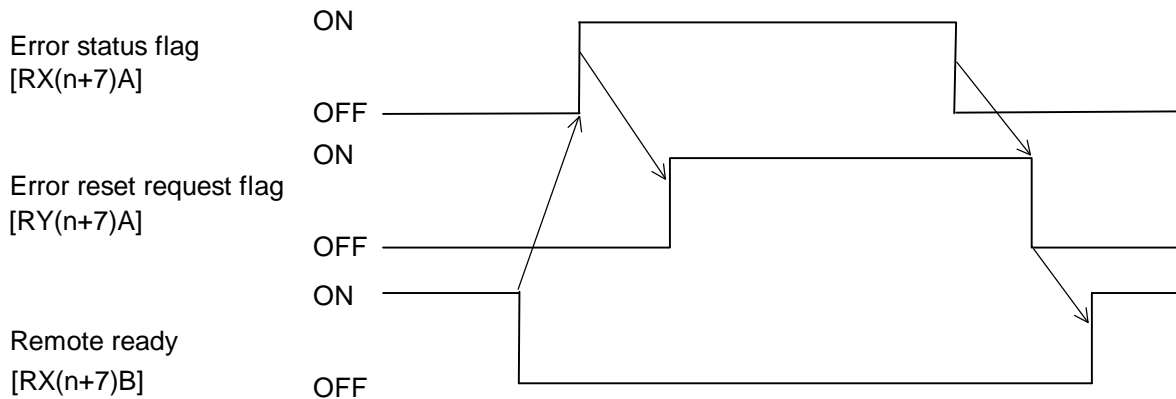

■ Extension number for display selection processing

The content of the extended display remote register is selected.

After the extension number for display [RYn0 to RYn5, RY(n+1)0 to RY(n+1)2] is set, turn on the extended display flag [RYnC]. After the data in the remote register [RWrn to RWrn+F] is displayed, check that extended display completion [RXnC] is turned on and then turn off the extended display flag [RYnC]. If the extended display flag is turned off, the extended display completion is turned off.

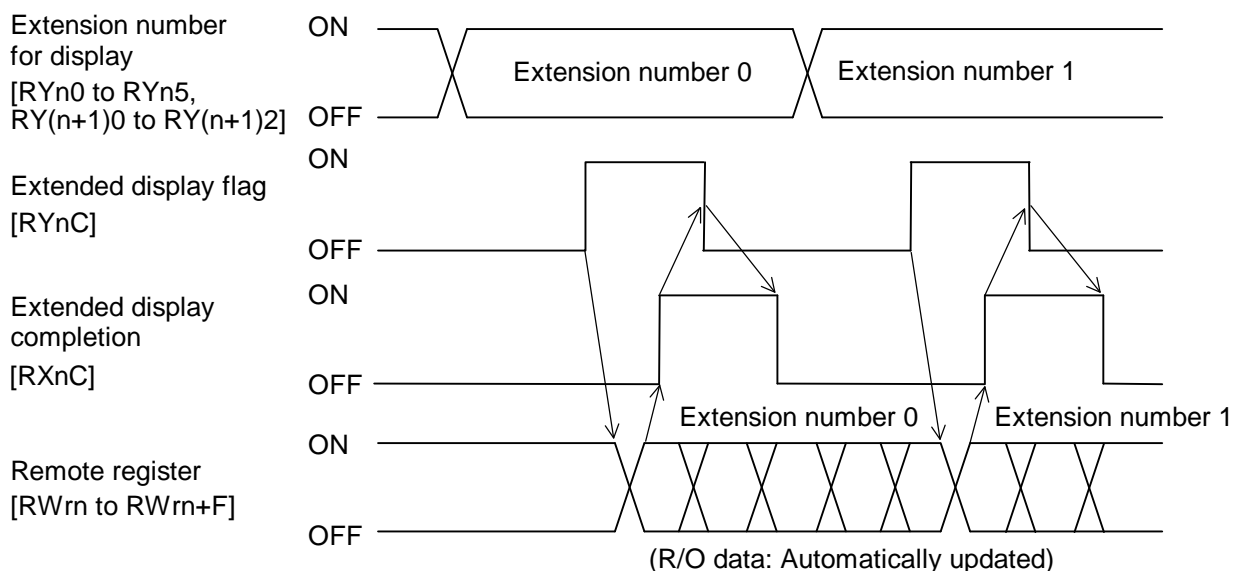

■ Extension number for setting selection processing

The content of the extended setting remote register is selected and the set value is changed. After the extension number for setting [RYn6 to RYnB, RY(n+1)8 to RY(n+1)A] is set, turn on the extended setting flag (Setting update flag) [RYnD]. After the content of the remote register [RWwn to RWwn+F] is set, check that extended setting completion [RXnD] is turned on and then turn off the extended setting flag (Setting update flag) [RYnD]. If the extended setting flag (Setting update flag) [RYnD] is turned off, the extended setting completion [RXnD] is turned off.

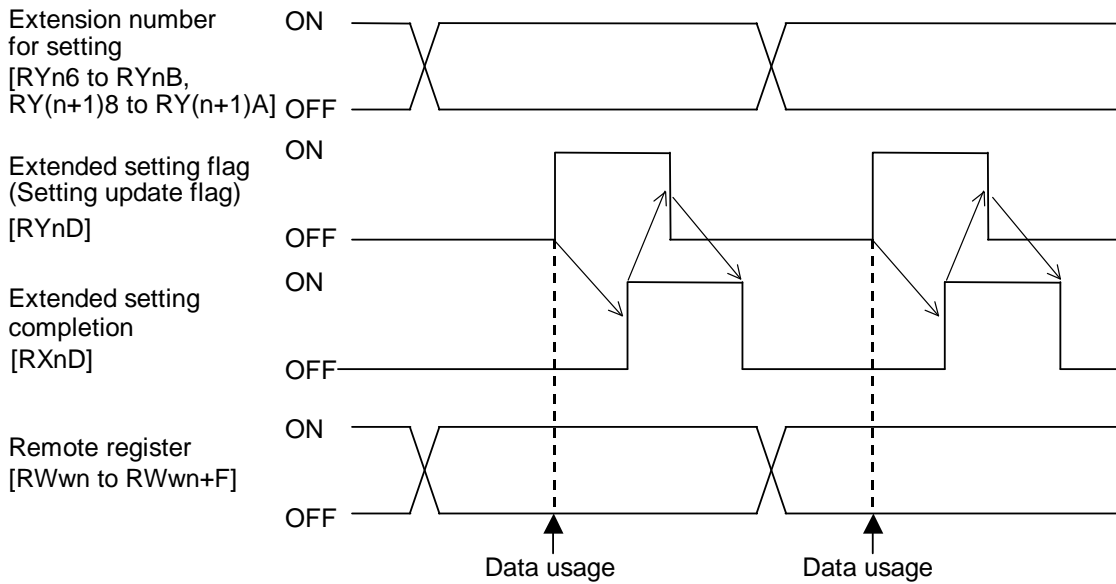

Regardless of the number of occupied station and the extended cyclic, the above processing is also necessary if the “set value (SV)” assigned to the remote register (RWw) as a fixed value is changed.

■ AT start procedure

Instructs AT execution.

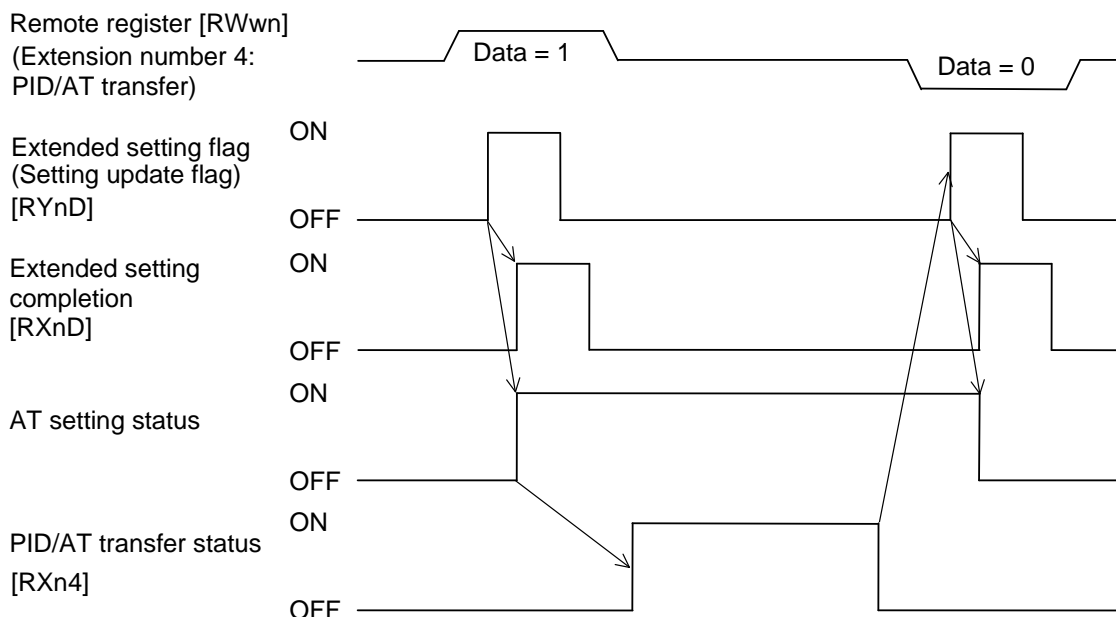

6.3 Processing of Numeric Data Values

Numeric data values used via communication with the PLC and processed by COM-JC include those with and without decimal points and also those with minus signs.

- **For numeric data value without decimal point**

If there is no decimal point, the value is processed as it is.

In parameters which only have ON or OFF status, 1 = ON, 0 = OFF.

[Example]

A signal wire for temperature input is disconnected and the burnout state occurs.

→ Read value corresponding to extension number 63 (comprehensive event state):

1 (Hexadecimal number: 0001H)

- **For numeric data value with decimal point**

The decimal point is omitted.

[Example]

When temperature measured value (PV) of controller (module address 1) is 120.5 °C

→ Read value of remote register (RWrn) [measured value (PV) of module address 1]:

1205 (Hexadecimal number: 04B5H)

→ Read value corresponding to extension number 0 [measured value (PV)]:

1205 (Hexadecimal number: 04B5H)

- **For numeric data value with minus sign**

The value is expressed as a 2's complement value which is obtained by subtracting the minus value from the hexadecimal number 10000H.

[Example]

When temperature measured value (PV) of controller (module address 1) is -2.5 °C

→ Read value of remote register (RWrn) [measured value (PV) of module address 1]:

Hexadecimal number: FFE7H ($10000H - 25 = 10000H - 19H = FFE7H$)

→ Read value corresponding to extension number 0 [measured value (PV)]:

Hexadecimal number: FFE7H ($10000H - 25 = 10000H - 19H = FFE7H$)



Read data of unused item becomes 0.



Any attempt to write to an unused item is not processed as an error. Data cannot be written into an unused item.

6.4 Module Address and Number of CC-Link Assignment Channels

■ Z-TIO module

- Module address setting range: 1 to 16
- The number of assignment channel per module (when connected to COM-JC): 4 channels
- The number of the maximum available modules per the number of the CC-Link assignment channel

1 station occupied 1 time (1 channel assignment or 2 channels assignment):	1 module
4 stations occupied 1 time (8 channels assignment):	2 modules
4 stations occupied 1 time and 4 stations occupied 2 times (16 channels assignment):	4 modules
4 stations occupied 2 times and 4 stations occupied 4 times (32 channels assignment):	8 modules
4 stations occupied 4 times (64 channels assignment):	16 modules
- The following table shows the relation between the channel number (when set with the number continuous from module address 1) and the number of the available CC-Link assignment channel against each module address.

Module Address		1	2	3	4	5	6	7	8	16	
Channel number		CH1 CH2 CH3 CH4	CH5 CH6 CH7 CH8	CH9 CH10 CH11 CH12	CH13 CH14 CH15 CH16	CH17 CH18 CH19 CH20	CH21 CH22 CH23 CH24	CH25 CH26 CH27 CH28	CH29 CH30 CH31 CH32	CH61 CH62 CH63 CH64	
Number of CC-Link assignment channels	4 stations occupied 1 time	8 channels assignment		A	—	—	—	—	—	—	—	
	4 stations occupied 2 times	16 channels assignment		A, B		B		—	—	—	—	
		32 channels assignment		A, B, C		B, C		C			—	—
	4 stations occupied 4 times	32 channels assignment		A, B, C		B, C		C			—	—
		64 channels assignment		A, B, C, D		B, C, D		C, D			D	

A: Range of number of CC-Link assignment channels that can be set when the module address setting is 1 and 2 (up to CH8).

B: Range of number of CC-Link assignment channels that can be set when the module address setting is 1 to 4 (up to CH16).

C: Range of number of CC-Link assignment channels that can be set when the module address setting is 1 to 8 (up to CH32).

D: Range of number of CC-Link assignment channels that can be set when the module address setting is 1 to 16 (up to CH64).

Example: When three Z-TIO modules (4-channel type) are joined together and the module addresses are 1, 2 and 3, a number in the B range (16 or more channels when 4 stations occupied 1 time is set) can be set for the number of CC-Link assignment channels.



For 1 station occupied 1 time, the number of CC-Link assignment channels is 1 channel or 2 channels, and thus only CH1 or CH2 can be used when the module address is “1”; the data of CH3 and CH4 cannot be handled. For this reason, caution is required when 1 station occupied 1 time is used.



When the module address is set to “free,” the channel number of the first module are CH1 to CH4. Even if the address of the second module is not continuous from the address of the first module, the channel numbers are continuous.

Example: When two Z-TIO modules (4-channel type) are connected, assuming that the module addresses are 3 and 6, the channel number of the module address 3 is CH1 to CH4 and the channel number of the module address 6 is CH5 to CH8.

In this case, as two modules are used, the number of CC-Link assignment channel with 4 stations occupied 1 time setting (8 channels assignment) or larger is settable.

-  The number of occupied station/extended cyclic and number of CC-Link assignment channels is set by the DIP switch. For the setting procedure, refer to **5.3 Number of Occupied Station/Extended Cyclic and Controller Communication Speed Setting (P. 18)**.

■ Z-DIO module

- Module address setting range: 17 to 32
- The number of assignment channel per module (when connected to COM-JC): 8 channels
- The number of the maximum available modules per the number of the CC-Link assignment channel
 - 1 station occupied 1 time (1 channel assignment or 2 channels assignment): 1 module
 - 4 stations occupied 1 time (8 channels assignment): 1 modules
 - 4 stations occupied 1 time and 4 stations occupied 2 times (16 channels assignment): 2 modules
 - 4 stations occupied 2 times and 4 stations occupied 4 times (32 channels assignment): 4 modules
 - 4 stations occupied 4 times (64 channels assignment): 8 modules
- The following table shows the relation between the channel number (when set with the number continuous from module address 17) and the number of the available CC-Link assignment channel against each module address.

When module addresses are set with continuous numbers starting from 17, available module addresses are from 17 to 24. (The maximum number of CC-Link assignment channel is 64)

Module Address		17	18	19	20	21	22	23	24	32
Channel number		CH1	CH9	CH17	CH25	CH33	CH41	CH49	CH57	CH121
		CH2	CH10	CH18	CH26	CH34	CH42	CH50	CH58		CH122
		CH3	CH11	CH19	CH27	CH35	CH43	CH51	CH59		CH123
		CH4	CH12	CH20	CH28	CH36	CH44	CH52	CH60		CH124
		CH5	CH13	CH21	CH29	CH37	CH45	CH53	CH61		CH125
		CH6	CH14	CH22	CH30	CH38	CH46	CH54	CH62		CH126
		CH7	CH15	CH23	CH31	CH39	CH47	CH55	CH63		CH127
		CH8	CH16	CH24	CH32	CH40	CH48	CH56	CH64		CH128
Number of CC-Link assignment channels	4 stations occupied 1 time	8 channels assignment	A	—	—	—	—	—	—	—	—
		16 channels assignment	A,B	B	—	—	—	—	—	—	—
	4 stations occupied 2 times	16 channels assignment	A,B	B	—	—	—	—	—	—	—
		32 channels assignment	A,B,C	B,C	C		—	—	—	—	—
	4 stations occupied 4 times	32 channels assignment	A,B,C	B,C	C		—	—	—	—	—
		64 channels assignment	A,B,C,D	B,C,D	C, D		D				—

A: Range of number of CC-Link assignment channels that can be set when the module address setting is 17 (up to CH8).

B: Range of number of CC-Link assignment channels that can be set when the module address setting is 17 and 18 (up to CH8).

C: Range of number of CC-Link assignment channels that can be set when the module address setting is 17 to 20 (up to CH32).

D: Range of number of CC-Link assignment channels that can be set when the module address setting is 17 to 24 (up to CH64).

Example: When two Z-DIO modules are joined together and the module addresses are 17 and 18, a number in the B range (16 or more channels when 4 stations occupied 1 time is set) can be set for the number of CC-Link assignment channels.



For 1 station occupied 1 time, the number of CC-Link assignment channels is 1 channel or 2 channels, and thus only CH1 or CH2 can be used when the module address is “17”; the data of CH3 to CH8 cannot be handled. For this reason, caution is required when 1 station occupied 1 time is used.

 When the module address is set to “free,” the channel number of the first module are CH1 to CH8. Even if the address of the second module is not continuous from the address of the first module, the channel numbers are continuous.

 The number of occupied station/extended cyclic and number of CC-Link assignment channels is set by the DIP switch. For the setting procedure, refer to **5.3 Number of Occupied Station/Extended Cyclic and Controller Communication Speed Setting (P. 18)**.

■ **The number of channels by data difference**

The number of channels used varies depending on the data type.

- For a Z-TIO module (4-channel type), 4 channels are used for channel-based data, however, only 1 channel is used for module-based data.
- For a Z-DIO module, 8 channels are used for channel-based data, however, only 1 channel is used for module-based data.

Example 1 When 16 Z-TIO modules (4-channel type) are connected
 Channel-based data: 64 channels are used.
 Module-based data: 16 channels are used.

Example 2 When three Z-TIO modules (4-channel type) and one Z-DIO module are connected, the channels to be used are as follows.

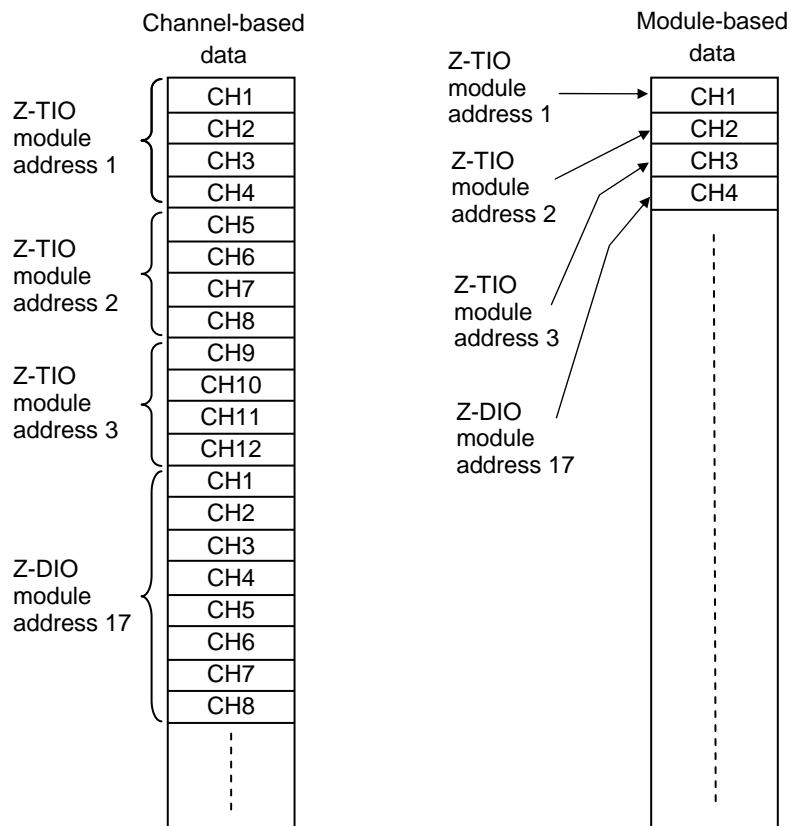

7. COMMUNICATION DATA LIST

7.1 Remote Input/Output

Remote input (RX) and remote output (RY) is ON/OFF data.

“n” in the table is the address assigned to the master station by the station number setting.

■ When the number of occupied station/extended cyclic settings are the same

It can be calculated by the following equation. However, the computing equation is when a network is configured only by using our COM-JCs and the number of all exclusive stations/extended cyclic are at the same setting.

Number of occupied station/ extended cyclic setting	Equation
1 station occupied 1 time	$n = (\text{Station number}^* - 1) \times 2$
4 stations occupied 1 time	$n = (\text{Station number}^* - 1) \times 2$
4 stations occupied 2 times	$n = (\text{Station number}^* - 1) \times 3.5$
4 stations occupied 4 times	$n = (\text{Station number}^* - 1) \times 7$

* Station number when there is one occupied station: 1 to 64 (each number can be set)
 Station number when there are four occupied stations: 1 to 61
 (four stations are occupied for each station number, and thus only numbers that are increments of four can be set: 1, 5, 9 ...61)

As the calculation result is expressed in decimal number it is converted to hexadecimal number before substituted for “n” in the table.

Example: When the COM-JC is set to 4 stations occupied 1 time and its station number is “5.”

$$n = (5 - 1) \times 2 = 8 \text{ (Decimal number)} \rightarrow 8 \text{ (Hexadecimal number)}$$

For station number 5: Remote inputs RXn0 to RX (n+7) F → RX80 to RXFF
 Remote outputs RYn0 to RY (n+7) F → RY80 to RYFF

■ When the number of occupied station/extended cyclic settings are different

If the network consists of COM-JC modules with differing “number of occupied station/extended cyclic” settings, use for “n” the total of the highest digits (1C: 4 stations occupied 4 times) of the number of assigned registers with station number lower than the module’s own station in order from the lowest station number.

Number of occupied station/ extended cyclic setting	Number of assigned registers
1 station occupied 1 time	20H (Hexadecimal number)
4 stations occupied 1 time	80H (Hexadecimal number)
4 stations occupied 2 times	E0H (Hexadecimal number)
4 stations occupied 4 times	1C0H (Hexadecimal number)

Example: Calculation of “n” when the network consists of three COM-JC modules and the station numbers and “number of occupied station/extended cyclic” settings are as shown below.

1st module [Station number 1]: 4 stations occupied 2 times

n = 0 (No station numbers less than the module’s own station, thus 0)

Remote inputs: RXn0 to RX (n+D) F → RX00 to RXDF

Remote outputs: RYn0 to RY (n+D) F → RY00 to RYDF

2nd module [Station number 5]: 1 station occupied 1 time

n = E (Highest digit of E0H, the number of assigned registers of station 1)

Remote inputs: RXn0 to RX (n+1) F → RXE0 to RXFF

Remote outputs: RYn0 to RY (n+1) F → RYE0 to RYFF

3rd module [Station number 6]: 4 stations occupied 1 time

n = E + 2 = 10

(Total of highest digits of E0H and 20H, the number of assigned registers of station 1 and station 5)

Remote inputs: RXn0 to RX (n+7) F → RX100 to RX17F

Remote outputs: RYn0 to RY (n+7) F → RY100 to RY17F

7.1.1 1 station occupied 1 time

■ Remote input

Data direction: COM-JC (Remote device station) → Master station (PLC)

Data capacity: 32-bit

Address	Communication item		Data range	Factory set value
RXn0	CH1	Event 1 state	0: OFF 1: ON	—
RXn1		Event 2 state		—
RXn2		Burnout state		—
RXn3		Heater break alarm (HBA) state		—
RXn4		PID/AT transfer		0: PID control 1: Autotuning (AT)
RXn5	CH2	Event 1 state	0: OFF 1: ON	—
RXn6		Event 2 state		—
RXn7		Burnout state		—
RXn8		Heater break alarm (HBA) state		—
RXn9		PID/AT transfer		0: PID control 1: Autotuning (AT)
RXnA	Unused		—	—
RXnB				
RXnC	Extended display completion		0: OFF	—
RXnD	Extended setting completion		1: ON	—
RXnE	Unused		—	—
RXnF	Hardware error flag		0: OFF 1: ON Hardware error flag ON condition • Hardware error • RAM read/write error • Stack overflow • Memory backup error • Configuration error	—
RX(n+1)0 ⋮ RX(n+1)7	Reserved		—	—
RX(n+1)8	Initialize data processing request flag		0: OFF	—
RX(n+1)9	Initialize data setting completion flag		1: ON	—
RX(n+1)A	Error status flag		0: OFF 1: ON Error status flag ON condition • Communication error	—
RX(n+1)B	Remote ready		0: Not ready state 1: Ready state	—
RX(n+1)C ⋮ RX(n+1)F	Reserved		—	—

■ Remote output

Data direction: Master station (PLC) → COM-JC (Remote device station)

Data capacity: 32-bit

Address	Communication item		Data range	Factory set value
RYn0	Bit 0	Extension number for display	Display extension number are specified by the ON/OFF states of RYn0 to RYn5. Data 0: OFF 1: ON [Decimal number: 0 to 63]	0
RYn1	Bit 1			
RYn2	Bit 2			
RYn3	Bit 3			
RYn4	Bit 4			
RYn5	Bit 5			
RYn6	Bit 0	Extension number for setting	Setting extension number are specified by the ON/OFF states of RYn6 to RYnB. Data 0: OFF 1: ON [Decimal number: 0 to 63]	0
RYn7	Bit 1			
RYn8	Bit 2			
RYn9	Bit 3			
RYnA	Bit 4			
RYnB	Bit 5			
RYnC	Extended display flag		0: OFF	0
RYnD	Extended setting flag (Setting update flag)		1: ON	0
RYnE	Unused		—	—
RYnF	RUN/STOP transfer		Logic of RUN/STOP transfer is different by model code. For COM-JC*02-1 0: RUN (Control start) 1: STOP (Control stop) For COM-JC*02-2 0: STOP (Control stop) 1: RUN (Control start)	0
RY(n+1)0 ⋮ RY(n+1)7	Reserved		—	—
RY(n+1)8	Initialize data processing completion flag		0: OFF	0
RY(n+1)9	Initialize data setting request flag		1: ON	0
RY(n+1)A	Error reset request flag			0
RY(n+1)B ⋮ RY(n+1)F	Reserved		—	—

7.1.2 4 stations occupied 1 time

■ Remote input

Data direction: COM-JC (Remote device station) → Master station (PLC)

Data capacity: 128-bit

Address	Communication item		Data range	Factory set value
RXn0	CH1	Event 1 state	0: OFF 1: ON	—
RXn1		Event 2 state		—
RXn2		Burnout state		—
RXn3		Heater break alarm (HBA) state		—
RXn4		PID/AT transfer		0: PID control 1: Autotuning (AT)
RXn5	CH2	Event 1 state	0: OFF 1: ON	—
RXn6		Event 2 state		—
RXn7		Burnout state		—
RXn8		Heater break alarm (HBA) state		—
RXn9		PID/AT transfer		0: PID control 1: Autotuning (AT)
RXnA	Unused		—	—
RXnB				
RXnC	Extended display completion		0: OFF	—
RXnD	Extended setting completion		1: ON	—
RXnE	Unused		—	—
RXnF	Hardware error flag		0: OFF 1: ON Hardware error flag ON condition • Hardware error • RAM read/write error • Stack overflow • Memory backup error • Configuration error	—
RX(n+1)0 ⋮ RX(n+1)F	Unused		—	—
RX(n+2)0	CH3	Event 1 state	0: OFF 1: ON	—
RX(n+2)1		Event 2 state		—
RX(n+2)2		Burnout state		—
RX(n+2)3		Heater break alarm (HBA) state		—
RX(n+2)4		PID/AT transfer		0: PID control 1: Autotuning (AT)
RX(n+2)5	CH4	Event 1 state	0: OFF 1: ON	—
RX(n+2)6		Event 2 state		—
RX(n+2)7		Burnout state		—
RX(n+2)8		Heater break alarm (HBA) state		—
RX(n+2)9		PID/AT transfer		0: PID control 1: Autotuning (AT)
RX(n+2)A	CH5	Event 1 state	0: OFF 1: ON	—
RX(n+2)B		Event 2 state		—
RX(n+2)C		Burnout state		—
RX(n+2)D		Heater break alarm (HBA) state		—
RX(n+2)E		PID/AT transfer		0: PID control 1: Autotuning (AT)

Continued on the next page.

Continued from the previous page.

Address	Communication item		Data range	Factory set value
RX(n+2)F	CH6	Event 1 state	0: OFF 1: ON	—
RX(n+3)0		Event 2 state		—
RX(n+3)1		Burnout state		—
RX(n+3)2		Heater break alarm (HBA) state		—
RX(n+3)3		PID/AT transfer		0: PID control 1: Autotuning (AT)
RX(n+3)4	CH7	Event 1 state	0: OFF 1: ON	—
RX(n+3)5		Event 2 state		—
RX(n+3)6		Burnout state		—
RX(n+3)7		Heater break alarm (HBA) state		—
RX(n+3)8		PID/AT transfer		0: PID control 1: Autotuning (AT)
RX(n+3)9	CH8	Event 1 state	0: OFF 1: ON	—
RX(n+3)A		Event 2 state		—
RX(n+3)B		Burnout state		—
RX(n+3)C		Heater break alarm (HBA) state		—
RX(n+3)D		PID/AT transfer		0: PID control 1: Autotuning (AT)
RX(n+3)E	Unused		—	—
RX(n+3)F				
RX(n+4)0	CH9	Event 1 state	0: OFF 1: ON	—
RX(n+4)1		Event 2 state		—
RX(n+4)2		Burnout state		—
RX(n+4)3		Heater break alarm (HBA) state		—
RX(n+4)4		PID/AT transfer		0: PID control 1: Autotuning (AT)
RX(n+4)5	CH10	Event 1 state	0: OFF 1: ON	—
RX(n+4)6		Event 2 state		—
RX(n+4)7		Burnout state		—
RX(n+4)8		Heater break alarm (HBA) state		—
RX(n+4)9		PID/AT transfer		0: PID control 1: Autotuning (AT)
RX(n+4)A	CH11	Event 1 state	0: OFF 1: ON	—
RX(n+4)B		Event 2 state		—
RX(n+4)C		Burnout state		—
RX(n+4)D		Heater break alarm (HBA) state		—
RX(n+4)E		PID/AT transfer		0: PID control 1: Autotuning (AT)
RX(n+4)F	CH12	Event 1 state	0: OFF 1: ON	—
RX(n+5)0		Event 2 state		—
RX(n+5)1		Burnout state		—
RX(n+5)2		Heater break alarm (HBA) state		—
RX(n+5)3		PID/AT transfer		0: PID control 1: Autotuning (AT)
RX(n+5)4	CH13	Event 1 state	0: OFF 1: ON	—
RX(n+5)5		Event 2 state		—
RX(n+5)6		Burnout state		—
RX(n+5)7		Heater break alarm (HBA) state		—
RX(n+5)8		PID/AT transfer		0: PID control 1: Autotuning (AT)

Continued on the next page.

Continued from the previous page.

Address	Communication item		Data range	Factory set value
RX(n+5)9	CH14	Event 1 state	0: OFF 1: ON	—
RX(n+5)A		Event 2 state		—
RX(n+5)B		Burnout state		—
RX(n+5)C		Heater break alarm (HBA) state		—
RX(n+5)D		PID/AT transfer		0: PID control 1: Autotuning (AT)
RX(n+5)E	Unused		—	—
RX(n+5)F				
RX(n+6)0	CH15	Event 1 state	0: OFF 1: ON	—
RX(n+6)1		Event 2 state		—
RX(n+6)2		Burnout state		—
RX(n+6)3		Heater break alarm (HBA) state		—
RX(n+6)4		PID/AT transfer		0: PID control 1: Autotuning (AT)
RX(n+6)5	CH16	Event 1 state	0: OFF 1: ON	—
RX(n+6)6		Event 2 state		—
RX(n+6)7		Burnout state		—
RX(n+6)8		Heater break alarm (HBA) state		—
RX(n+6)9		PID/AT transfer		0: PID control 1: Autotuning (AT)
RX(n+6)A ⋮ RX(n+6)F	Unused		—	—
RX(n+7)0 ⋮ RX(n+7)7	Reserved		—	—
RX(n+7)8	Initialize data processing request flag		0: OFF 1: ON	—
RX(n+7)9	Initialize data setting completion flag			—
RX(n+7)A	Error status flag		0: OFF 1: ON Error status flag ON condition • Communication error	—
RX(n+7)B	Remote ready		0: Not ready state 1: Ready state	—
RX(n+7)C ⋮ RX(n+7)F	Reserved		—	—

■ Remote output

Data direction: Master station (PLC) → COM-JC (Remote device station)

Data capacity: 128-bit

Address	Communication item		Data range	Factory set value
RYn0	Bit 0	Extension number for display	Display extension number are specified by the ON/OFF states of RYn0 to RYn5 and RY(n+1)0 to RY(n+1)2. Data 0: OFF 1: ON [Decimal number: 0 to 511]	0
RYn1	Bit 1			
RYn2	Bit 2			
RYn3	Bit 3			
RYn4	Bit 4			
RYn5	Bit 5			
RYn6	Bit 0	Extension number for setting	Setting extension number are specified by the ON/OFF states of RYn6 to RYnB and RY(n+1)8 to RY(n+1)A. Data 0: OFF 1: ON [Decimal number: 0 to 511]	0
RYn7	Bit 1			
RYn8	Bit 2			
RYn9	Bit 3			
RYnA	Bit 4			
RYnB	Bit 5			
RYnC	Extended display flag		0: OFF 1: ON	0
RYnD	Extended setting flag (Setting update flag)		0: OFF 1: ON	0
RYnE	Unused		—	—
RYnF	RUN/STOP transfer		Logic of RUN/STOP transfer is different by model code. For COM-JC*02-1 0: RUN (Control start) 1: STOP (Control stop) For COM-JC*02-2 0: STOP (Control stop) 1: RUN (Control start)	0
RY(n+1)0	Bit 6	Extension number for display Bit 9 to Bit 13: Unused	Display extension number are specified by the ON/OFF states of RYn0 to RYn5 and RY(n+1)0 to RY(n+1)2. Data 0: OFF 1: ON [Decimal number: 0 to 511]	0
RY(n+1)1	Bit 7			
RY(n+1)2	Bit 8			
RY(n+1)3	Bit 9			
RY(n+1)4	Bit 10			
RY(n+1)5	Bit 11			
RY(n+1)6	Bit 12			
RY(n+1)7	Bit 13			
RY(n+1)8	Bit 6	Extension number for setting Bit 9 to Bit 13: Unused	Setting extension number are specified by the ON/OFF states of RYn6 to RYnB and RY(n+1)8 to RY(n+1)A. Data 0: OFF 1: ON [Decimal number: 0 to 511]	0
RY(n+1)9	Bit 7			
RY(n+1)A	Bit 8			
RY(n+1)B	Bit 9			
RY(n+1)C	Bit 10			
RY(n+1)D	Bit 11			
RY(n+1)E	Bit 12			
RY(n+1)F	Bit 13			

Continued on the next page.

7. COMMUNICATION DATA LIST

Continued from the previous page.

Address	Communication item		Data range	Factory set value
RY(n+2)0	Bit 0	Area number for display Bit 4 to Bit 7: Unused	Display area number are specified by the ON/OFF states of RY(n+2)0 to RY(n+2)3. Data 0: OFF 1: ON [Decimal number: 0 to 16] (0, 9 to 16: Control area)	0
RY(n+2)1	Bit 1			
RY(n+2)2	Bit 2			
RY(n+2)3	Bit 3			
RY(n+2)4	Bit 4			
RY(n+2)5	Bit 5			
RY(n+2)6	Bit 6			
RY(n+2)7	Bit 7			
RY(n+2)8	Bit 0	Area number for setting Bit 4 to Bit 7: Unused	Setting area number are specified by the ON/OFF states of RY(n+2)8 to RY(n+2)B. Data 0: OFF 1: ON [Decimal number: 0 to 16] (0, 9 to 16: Control area)	0
RY(n+2)9	Bit 1			
RY(n+2)A	Bit 2			
RY(n+2)B	Bit 3			
RY(n+2)C	Bit 4			
RY(n+2)D	Bit 5			
RY(n+2)E	Bit 6			
RY(n+2)F	Bit 7			
RY(n+3)0 ⋮ RY(n+6)F	Unused		—	—
RY(n+7)0 ⋮ RY(n+7)7	Reserved		—	—
RY(n+7)8	Initialize data processing completion flag		0: OFF 1: ON	0
RY(n+7)9	Initialize data setting request flag			0
RY(n+7)A	Error reset request flag			0
RY(n+7)B ⋮ RY(n+7)F	Reserved		—	—

7.1.3 4 stations occupied 2 times

■ Remote input

Data direction: COM-JC (Remote device station) → Master station (PLC)

Data capacity: 224-bit

Address	Communication item		Data range	Factory set value
RXn0	CH1	Event 1 state	0: OFF 1: ON	—
RXn1		Event 2 state		—
RXn2		Burnout state		—
RXn3		Heater break alarm (HBA) state		—
RXn4		PID/AT transfer		0: PID control 1: Autotuning (AT)
RXn5	CH2	Event 1 state	0: OFF 1: ON	—
RXn6		Event 2 state		—
RXn7		Burnout state		—
RXn8		Heater break alarm (HBA) state		—
RXn9		PID/AT transfer		0: PID control 1: Autotuning (AT)
RXnA	Unused		—	—
RXnB				
RXnC	Extended display completion		0: OFF 1: ON	—
RXnD	Extended setting completion			—
RXnE	Unused		—	—
RXnF	Hardware error flag		0: OFF 1: ON Hardware error flag ON condition • Hardware error • RAM read/write error • Stack overflow • Memory backup error • Configuration error	—
RX(n+1)0 ⋮ RX(n+1)F	Unused		—	—
RX(n+2)0	CH3	Event 1 state	0: OFF 1: ON	—
RX(n+2)1		Event 2 state		—
RX(n+2)2		Burnout state		—
RX(n+2)3		Heater break alarm (HBA) state		—
RX(n+2)4		PID/AT transfer		0: PID control 1: Autotuning (AT)
RX(n+2)5	CH4	Event 1 state	0: OFF 1: ON	—
RX(n+2)6		Event 2 state		—
RX(n+2)7		Burnout state		—
RX(n+2)8		Heater break alarm (HBA) state		—
RX(n+2)9		PID/AT transfer		0: PID control 1: Autotuning (AT)
RX(n+2)A	CH5	Event 1 state	0: OFF 1: ON	—
RX(n+2)B		Event 2 state		—
RX(n+2)C		Burnout state		—
RX(n+2)D		Heater break alarm (HBA) state		—
RX(n+2)E		PID/AT transfer		0: PID control 1: Autotuning (AT)

Continued on the next page.

7. COMMUNICATION DATA LIST

Continued from the previous page.

Address	Communication item		Data range	Factory set value
RX(n+2)F	CH6	Event 1 state	0: OFF 1: ON	—
RX(n+3)0		Event 2 state		—
RX(n+3)1		Burnout state		—
RX(n+3)2		Heater break alarm (HBA) state		—
RX(n+3)3		PID/AT transfer		0: PID control 1: Autotuning (AT)
RX(n+3)4	CH7	Event 1 state	0: OFF 1: ON	—
RX(n+3)5		Event 2 state		—
RX(n+3)6		Burnout state		—
RX(n+3)7		Heater break alarm (HBA) state		—
RX(n+3)8		PID/AT transfer		0: PID control 1: Autotuning (AT)
RX(n+3)9	CH8	Event 1 state	0: OFF 1: ON	—
RX(n+3)A		Event 2 state		—
RX(n+3)B		Burnout state		—
RX(n+3)C		Heater break alarm (HBA) state		—
RX(n+3)D		PID/AT transfer		0: PID control 1: Autotuning (AT)
RX(n+3)E	Unused		—	—
RX(n+3)F				
RX(n+4)0	CH9	Event 1 state	0: OFF 1: ON	—
RX(n+4)1		Event 2 state		—
RX(n+4)2		Burnout state		—
RX(n+4)3		Heater break alarm (HBA) state		—
RX(n+4)4		PID/AT transfer		0: PID control 1: Autotuning (AT)
RX(n+4)5	CH10	Event 1 state	0: OFF 1: ON	—
RX(n+4)6		Event 2 state		—
RX(n+4)7		Burnout state		—
RX(n+4)8		Heater break alarm (HBA) state		—
RX(n+4)9		PID/AT transfer		0: PID control 1: Autotuning (AT)
RX(n+4)A	CH11	Event 1 state	0: OFF 1: ON	—
RX(n+4)B		Event 2 state		—
RX(n+4)C		Burnout state		—
RX(n+4)D		Heater break alarm (HBA) state		—
RX(n+4)E		PID/AT transfer		0: PID control 1: Autotuning (AT)
RX(n+4)F	CH12	Event 1 state	0: OFF 1: ON	—
RX(n+5)0		Event 2 state		—
RX(n+5)1		Burnout state		—
RX(n+5)2		Heater break alarm (HBA) state		—
RX(n+5)3		PID/AT transfer		0: PID control 1: Autotuning (AT)
RX(n+5)4	CH13	Event 1 state	0: OFF 1: ON	—
RX(n+5)5		Event 2 state		—
RX(n+5)6		Burnout state		—
RX(n+5)7		Heater break alarm (HBA) state		—
RX(n+5)8		PID/AT transfer		0: PID control 1: Autotuning (AT)

Continued on the next page.

Continued from the previous page.

Address	Communication item		Data range	Factory set value
RX(n+5)9	CH14	Event 1 state	0: OFF 1: ON	—
RX(n+5)A		Event 2 state		—
RX(n+5)B		Burnout state		—
RX(n+5)C		Heater break alarm (HBA) state		—
RX(n+5)D		PID/AT transfer		0: PID control 1: Autotuning (AT)
RX(n+5)E	Unused		—	—
RX(n+5)F				
RX(n+6)0	CH15	Event 1 state	0: OFF 1: ON	—
RX(n+6)1		Event 2 state		—
RX(n+6)2		Burnout state		—
RX(n+6)3		Heater break alarm (HBA) state		—
RX(n+6)4		PID/AT transfer		0: PID control 1: Autotuning (AT)
RX(n+6)5	CH16	Event 1 state	0: OFF 1: ON	—
RX(n+6)6		Event 2 state		—
RX(n+6)7		Burnout state		—
RX(n+6)8		Heater break alarm (HBA) state		—
RX(n+6)9		PID/AT transfer		0: PID control 1: Autotuning (AT)
RX(n+6)A	Unused		—	—
⋮				
RX(n+6)F				
RX(n+7)0	CH17	Event 1 state	0: OFF 1: ON	—
RX(n+7)1		Event 2 state		—
RX(n+7)2		Burnout state		—
RX(n+7)3		Heater break alarm (HBA) state		—
RX(n+7)4		PID/AT transfer		0: PID control 1: Autotuning (AT)
RX(n+7)5	CH18	Event 1 state	0: OFF 1: ON	—
RX(n+7)6		Event 2 state		—
RX(n+7)7		Burnout state		—
RX(n+7)8		Heater break alarm (HBA) state		—
RX(n+7)9		PID/AT transfer		0: PID control 1: Autotuning (AT)
RX(n+7)A	CH19	Event 1 state	0: OFF 1: ON	—
RX(n+7)B		Event 2 state		—
RX(n+7)C		Burnout state		—
RX(n+7)D		Heater break alarm (HBA) state		—
RX(n+7)E		PID/AT transfer		0: PID control 1: Autotuning (AT)
RX(n+7)F	Unused		—	—
RX(n+8)0	CH20	Event 1 state	0: OFF 1: ON	—
RX(n+8)1		Event 2 state		—
RX(n+8)2		Burnout state		—
RX(n+8)3		Heater break alarm (HBA) state		—
RX(n+8)4		PID/AT transfer		0: PID control 1: Autotuning (AT)

Continued on the next page.

7. COMMUNICATION DATA LIST

Continued from the previous page.

Address	Communication item		Data range	Factory set value
RX(n+8)5	CH21	Event 1 state	0: OFF 1: ON	—
RX(n+8)6		Event 2 state		—
RX(n+8)7		Burnout state		—
RX(n+8)8		Heater break alarm (HBA) state		—
RX(n+8)9		PID/AT transfer		0: PID control 1: Autotuning (AT)
RX(n+8)A	CH22	Event 1 state	0: OFF 1: ON	—
RX(n+8)B		Event 2 state		—
RX(n+8)C		Burnout state		—
RX(n+8)D		Heater break alarm (HBA) state		—
RX(n+8)E		PID/AT transfer		0: PID control 1: Autotuning (AT)
RX(n+8)F	Unused		—	—
RX(n+9)0	CH23	Event 1 state	0: OFF 1: ON	—
RX(n+9)1		Event 2 state		—
RX(n+9)2		Burnout state		—
RX(n+9)3		Heater break alarm (HBA) state		—
RX(n+9)4		PID/AT transfer		0: PID control 1: Autotuning (AT)
RX(n+9)5	CH24	Event 1 state	0: OFF 1: ON	—
RX(n+9)6		Event 2 state		—
RX(n+9)7		Burnout state		—
RX(n+9)8		Heater break alarm (HBA) state		—
RX(n+9)9		PID/AT transfer		0: PID control 1: Autotuning (AT)
RX(n+9)A	CH25	Event 1 state	0: OFF 1: ON	—
RX(n+9)B		Event 2 state		—
RX(n+9)C		Burnout state		—
RX(n+9)D		Heater break alarm (HBA) state		—
RX(n+9)E		PID/AT transfer		0: PID control 1: Autotuning (AT)
RX(n+9)F	Unused		—	—
RX(n+A)0	CH26	Event 1 state	0: OFF 1: ON	—
RX(n+A)1		Event 2 state		—
RX(n+A)2		Burnout state		—
RX(n+A)3		Heater break alarm (HBA) state		—
RX(n+A)4		PID/AT transfer		0: PID control 1: Autotuning (AT)
RX(n+A)5	CH27	Event 1 state	0: OFF 1: ON	—
RX(n+A)6		Event 2 state		—
RX(n+A)7		Burnout state		—
RX(n+A)8		Heater break alarm (HBA) state		—
RX(n+A)9		PID/AT transfer		0: PID control 1: Autotuning (AT)

Continued on the next page.

Continued from the previous page.

Address	Communication item		Data range	Factory set value
RX(n+A)A	CH28	Event 1 state	0: OFF 1: ON	—
RX(n+A)B		Event 2 state		—
RX(n+A)C		Burnout state		—
RX(n+A)D		Heater break alarm (HBA) state		—
RX(n+A)E		PID/AT transfer		0: PID control 1: Autotuning (AT)
RX(n+A)F	Unused		—	—
RX(n+B)0	CH29	Event 1 state	0: OFF 1: ON	—
RX(n+B)1		Event 2 state		—
RX(n+B)2		Burnout state		—
RX(n+B)3		Heater break alarm (HBA) state		—
RX(n+B)4		PID/AT transfer		0: PID control 1: Autotuning (AT)
RX(n+B)5	CH30	Event 1 state	0: OFF 1: ON	—
RX(n+B)6		Event 2 state		—
RX(n+B)7		Burnout state		—
RX(n+B)8		Heater break alarm (HBA) state		—
RX(n+B)9		PID/AT transfer		0: PID control 1: Autotuning (AT)
RX(n+B)A	CH31	Event 1 state	0: OFF 1: ON	—
RX(n+B)B		Event 2 state		—
RX(n+B)C		Burnout state		—
RX(n+B)D		Heater break alarm (HBA) state		—
RX(n+B)E		PID/AT transfer		0: PID control 1: Autotuning (AT)
RX(n+B)F	Unused		—	—
RX(n+C)0	CH32	Event 1 state	0: OFF 1: ON	—
RX(n+C)1		Event 2 state		—
RX(n+C)2		Burnout state		—
RX(n+C)3		Heater break alarm (HBA) state		—
RX(n+C)4		PID/AT transfer		0: PID control 1: Autotuning (AT)
RX(n+C)5 ⋮ RX(n+C)F	Unused		—	—
RX(n+D)0 ⋮ RX(n+D)7	Reserved		—	—
RX(n+D)8	Initialize data processing request flag		0: OFF 1: ON	—
RX(n+D)9	Initialize data setting completion flag			—
RX(n+D)A	Error status flag		0: OFF 1: ON Error status flag ON condition • Communication error	—
RX(n+D)B	Remote ready		0: Not ready state 1: Ready state	—
RX(n+D)C ⋮ RX(n+D)F	Reserved		—	—

■ Remote output

Data direction: Master station (PLC) → COM-JC (Remote device station)

Data capacity: 224-bit

Address	Communication item		Data range	Factory set value
RYn0	Bit 0	Extension number for display	Display extension number are specified by the ON/OFF states of RYn0 to RYn5 and RY(n+1)0 to RY(n+1)2. Data 0: OFF 1: ON [Decimal number: 0 to 511]	0
RYn1	Bit 1			
RYn2	Bit 2			
RYn3	Bit 3			
RYn4	Bit 4			
RYn5	Bit 5			
RYn6	Bit 0	Extension number for setting	Setting extension number are specified by the ON/OFF states of RYn6 to RYnB and RY(n+1)8 to RY(n+1)A. Data 0: OFF 1: ON [Decimal number: 0 to 511]	0
RYn7	Bit 1			
RYn8	Bit 2			
RYn9	Bit 3			
RYnA	Bit 4			
RYnB	Bit 5			
RYnC	Extended display flag		0: OFF 1: ON	0
RYnD	Extended setting flag (Setting update flag)		0: OFF 1: ON	0
RYnE	Unused		—	—
RYnF	RUN/STOP transfer		Logic of RUN/STOP transfer is different by model code. For COM-JC*02-1 0: RUN (Control start) 1: STOP (Control stop) For COM-JC*02-2 0: STOP (Control stop) 1: RUN (Control start)	0
RY(n+1)0	Bit 6	Extension number for display Bit 9 to Bit 13: Unused	Display extension number are specified by the ON/OFF states of RYn0 to RYn5 and RY(n+1)0 to RY(n+1)2. Data 0: OFF 1: ON [Decimal number: 0 to 511]	0
RY(n+1)1	Bit 7			
RY(n+1)2	Bit 8			
RY(n+1)3	Bit 9			
RY(n+1)4	Bit 10			
RY(n+1)5	Bit 11			
RY(n+1)6	Bit 12			
RY(n+1)7	Bit 13			
RY(n+1)8	Bit 6	Extension number for setting Bit 9 to Bit 13: Unused	Setting extension number are specified by the ON/OFF states of RYn6 to RYnB and RY(n+1)8 to RY(n+1)A. Data 0: OFF 1: ON [Decimal number: 0 to 511]	0
RY(n+1)9	Bit 7			
RY(n+1)A	Bit 8			
RY(n+1)B	Bit 9			
RY(n+1)C	Bit 10			
RY(n+1)D	Bit 11			
RY(n+1)E	Bit 12			
RY(n+1)F	Bit 13			

Continued on the next page.

Continued from the previous page.

Address	Communication item		Data range	Factory set value
RY(n+2)0	Bit 0	Area number for display Bit 4 to Bit 7: Unused	Display area number are specified by the ON/OFF states of RY(n+2)0 to RY(n+2)3. Data 0: OFF 1: ON [Decimal number: 0 to 16] (0, 9 to 16: Control area)	0
RY(n+2)1	Bit 1			
RY(n+2)2	Bit 2			
RY(n+2)3	Bit 3			
RY(n+2)4	Bit 4			
RY(n+2)5	Bit 5			
RY(n+2)6	Bit 6			
RY(n+2)7	Bit 7			
RY(n+2)8	Bit 0	Area number for setting Bit 4 to Bit 7: Unused	Setting area number are specified by the ON/OFF states of RY(n+2)8 to RY(n+2)B. Data 0: OFF 1: ON [Decimal number: 0 to 16] (0, 9 to 16: Control area)	0
RY(n+2)9	Bit 1			
RY(n+2)A	Bit 2			
RY(n+2)B	Bit 3			
RY(n+2)C	Bit 4			
RY(n+2)D	Bit 5			
RY(n+2)E	Bit 6			
RY(n+2)F	Bit 7			
RY(n+3)0 ⋮ RY(n+C)F	Unused		—	—
RY(n+D)0 ⋮ RY(n+D)7	Reserved		—	—
RY(n+D)8	Initialize data processing completion flag		0: OFF 1: ON	0
RY(n+D)9	Initialize data setting request flag		0: OFF 1: ON	0
RY(n+D)A	Error reset request flag		0: OFF 1: ON	0
RY(n+D)B ⋮ RY(n+D)F	Reserved		—	—

7.1.4 4 stations occupied 4 times

■ Remote input

Data direction: COM-JC (Remote device station) → Master station (PLC)

Data capacity: 448-bit

Address	Communication item		Data range	Factory set value
RXn0	CH1	Event 1 state	0: OFF 1: ON	—
RXn1		Event 2 state		—
RXn2		Burnout state		—
RXn3		Heater break alarm (HBA) state		—
RXn4		PID/AT transfer		0: PID control 1: Autotuning (AT)
RXn5	CH2	Event 1 state	0: OFF 1: ON	—
RXn6		Event 2 state		—
RXn7		Burnout state		—
RXn8		Heater break alarm (HBA) state		—
RXn9		PID/AT transfer		0: PID control 1: Autotuning (AT)
RXnA	Unused		—	—
RXnB	Unused		—	—
RXnC	Extended display completion		0: OFF	—
RXnD	Extended setting completion		1: ON	—
RXnE	Unused		—	—
RXnF	Hardware error flag		0: OFF 1: ON Hardware error flag ON condition • Hardware error • RAM read/write error • Stack overflow • Memory backup error • Configuration error	—
RX(n+1)0 ⋮ RX(n+1)F	Unused		—	—
RX(n+2)0	CH3	Event 1 state	0: OFF 1: ON	—
RX(n+2)1		Event 2 state		—
RX(n+2)2		Burnout state		—
RX(n+2)3		Heater break alarm (HBA) state		—
RX(n+2)4		PID/AT transfer		0: PID control 1: Autotuning (AT)
RX(n+2)5	CH4	Event 1 state	0: OFF 1: ON	—
RX(n+2)6		Event 2 state		—
RX(n+2)7		Burnout state		—
RX(n+2)8		Heater break alarm (HBA) state		—
RX(n+2)9		PID/AT transfer		0: PID control 1: Autotuning (AT)
RX(n+2)A	CH5	Event 1 state	0: OFF 1: ON	—
RX(n+2)B		Event 2 state		—
RX(n+2)C		Burnout state		—
RX(n+2)D		Heater break alarm (HBA) state		—
RX(n+2)E		PID/AT transfer		0: PID control 1: Autotuning (AT)

Continued on the next page.

Continued from the previous page.

Address	Communication item		Data range	Factory set value
RX(n+2)F	CH6	Event 1 state	0: OFF 1: ON	—
RX(n+3)0		Event 2 state		—
RX(n+3)1		Burnout state		—
RX(n+3)2		Heater break alarm (HBA) state		—
RX(n+3)3		PID/AT transfer		0: PID control 1: Autotuning (AT)
RX(n+3)4	CH7	Event 1 state	0: OFF 1: ON	—
RX(n+3)5		Event 2 state		—
RX(n+3)6		Burnout state		—
RX(n+3)7		Heater break alarm (HBA) state		—
RX(n+3)8		PID/AT transfer		0: PID control 1: Autotuning (AT)
RX(n+3)9	CH8	Event 1 state	0: OFF 1: ON	—
RX(n+3)A		Event 2 state		—
RX(n+3)B		Burnout state		—
RX(n+3)C		Heater break alarm (HBA) state		—
RX(n+3)D		PID/AT transfer		0: PID control 1: Autotuning (AT)
RX(n+3)E	Unused		—	—
RX(n+3)F				
RX(n+4)0	CH9	Event 1 state	0: OFF 1: ON	—
RX(n+4)1		Event 2 state		—
RX(n+4)2		Burnout state		—
RX(n+4)3		Heater break alarm (HBA) state		—
RX(n+4)4		PID/AT transfer		0: PID control 1: Autotuning (AT)
RX(n+4)5	CH10	Event 1 state	0: OFF 1: ON	—
RX(n+4)6		Event 2 state		—
RX(n+4)7		Burnout state		—
RX(n+4)8		Heater break alarm (HBA) state		—
RX(n+4)9		PID/AT transfer		0: PID control 1: Autotuning (AT)
RX(n+4)A	CH11	Event 1 state	0: OFF 1: ON	—
RX(n+4)B		Event 2 state		—
RX(n+4)C		Burnout state		—
RX(n+4)D		Heater break alarm (HBA) state		—
RX(n+4)E		PID/AT transfer		0: PID control 1: Autotuning (AT)
RX(n+4)F	CH12	Event 1 state	0: OFF 1: ON	—
RX(n+5)0		Event 2 state		—
RX(n+5)1		Burnout state		—
RX(n+5)2		Heater break alarm (HBA) state		—
RX(n+5)3		PID/AT transfer		0: PID control 1: Autotuning (AT)
RX(n+5)4	CH13	Event 1 state	0: OFF 1: ON	—
RX(n+5)5		Event 2 state		—
RX(n+5)6		Burnout state		—
RX(n+5)7		Heater break alarm (HBA) state		—
RX(n+5)8		PID/AT transfer		0: PID control 1: Autotuning (AT)

Continued on the next page.

7. COMMUNICATION DATA LIST

Continued from the previous page.

Address	Communication item		Data range	Factory set value
RX(n+5)9	CH14	Event 1 state	0: OFF 1: ON	—
RX(n+5)A		Event 2 state		—
RX(n+5)B		Burnout state		—
RX(n+5)C		Heater break alarm (HBA) state		—
RX(n+5)D		PID/AT transfer		0: PID control 1: Autotuning (AT)
RX(n+5)E	Unused		—	—
RX(n+5)F				
RX(n+6)0	CH15	Event 1 state	0: OFF 1: ON	—
RX(n+6)1		Event 2 state		—
RX(n+6)2		Burnout state		—
RX(n+6)3		Heater break alarm (HBA) state		—
RX(n+6)4		PID/AT transfer		0: PID control 1: Autotuning (AT)
RX(n+6)5	CH16	Event 1 state	0: OFF 1: ON	—
RX(n+6)6		Event 2 state		—
RX(n+6)7		Burnout state		—
RX(n+6)8		Heater break alarm (HBA) state		—
RX(n+6)9		PID/AT transfer		0: PID control 1: Autotuning (AT)
RX(n+6)A	Unused		—	—
⋮				
RX(n+6)F				
RX(n+7)0	CH17	Event 1 state	0: OFF 1: ON	—
RX(n+7)1		Event 2 state		—
RX(n+7)2		Burnout state		—
RX(n+7)3		Heater break alarm (HBA) state		—
RX(n+7)4		PID/AT transfer		0: PID control 1: Autotuning (AT)
RX(n+7)5	CH18	Event 1 state	0: OFF 1: ON	—
RX(n+7)6		Event 2 state		—
RX(n+7)7		Burnout state		—
RX(n+7)8		Heater break alarm (HBA) state		—
RX(n+7)9		PID/AT transfer		0: PID control 1: Autotuning (AT)
RX(n+7)A	CH19	Event 1 state	0: OFF 1: ON	—
RX(n+7)B		Event 2 state		—
RX(n+7)C		Burnout state		—
RX(n+7)D		Heater break alarm (HBA) state		—
RX(n+7)E		PID/AT transfer		0: PID control 1: Autotuning (AT)
RX(n+7)F	Unused		—	—
RX(n+8)0	CH20	Event 1 state	0: OFF 1: ON	—
RX(n+8)1		Event 2 state		—
RX(n+8)2		Burnout state		—
RX(n+8)3		Heater break alarm (HBA) state		—
RX(n+8)4		PID/AT transfer		0: PID control 1: Autotuning (AT)

Continued on the next page.

Continued from the previous page.

Address	Communication item		Data range	Factory set value
RX(n+8)5	CH21	Event 1 state	0: OFF 1: ON	—
RX(n+8)6		Event 2 state		—
RX(n+8)7		Burnout state		—
RX(n+8)8		Heater break alarm (HBA) state		—
RX(n+8)9		PID/AT transfer		0: PID control 1: Autotuning (AT)
RX(n+8)A	CH22	Event 1 state	0: OFF 1: ON	—
RX(n+8)B		Event 2 state		—
RX(n+8)C		Burnout state		—
RX(n+8)D		Heater break alarm (HBA) state		—
RX(n+8)E		PID/AT transfer		0: PID control 1: Autotuning (AT)
RX(n+8)F	Unused		—	—
RX(n+9)0	CH23	Event 1 state	0: OFF 1: ON	—
RX(n+9)1		Event 2 state		—
RX(n+9)2		Burnout state		—
RX(n+9)3		Heater break alarm (HBA) state		—
RX(n+9)4		PID/AT transfer		0: PID control 1: Autotuning (AT)
RX(n+9)5	CH24	Event 1 state	0: OFF 1: ON	—
RX(n+9)6		Event 2 state		—
RX(n+9)7		Burnout state		—
RX(n+9)8		Heater break alarm (HBA) state		—
RX(n+9)9		PID/AT transfer		0: PID control 1: Autotuning (AT)
RX(n+9)A	CH25	Event 1 state	0: OFF 1: ON	—
RX(n+9)B		Event 2 state		—
RX(n+9)C		Burnout state		—
RX(n+9)D		Heater break alarm (HBA) state		—
RX(n+9)E		PID/AT transfer		0: PID control 1: Autotuning (AT)
RX(n+9)F	Unused		—	—
RX(n+A)0	CH26	Event 1 state	0: OFF 1: ON	—
RX(n+A)1		Event 2 state		—
RX(n+A)2		Burnout state		—
RX(n+A)3		Heater break alarm (HBA) state		—
RX(n+A)4		PID/AT transfer		0: PID control 1: Autotuning (AT)
RX(n+A)5	CH27	Event 1 state	0: OFF 1: ON	—
RX(n+A)6		Event 2 state		—
RX(n+A)7		Burnout state		—
RX(n+A)8		Heater break alarm (HBA) state		—
RX(n+A)9		PID/AT transfer		0: PID control 1: Autotuning (AT)
RX(n+A)A	CH28	Event 1 state	0: OFF 1: ON	—
RX(n+A)B		Event 2 state		—
RX(n+A)C		Burnout state		—
RX(n+A)D		Heater break alarm (HBA) state		—
RX(n+A)E		PID/AT transfer		0: PID control 1: Autotuning (AT)

Continued on the next page.

7. COMMUNICATION DATA LIST

Continued from the previous page.

Address	Communication item	Data range	Factory set value
RX(n+A)F	Unused	—	—
RX(n+B)0	CH29	Event 1 state	0: OFF 1: ON
RX(n+B)1		Event 2 state	
RX(n+B)2		Burnout state	
RX(n+B)3		Heater break alarm (HBA) state	
RX(n+B)4		PID/AT transfer	
RX(n+B)5	CH30	Event 1 state	0: OFF 1: ON
RX(n+B)6		Event 2 state	
RX(n+B)7		Burnout state	
RX(n+B)8		Heater break alarm (HBA) state	
RX(n+B)9		PID/AT transfer	
RX(n+B)A	CH31	Event 1 state	0: OFF 1: ON
RX(n+B)B		Event 2 state	
RX(n+B)C		Burnout state	
RX(n+B)D		Heater break alarm (HBA) state	
RX(n+B)E		PID/AT transfer	
RX(n+B)F	Unused	—	—
RX(n+C)0	CH32	Event 1 state	0: OFF 1: ON
RX(n+C)1		Event 2 state	
RX(n+C)2		Burnout state	
RX(n+C)3		Heater break alarm (HBA) state	
RX(n+C)4		PID/AT transfer	
RX(n+C)5	CH33	Event 1 state	0: OFF 1: ON
RX(n+C)6		Event 2 state	
RX(n+C)7		Burnout state	
RX(n+C)8		Heater break alarm (HBA) state	
RX(n+C)9		PID/AT transfer	
RX(n+C)A	CH34	Event 1 state	0: OFF 1: ON
RX(n+C)B		Event 2 state	
RX(n+C)C		Burnout state	
RX(n+C)D		Heater break alarm (HBA) state	
RX(n+C)E		PID/AT transfer	
RX(n+C)F	Unused	—	—
RX(n+D)0	CH35	Event 1 state	0: OFF 1: ON
RX(n+D)1		Event 2 state	
RX(n+D)2		Burnout state	
RX(n+D)3		Heater break alarm (HBA) state	
RX(n+D)4		PID/AT transfer	

Continued on the next page.

Continued from the previous page.

Address	Communication item		Data range	Factory set value
RX(n+D)5	CH36	Event 1 state	0: OFF 1: ON	—
RX(n+D)6		Event 2 state		—
RX(n+D)7		Burnout state		—
RX(n+D)8		Heater break alarm (HBA) state		—
RX(n+D)9		PID/AT transfer		0: PID control 1: Autotuning (AT)
RX(n+D)A	CH37	Event 1 state	0: OFF 1: ON	—
RX(n+D)B		Event 2 state		—
RX(n+D)C		Burnout state		—
RX(n+D)D		Heater break alarm (HBA) state		—
RX(n+D)E		PID/AT transfer		0: PID control 1: Autotuning (AT)
RX(n+D)F	Unused		—	—
RX(n+E)0	CH38	Event 1 state	0: OFF 1: ON	—
RX(n+E)1		Event 2 state		—
RX(n+E)2		Burnout state		—
RX(n+E)3		Heater break alarm (HBA) state		—
RX(n+E)4		PID/AT transfer		0: PID control 1: Autotuning (AT)
RX(n+E)5	CH39	Event 1 state	0: OFF 1: ON	—
RX(n+E)6		Event 2 state		—
RX(n+E)7		Burnout state		—
RX(n+E)8		Heater break alarm (HBA) state		—
RX(n+E)9		PID/AT transfer		0: PID control 1: Autotuning (AT)
RX(n+E)A	CH40	Event 1 state	0: OFF 1: ON	—
RX(n+E)B		Event 2 state		—
RX(n+E)C		Burnout state		—
RX(n+E)D		Heater break alarm (HBA) state		—
RX(n+E)E		PID/AT transfer		0: PID control 1: Autotuning (AT)
RX(n+E)F	Unused		—	—
RX(n+F)0	CH41	Event 1 state	0: OFF 1: ON	—
RX(n+F)1		Event 2 state		—
RX(n+F)2		Burnout state		—
RX(n+F)3		Heater break alarm (HBA) state		—
RX(n+F)4		PID/AT transfer		0: PID control 1: Autotuning (AT)
RX(n+F)5	CH42	Event 1 state	0: OFF 1: ON	—
RX(n+F)6		Event 2 state		—
RX(n+F)7		Burnout state		—
RX(n+F)8		Heater break alarm (HBA) state		—
RX(n+F)9		PID/AT transfer		0: PID control 1: Autotuning (AT)
RX(n+F)A	CH43	Event 1 state	0: OFF 1: ON	—
RX(n+F)B		Event 2 state		—
RX(n+F)C		Burnout state		—
RX(n+F)D		Heater break alarm (HBA) state		—
RX(n+F)E		PID/AT transfer		0: PID control 1: Autotuning (AT)

Continued on the next page.

7. COMMUNICATION DATA LIST

Continued from the previous page.

Address	Communication item	Data range	Factory set value
RX(n+F)F	Unused	—	—
RX(n+10)0	CH44	Event 1 state	0: OFF 1: ON
RX(n+10)1		Event 2 state	
RX(n+10)2		Burnout state	
RX(n+10)3		Heater break alarm (HBA) state	
RX(n+10)4		PID/AT transfer	
RX(n+10)5	CH45	Event 1 state	0: OFF 1: ON
RX(n+10)6		Event 2 state	
RX(n+10)7		Burnout state	
RX(n+10)8		Heater break alarm (HBA) state	
RX(n+10)9		PID/AT transfer	
RX(n+10)A	CH46	Event 1 state	0: OFF 1: ON
RX(n+10)B		Event 2 state	
RX(n+10)C		Burnout state	
RX(n+10)D		Heater break alarm (HBA) state	
RX(n+10)E		PID/AT transfer	
RX(n+10)F	Unused	—	—
RX(n+11)0	CH47	Event 1 state	0: OFF 1: ON
RX(n+11)1		Event 2 state	
RX(n+11)2		Burnout state	
RX(n+11)3		Heater break alarm (HBA) state	
RX(n+11)4		PID/AT transfer	
RX(n+11)5	CH48	Event 1 state	0: OFF 1: ON
RX(n+11)6		Event 2 state	
RX(n+11)7		Burnout state	
RX(n+11)8		Heater break alarm (HBA) state	
RX(n+11)9		PID/AT transfer	
RX(n+11)A	CH49	Event 1 state	0: OFF 1: ON
RX(n+11)B		Event 2 state	
RX(n+11)C		Burnout state	
RX(n+11)D		Heater break alarm (HBA) state	
RX(n+11)E		PID/AT transfer	
RX(n+11)F	Unused	—	—
RX(n+12)0	CH50	Event 1 state	0: OFF 1: ON
RX(n+12)1		Event 2 state	
RX(n+12)2		Burnout state	
RX(n+12)3		Heater break alarm (HBA) state	
RX(n+12)4		PID/AT transfer	

Continued on the next page.

Continued from the previous page.

Address	Communication item		Data range	Factory set value
RX(n+12)5	CH51	Event 1 state	0: OFF 1: ON	—
RX(n+12)6		Event 2 state		—
RX(n+12)7		Burnout state		—
RX(n+12)8		Heater break alarm (HBA) state		—
RX(n+12)9		PID/AT transfer		0: PID control 1: Autotuning (AT)
RX(n+12)A	CH52	Event 1 state	0: OFF 1: ON	—
RX(n+12)B		Event 2 state		—
RX(n+12)C		Burnout state		—
RX(n+12)D		Heater break alarm (HBA) state		—
RX(n+12)E		PID/AT transfer		0: PID control 1: Autotuning (AT)
RX(n+12)F	Unused		—	—
RX(n+13)0	CH53	Event 1 state	0: OFF 1: ON	—
RX(n+13)1		Event 2 state		—
RX(n+13)2		Burnout state		—
RX(n+13)3		Heater break alarm (HBA) state		—
RX(n+13)4		PID/AT transfer		0: PID control 1: Autotuning (AT)
RX(n+13)5	CH54	Event 1 state	0: OFF 1: ON	—
RX(n+13)6		Event 2 state		—
RX(n+13)7		Burnout state		—
RX(n+13)8		Heater break alarm (HBA) state		—
RX(n+13)9		PID/AT transfer		0: PID control 1: Autotuning (AT)
RX(n+13)A	CH55	Event 1 state	0: OFF 1: ON	—
RX(n+13)B		Event 2 state		—
RX(n+13)C		Burnout state		—
RX(n+13)D		Heater break alarm (HBA) state		—
RX(n+13)E		PID/AT transfer		0: PID control 1: Autotuning (AT)
RX(n+13)F	Unused		—	—
RX(n+14)0	CH56	Event 1 state	0: OFF 1: ON	—
RX(n+14)1		Event 2 state		—
RX(n+14)2		Burnout state		—
RX(n+14)3		Heater break alarm (HBA) state		—
RX(n+14)4		PID/AT transfer		0: PID control 1: Autotuning (AT)
RX(n+14)5	CH57	Event 1 state	0: OFF 1: ON	—
RX(n+14)6		Event 2 state		—
RX(n+14)7		Burnout state		—
RX(n+14)8		Heater break alarm (HBA) state		—
RX(n+14)9		PID/AT transfer		0: PID control 1: Autotuning (AT)
RX(n+14)A	CH58	Event 1 state	0: OFF 1: ON	—
RX(n+14)B		Event 2 state		—
RX(n+14)C		Burnout state		—
RX(n+14)D		Heater break alarm (HBA) state		—
RX(n+14)E		PID/AT transfer		0: PID control 1: Autotuning (AT)

Continued on the next page.

7. COMMUNICATION DATA LIST

Continued from the previous page.

Address	Communication item	Data range	Factory set value
RX(n+14)F	Unused	—	—
RX(n+15)0	CH59	Event 1 state	0: OFF 1: ON
RX(n+15)1		Event 2 state	
RX(n+15)2		Burnout state	
RX(n+15)3		Heater break alarm (HBA) state	
RX(n+15)4		PID/AT transfer	
RX(n+15)5	CH60	Event 1 state	0: OFF 1: ON
RX(n+15)6		Event 2 state	
RX(n+15)7		Burnout state	
RX(n+15)8		Heater break alarm (HBA) state	
RX(n+15)9		PID/AT transfer	
RX(n+15)A	CH61	Event 1 state	0: OFF 1: ON
RX(n+15)B		Event 2 state	
RX(n+15)C		Burnout state	
RX(n+15)D		Heater break alarm (HBA) state	
RX(n+15)E		PID/AT transfer	
RX(n+15)F	Unused	—	—
RX(n+16)0	CH62	Event 1 state	0: OFF 1: ON
RX(n+16)1		Event 2 state	
RX(n+16)2		Burnout state	
RX(n+16)3		Heater break alarm (HBA) state	
RX(n+16)4		PID/AT transfer	
RX(n+16)5	CH63	Event 1 state	0: OFF 1: ON
RX(n+16)6		Event 2 state	
RX(n+16)7		Burnout state	
RX(n+16)8		Heater break alarm (HBA) state	
RX(n+16)9		PID/AT transfer	
RX(n+16)A	CH64	Event 1 state	0: OFF 1: ON
RX(n+16)B		Event 2 state	
RX(n+16)C		Burnout state	
RX(n+16)D		Heater break alarm (HBA) state	
RX(n+16)E		PID/AT transfer	
RX(n+16)F ⋮ RX(n+1A)F	Unused	—	—
RX(n+1B)0 ⋮ RX(n+1B)7	Reserved	—	—
RX(n+1B)8	Initialize data processing request flag	0: OFF	—
RX(n+1B)9	Initialize data setting completion flag	1: ON	—

Continued on the next page.

Continued from the previous page.

Address	Communication item	Data range	Factory set value
RX(n+1B)A	Error status flag	0: OFF 1: ON Error status flag ON condition • Communication error.	—
RX(n+1B)B	Remote ready	0: Not ready state 1: Ready state	—
RX(n+1B)C ⋮ RX(n+1B)F	Reserved	—	—

■ Remote output

Data direction: Master station (PLC) → COM-JC (Remote device station)

Data capacity: 448-bit

Address	Communication item		Data range	Factory set value
RYn0	Bit 0	Extension number for display	Display extension number are specified by the ON/OFF states of RYn0 to RYn5 and RY(n+1)0 to RY(n+1)2. Data 0: OFF 1: ON [Decimal number: 0 to 511]	0
RYn1	Bit 1			
RYn2	Bit 2			
RYn3	Bit 3			
RYn4	Bit 4			
RYn5	Bit 5			
RYn6	Bit 0	Extension number for setting	Setting extension number are specified by the ON/OFF states of RYn6 to RYnB and RY(n+1)8 to RY(n+1)A. Data 0: OFF 1: ON [Decimal number: 0 to 511]	0
RYn7	Bit 1			
RYn8	Bit 2			
RYn9	Bit 3			
RYnA	Bit 4			
RYnB	Bit 5			
RYnC	Extended display flag		0: OFF	0
RYnD	Extended setting flag (Setting update flag)		1: ON	0
RYnE	Unused		—	—
RYnF	RUN/STOP transfer		Logic of RUN/STOP transfer is different by model code. For COM-JC*02-1 0: RUN (Control start) 1: STOP (Control stop) For COM-JC*02-2 0: STOP (Control stop) 1: RUN (Control start)	0
RY(n+1)0	Bit 6	Extension number for display Bit 9 to Bit 13: Unused	Display extension number are specified by the ON/OFF states of RYn0 to RYn5 and RY(n+1)0 to RY(n+1)2. Data 0: OFF 1: ON [Decimal number: 0 to 511]	0
RY(n+1)1	Bit 7			
RY(n+1)2	Bit 8			
RY(n+1)3	Bit 9			
RY(n+1)4	Bit 10			
RY(n+1)5	Bit 11			
RY(n+1)6	Bit 12			
RY(n+1)7	Bit 13			
RY(n+1)8	Bit 6	Extension number for setting Bit 9 to Bit 13: Unused	Setting extension number are specified by the ON/OFF states of RYn6 to RYnB and RY(n+1)8 to RY(n+1)A. Data 0: OFF 1: ON [Decimal number: 0 to 511]	0
RY(n+1)9	Bit 7			
RY(n+1)A	Bit 8			
RY(n+1)B	Bit 9			
RY(n+1)C	Bit 10			
RY(n+1)D	Bit 11			
RY(n+1)E	Bit 12			
RY(n+1)F	Bit 13			

Continued on the next page.

Continued from the previous page.

Address	Communication item		Data range	Factory set value
RY(n+2)0	Bit 0	Area number for display Bit 4 to Bit 7: Unused	Display area number are specified by the ON/OFF states of RY(n+2)0 to RY(n+2)3. Data 0: OFF 1: ON [Decimal number: 0 to 16] (0, 9 to 16: Control area)	0
RY(n+2)1	Bit 1			
RY(n+2)2	Bit 2			
RY(n+2)3	Bit 3			
RY(n+2)4	Bit 4			
RY(n+2)5	Bit 5			
RY(n+2)6	Bit 6			
RY(n+2)7	Bit 7			
RY(n+2)8	Bit 0	Area number for setting Bit 4 to Bit 7: Unused	Setting area number are specified by the ON/OFF states of RY(n+2)8 to RY(n+2)B. Data 0: OFF 1: ON [Decimal number: 0 to 16] (0, 9 to 16: Control area)	0
RY(n+2)9	Bit 1			
RY(n+2)A	Bit 2			
RY(n+2)B	Bit 3			
RY(n+2)C	Bit 4			
RY(n+2)D	Bit 5			
RY(n+2)E	Bit 6			
RY(n+2)F	Bit 7			
RY(n+3)0 ⋮ RY(n+1A)F	Unused		—	—
RY(n+1B)0 ⋮ RY(n+1B)7	Reserved		—	—
RY(n+1B)8	Initialize data processing completion flag		0: OFF 1: ON	0
RY(n+1B)9	Initialize data setting request flag			0
RY(n+1B)A	Error reset request flag			0
RY(n+1B)B ⋮ RY(n+1B)F	Reserved		—	—

7.2 Remote Register

Remote registers (RW_r, RW_w) are numeric data.

“n” in the table is the address assigned to the master station by the station number setting.

■ When the number of occupied station/extended cyclic settings are the same

It can be calculated by the following equation. However, the computing equation is when a network is configured only by using our COM-JCs and the number of all exclusive stations/extended cyclic are at the same setting.

Number of occupied station/ extended cyclic setting	Equation
1 station occupied 1 time	$n = (\text{Station number}^* - 1) \times 4$
4 stations occupied 1 time	$n = (\text{Station number}^* - 1) \times 4$
4 stations occupied 2 times	$n = (\text{Station number}^* - 1) \times 8$
4 stations occupied 4 times	$n = (\text{Station number}^* - 1) \times 16$

* Station number when there is one occupied station: 1 to 64 (each number can be set)
 Station number when there are four occupied stations: 1 to 61
 (four stations are occupied for each station number, and thus only numbers that are increments of four can be set: 1, 5, 9 ...61)

As the calculation result is expressed in decimal number it is converted to hexadecimal number before substituted for “n” in the table.

Example: When the COM-JC is set to 4 stations occupied 1 time and its station number is “5.”

$$n = (5 - 1) \times 4 = 16 \text{ (Decimal number)} \rightarrow 10 \text{ (Hexadecimal number)}$$

For station number 5: Remote registers RW_rn to RW_rn+F → RW_r10 to RW_r1F
 RW_wn to RW_wn+F → RW_w10 to RW_w1F

■ When the number of occupied station/extended cyclic settings are different

If the network consists of COM-JC modules with differing “number of occupied station/extended cyclic” settings, use for “n” the total of the number of assigned registers with station number lower than the module’s own station in order from the lowest station number.

Number of occupied station/ extended cyclic setting	Number of assigned registers
1 station occupied 1 time	4H (Hexadecimal number)
4 stations occupied 1 time	10H (Hexadecimal number)
4 stations occupied 2 times	20H (Hexadecimal number)
4 stations occupied 4 times	40H (Hexadecimal number)

Example: Calculation of “n” when the network consists of three COM-JC modules and the station numbers and “number of occupied station/extended cyclic” settings are as shown below.

1st module [Station number 1]: 4 stations occupied 2 times

n = 0 (No station numbers less than the module’s own station, thus 0)

Remote registers RW_rn to RW_rn+1F → RW_r0 to RW_r1F
 RW_wn to RW_wn+1F → RW_w0 to RW_w1F

2nd module [Station number 5]: 1 station occupied 1 time

n = 20 (The number of assigned registers of station 1)

Remote registers RW_rn to RW_rn+3 → RW_r20 to RW_r23
 RW_wn to RW_wn+3 → RW_w20 to RW_w23

3rd module [Station number 6]: 4 stations occupied 2 times

n = 20 + 4 = 24 (Total number of assigned registers of station 1 and station 5)

Remote registers RW_rn to RW_rn+F → RW_r24 to RW_r33
 RW_wn to RW_wn+F → RW_w24 to RW_w33

7.2.1 1 station occupied 1 time (1 channel assignment)

■ Remote register (RW_r)

Data direction: COM-JC (Remote device station) → Master station (PLC)

Data capacity: 4-word

Address	Communication item		Data range	Factory set value
RW _{rn}	CH1	Measured value (PV)	Input scale low to Input scale high	—
RW _{rn+1}		Manipulated output value (MV)	−5.0 to +105.0 %	—
RW _{rn+2}		Unused	—	—
RW _{rn+3}		For extended area display	Data corresponding to the extension number specified by setting the display extension number from RY _{n0} to RY _{n5} .	—

■ Remote register (RW_w)

Data direction: Master station (PLC) → COM-JC (Remote device station)

Data capacity: 4-word

Address	Communication item		Data range	Factory set value
RW _{wn}	CH1	Set value (SV)	Setting limiter low to Setting limiter high	0
RW _{wn+1}		Event 1 set value	Deviation action, Deviation action between channels: −Input span to +Input span Process action, SV action: Input scale low to Input scale high Manipulated output value (MV): −5.0 to +105.0 %	50
RW _{wn+2}		Event 2 set value		50
RW _{wn+3}		For extended area setting	Data corresponding to the extension number specified by setting the setting extension number from RY _{n6} to RY _{nB} .	—



When the Set value (SV), Event 1 set value, or Event 2 set value assigned to the Remote register (RW_w) as a fixed value is changed, operation of the extension setting flag (setting update flag) is also necessary. For details, refer to ■ **Extension number for setting selection processing (P. 24)**.

7.2.2 1 station occupied 1 time (2 channels assignment)

■ Remote register (RWr)

Data direction: COM-JC (Remote device station) → Master station (PLC)

Data capacity: 4-word

Address	Communication item		Data range	Factory set value
RW _{rn}	CH1	Measured value (PV)	Input scale low to Input scale high	—
RW _{rn+1}	CH2	Measured value (PV)		—
RW _{rn+2}	CH1	For extended area display	Data corresponding to the extension number specified by setting the display extension number from RY _{n0} to RY _{n5} .	—
RW _{rn+3}	CH2	For extended area display		—

■ Remote register (RWw)

Data direction: Master station (PLC) → COM-JC (Remote device station)

Data capacity: 4-word

Address	Communication item		Data range	Factory set value
RW _{wn}	CH1	Set value (SV)	Setting limiter low to Setting limiter high	0
RW _{wn+1}	CH2	Set value (SV)		0
RW _{wn+2}	CH1	For extended area setting	Data corresponding to the extension number specified by setting the setting extension number from RY _{n6} to RY _{nB} .	—
RW _{wn+3}	CH2	For extended area setting		—



When the Set value (SV) assigned to the Remote register (RWw) as a fixed value is changed, operation of the extension setting flag (setting update flag) is also necessary. For details, refer to ■ **Extension number for setting selection processing (P. 24)**.

7.2.3 4 stations occupied 1 time (8 channels assignment)

■ Remote register (RWr)

Data direction: COM-JC (Remote device station) → Master station (PLC)

Data capacity: 16-word

Address	Communication item		Data range	Factory set value
RWr _n	CH1	Measured value (PV)	Input scale low to Input scale high	—
RWr _{n+1}	CH2	Measured value (PV)		—
RWr _{n+2}	CH3	Measured value (PV)		—
RWr _{n+3}	CH4	Measured value (PV)		—
RWr _{n+4}	CH5	Measured value (PV)		—
RWr _{n+5}	CH6	Measured value (PV)		—
RWr _{n+6}	CH7	Measured value (PV)		—
RWr _{n+7}	CH8	Measured value (PV)		—
RWr _{n+8}	CH1	For extended area display	Data corresponding to the extension number specified by setting the display extension number from RY _{n0} to RY _{n5} and from RY _{(n+1)0} to RY _{(n+1)2} .	—
RWr _{n+9}	CH2	For extended area display		—
RWr _{n+A}	CH3	For extended area display		—
RWr _{n+B}	CH4	For extended area display		—
RWr _{n+C}	CH5	For extended area display		—
RWr _{n+D}	CH6	For extended area display		—
RWr _{n+E}	CH7	For extended area display		—
RWr _{n+F}	CH8	For extended area display		—

■ Remote register (RWw)

Data direction: Master station (PLC) → COM-JC (Remote device station)

Data capacity: 16-word

Address	Communication item		Data range	Factory set value
RWw _n	CH1	Set value (SV)	Setting limiter low to Setting limiter high	0
RWw _{n+1}	CH2	Set value (SV)		0
RWw _{n+2}	CH3	Set value (SV)		0
RWw _{n+3}	CH4	Set value (SV)		0
RWw _{n+4}	CH5	Set value (SV)		0
RWw _{n+5}	CH6	Set value (SV)		0
RWw _{n+6}	CH7	Set value (SV)		0
RWw _{n+7}	CH8	Set value (SV)		0
RWw _{n+8}	CH1	For extended area setting	Data corresponding to the extension number specified by setting the setting extension number from RY _{n6} to RY _{nB} and from RY _{(n+1)8} to RY _{(n+1)A} .	—
RWw _{n+9}	CH2	For extended area setting		—
RWw _{n+A}	CH3	For extended area setting		—
RWw _{n+B}	CH4	For extended area setting		—
RWw _{n+C}	CH5	For extended area setting		—
RWw _{n+D}	CH6	For extended area setting		—
RWw _{n+E}	CH7	For extended area setting		—
RWw _{n+F}	CH8	For extended area setting		—



When the Set value (SV) assigned to the Remote register (RWw) as a fixed value is changed, operation of the extension setting flag (setting update flag) is also necessary. For details, refer to ■ **Extension number for setting selection processing (P. 24)**.

7.2.4 4 stations occupied 1 time (16 channels assignment)

■ Remote register (RW_r)

Data direction: COM-JC (Remote device station) → Master station (PLC)

Data capacity: 16-word

Address	Communication item		Data range	Factory set value
RW _r n	CH1	For extended area display	Data corresponding to the extension number specified by setting the display extension number from RY _n 0 to RY _n 5 and from RY _(n+1) 0 to RY _(n+1) 2.	—
RW _r n+1	CH2	For extended area display		—
RW _r n+2	CH3	For extended area display		—
RW _r n+3	CH4	For extended area display		—
RW _r n+4	CH5	For extended area display		—
RW _r n+5	CH6	For extended area display		—
RW _r n+6	CH7	For extended area display		—
RW _r n+7	CH8	For extended area display		—
RW _r n+8	CH9	For extended area display		—
RW _r n+9	CH10	For extended area display		—
RW _r n+A	CH11	For extended area display		—
RW _r n+B	CH12	For extended area display		—
RW _r n+C	CH13	For extended area display		—
RW _r n+D	CH14	For extended area display		—
RW _r n+E	CH15	For extended area display		—
RW _r n+F	CH16	For extended area display		—

■ Remote register (RW_w)

Data direction: Master station (PLC) → COM-JC (Remote device station)

Data capacity: 16-word

Address	Communication item		Data range	Factory set value
RW _w n	CH1	For extended area setting	Data corresponding to the extension number specified by setting the setting extension number from RY _n 6 to RY _n B and from RY _(n+1) 8 to RY _(n+1) A.	—
RW _w n+1	CH2	For extended area setting		—
RW _w n+2	CH3	For extended area setting		—
RW _w n+3	CH4	For extended area setting		—
RW _w n+4	CH5	For extended area setting		—
RW _w n+5	CH6	For extended area setting		—
RW _w n+6	CH7	For extended area setting		—
RW _w n+7	CH8	For extended area setting		—
RW _w n+8	CH9	For extended area setting		—
RW _w n+9	CH10	For extended area setting		—
RW _w n+A	CH11	For extended area setting		—
RW _w n+B	CH12	For extended area setting		—
RW _w n+C	CH13	For extended area setting		—
RW _w n+D	CH14	For extended area setting		—
RW _w n+E	CH15	For extended area setting		—
RW _w n+F	CH16	For extended area setting		—

7.2.5 4 stations occupied 2 times (16 channels assignment)

■ Remote register (RWr)

Data direction: COM-JC (Remote device station) → Master station (PLC)

Data capacity: 32-word

Address	Communication item		Data range	Factory set value
RWr _n	CH1	Measured value (PV)	Input scale low to Input scale high	—
RWr _{n+1}	CH2	Measured value (PV)		—
RWr _{n+2}	CH3	Measured value (PV)		—
RWr _{n+3}	CH4	Measured value (PV)		—
RWr _{n+4}	CH5	Measured value (PV)		—
RWr _{n+5}	CH6	Measured value (PV)		—
RWr _{n+6}	CH7	Measured value (PV)		—
RWr _{n+7}	CH8	Measured value (PV)		—
RWr _{n+8}	CH9	Measured value (PV)		—
RWr _{n+9}	CH10	Measured value (PV)		—
RWr _{n+A}	CH11	Measured value (PV)		—
RWr _{n+B}	CH12	Measured value (PV)		—
RWr _{n+C}	CH13	Measured value (PV)		—
RWr _{n+D}	CH14	Measured value (PV)		—
RWr _{n+E}	CH15	Measured value (PV)		—
RWr _{n+F}	CH16	Measured value (PV)		—
RWr _{n+10}	CH1	For extended area display	Data corresponding to the extension number specified by setting the display extension number from RY _{n0} to RY _{n5} and from RY _{(n+1)0} to RY _{(n+1)2} .	—
RWr _{n+11}	CH2	For extended area display		—
RWr _{n+12}	CH3	For extended area display		—
RWr _{n+13}	CH4	For extended area display		—
RWr _{n+14}	CH5	For extended area display		—
RWr _{n+15}	CH6	For extended area display		—
RWr _{n+16}	CH7	For extended area display		—
RWr _{n+17}	CH8	For extended area display		—
RWr _{n+18}	CH9	For extended area display		—
RWr _{n+19}	CH10	For extended area display		—
RWr _{n+1A}	CH11	For extended area display		—
RWr _{n+1B}	CH12	For extended area display		—
RWr _{n+1C}	CH13	For extended area display		—
RWr _{n+1D}	CH14	For extended area display		—
RWr _{n+1E}	CH15	For extended area display		—
RWr _{n+1F}	CH16	For extended area display		—

■ Remote register (RWw)

Data direction: Master station (PLC) → COM-JC (Remote device station)

Data capacity: 32-word

Address	Communication item		Data range	Factory set value
RW _{wn}	CH1	Set value (SV)	Setting limiter low to Setting limiter high	0
RW _{wn+1}	CH2	Set value (SV)		0
RW _{wn+2}	CH3	Set value (SV)		0
RW _{wn+3}	CH4	Set value (SV)		0
RW _{wn+4}	CH5	Set value (SV)		0
RW _{wn+5}	CH6	Set value (SV)		0
RW _{wn+6}	CH7	Set value (SV)		0
RW _{wn+7}	CH8	Set value (SV)		0
RW _{wn+8}	CH9	Set value (SV)		0
RW _{wn+9}	CH10	Set value (SV)		0
RW _{wn+A}	CH11	Set value (SV)		0
RW _{wn+B}	CH12	Set value (SV)		0
RW _{wn+C}	CH13	Set value (SV)		0
RW _{wn+D}	CH14	Set value (SV)		0
RW _{wn+E}	CH15	Set value (SV)		0
RW _{wn+F}	CH16	Set value (SV)		0
RW _{wn+10}	CH1	For extended area setting	Data corresponding to the extension number specified by setting the setting extension number from RY _{n6} to RY _{nB} and from RY _{(n+1)8} to RY _{(n+1)A} .	—
RW _{wn+11}	CH2	For extended area setting		—
RW _{wn+12}	CH3	For extended area setting		—
RW _{wn+13}	CH4	For extended area setting		—
RW _{wn+14}	CH5	For extended area setting		—
RW _{wn+15}	CH6	For extended area setting		—
RW _{wn+16}	CH7	For extended area setting		—
RW _{wn+17}	CH8	For extended area setting		—
RW _{wn+18}	CH9	For extended area setting		—
RW _{wn+19}	CH10	For extended area setting		—
RW _{wn+1A}	CH11	For extended area setting		—
RW _{wn+1B}	CH12	For extended area setting		—
RW _{wn+1C}	CH13	For extended area setting		—
RW _{wn+1D}	CH14	For extended area setting		—
RW _{wn+1E}	CH15	For extended area setting		—
RW _{wn+1F}	CH16	For extended area setting		—



When the Set value (SV) assigned to the Remote register (RWw) as a fixed value is changed, operation of the extension setting flag (setting update flag) is also necessary. For details, refer to ■ **Extension number for setting selection processing (P. 24)**.

7.2.6 4 stations occupied 2 times (32 channels assignment)

■ Remote register (RWr)

Data direction: COM-JC (Remote device station) → Master station (PLC)

Data capacity: 32-word

Address	Communication item		Data range	Factory set value
RWr _n	CH1	For extended area display	Data corresponding to the extension number specified by setting the display extension number from RY _n 0 to RY _n 5 and from RY _(n+1) 0 to RY _(n+1) 2.	—
RWr _{n+1}	CH2	For extended area display		—
RWr _{n+2}	CH3	For extended area display		—
RWr _{n+3}	CH4	For extended area display		—
RWr _{n+4}	CH5	For extended area display		—
RWr _{n+5}	CH6	For extended area display		—
RWr _{n+6}	CH7	For extended area display		—
RWr _{n+7}	CH8	For extended area display		—
RWr _{n+8}	CH9	For extended area display		—
RWr _{n+9}	CH10	For extended area display		—
RWr _{n+A}	CH11	For extended area display		—
RWr _{n+B}	CH12	For extended area display		—
RWr _{n+C}	CH13	For extended area display		—
RWr _{n+D}	CH14	For extended area display		—
RWr _{n+E}	CH15	For extended area display		—
RWr _{n+F}	CH16	For extended area display		—
RWr _{n+10}	CH17	For extended area display		—
RWr _{n+11}	CH18	For extended area display		—
RWr _{n+12}	CH19	For extended area display		—
RWr _{n+13}	CH20	For extended area display		—
RWr _{n+14}	CH21	For extended area display		—
RWr _{n+15}	CH22	For extended area display		—
RWr _{n+16}	CH23	For extended area display		—
RWr _{n+17}	CH24	For extended area display		—
RWr _{n+18}	CH25	For extended area display		—
RWr _{n+19}	CH26	For extended area display		—
RWr _{n+1A}	CH27	For extended area display		—
RWr _{n+1B}	CH28	For extended area display		—
RWr _{n+1C}	CH29	For extended area display		—
RWr _{n+1D}	CH30	For extended area display		—
RWr _{n+1E}	CH31	For extended area display		—
RWr _{n+1F}	CH32	For extended area display		—

■ Remote register (RWw)

Data direction: Master station (PLC) → COM-JC (Remote device station)

Data capacity: 32-word

Address	Communication item		Data range	Factory set value
RW _{wn}	CH1	For extended area setting	Data corresponding to the extension number specified by setting the setting extension number from RY _{n6} to RY _{nB} and from RY _{(n+1)8} to RY _{(n+1)A} .	—
RW _{wn+1}	CH2	For extended area setting		—
RW _{wn+2}	CH3	For extended area setting		—
RW _{wn+3}	CH4	For extended area setting		—
RW _{wn+4}	CH5	For extended area setting		—
RW _{wn+5}	CH6	For extended area setting		—
RW _{wn+6}	CH7	For extended area setting		—
RW _{wn+7}	CH8	For extended area setting		—
RW _{wn+8}	CH9	For extended area setting		—
RW _{wn+9}	CH10	For extended area setting		—
RW _{wn+A}	CH11	For extended area setting		—
RW _{wn+B}	CH12	For extended area setting		—
RW _{wn+C}	CH13	For extended area setting		—
RW _{wn+D}	CH14	For extended area setting		—
RW _{wn+E}	CH15	For extended area setting		—
RW _{wn+F}	CH16	For extended area setting		—
RW _{wn+10}	CH17	For extended area setting		—
RW _{wn+11}	CH18	For extended area setting		—
RW _{wn+12}	CH19	For extended area setting		—
RW _{wn+13}	CH20	For extended area setting		—
RW _{wn+14}	CH21	For extended area setting		—
RW _{wn+15}	CH22	For extended area setting		—
RW _{wn+16}	CH23	For extended area setting		—
RW _{wn+17}	CH24	For extended area setting		—
RW _{wn+18}	CH25	For extended area setting		—
RW _{wn+19}	CH26	For extended area setting		—
RW _{wn+1A}	CH27	For extended area setting		—
RW _{wn+1B}	CH28	For extended area setting		—
RW _{wn+1C}	CH29	For extended area setting		—
RW _{wn+1D}	CH30	For extended area setting		—
RW _{wn+1E}	CH31	For extended area setting		—
RW _{wn+1F}	CH32	For extended area setting		—

7.2.7 4 stations occupied 4 times (32 channels assignment)

■ Remote register (RWr)

Data direction: COM-JC (Remote device station) → Master station (PLC)

Data capacity: 64-word

Address	Communication item		Data range	Factory set value
RWr _n	CH1	Measured value (PV)	Input scale low to Input scale high	—
RWr _{n+1}	CH2	Measured value (PV)		—
RWr _{n+2}	CH3	Measured value (PV)		—
RWr _{n+3}	CH4	Measured value (PV)		—
RWr _{n+4}	CH5	Measured value (PV)		—
RWr _{n+5}	CH6	Measured value (PV)		—
RWr _{n+6}	CH7	Measured value (PV)		—
RWr _{n+7}	CH8	Measured value (PV)		—
RWr _{n+8}	CH9	Measured value (PV)		—
RWr _{n+9}	CH10	Measured value (PV)		—
RWr _{n+A}	CH11	Measured value (PV)		—
RWr _{n+B}	CH12	Measured value (PV)		—
RWr _{n+C}	CH13	Measured value (PV)		—
RWr _{n+D}	CH14	Measured value (PV)		—
RWr _{n+E}	CH15	Measured value (PV)		—
RWr _{n+F}	CH16	Measured value (PV)		—
RWr _{n+10}	CH17	Measured value (PV)		—
RWr _{n+11}	CH18	Measured value (PV)		—
RWr _{n+12}	CH19	Measured value (PV)		—
RWr _{n+13}	CH20	Measured value (PV)		—
RWr _{n+14}	CH21	Measured value (PV)		—
RWr _{n+15}	CH22	Measured value (PV)		—
RWr _{n+16}	CH23	Measured value (PV)		—
RWr _{n+17}	CH24	Measured value (PV)		—
RWr _{n+18}	CH25	Measured value (PV)		—
RWr _{n+19}	CH26	Measured value (PV)		—
RWr _{n+1A}	CH27	Measured value (PV)		—
RWr _{n+1B}	CH28	Measured value (PV)		—
RWr _{n+1C}	CH29	Measured value (PV)		—
RWr _{n+1D}	CH30	Measured value (PV)		—
RWr _{n+1E}	CH31	Measured value (PV)		—
RWr _{n+1F}	CH32	Measured value (PV)		—
RWr _{n+20}	CH1	For extended area display	Data corresponding to the extension number specified by setting the display extension number from RY _{n0} to RY _{n5} and from RY _{(n+1)0} to RY _{(n+1)2} .	—
RWr _{n+21}	CH2	For extended area display		—
RWr _{n+22}	CH3	For extended area display		—
RWr _{n+23}	CH4	For extended area display		—
RWr _{n+24}	CH5	For extended area display		—
RWr _{n+25}	CH6	For extended area display		—
RWr _{n+26}	CH7	For extended area display		—
RWr _{n+27}	CH8	For extended area display		—
RWr _{n+28}	CH9	For extended area display		—
RWr _{n+29}	CH10	For extended area display		—
RWr _{n+2A}	CH11	For extended area display		—

Continued on the next page.

Continued from the previous page.

Address	Communication item		Data range	Factory set value
RWr _n +2B	CH12	For extended area display	Data corresponding to the extension number specified by setting the display extension number from RY _n 0 to RY _n 5 and from RY _(n+1) 0 to RY _(n+1) 2.	—
RWr _n +2C	CH13	For extended area display		—
RWr _n +2D	CH14	For extended area display		—
RWr _n +2E	CH15	For extended area display		—
RWr _n +2F	CH16	For extended area display		—
RWr _n +30	CH17	For extended area display		—
RWr _n +31	CH18	For extended area display		—
RWr _n +32	CH19	For extended area display		—
RWr _n +33	CH20	For extended area display		—
RWr _n +34	CH21	For extended area display		—
RWr _n +35	CH22	For extended area display		—
RWr _n +36	CH23	For extended area display		—
RWr _n +37	CH24	For extended area display		—
RWr _n +38	CH25	For extended area display		—
RWr _n +39	CH26	For extended area display		—
RWr _n +3A	CH27	For extended area display		—
RWr _n +3B	CH28	For extended area display		—
RWr _n +3C	CH29	For extended area display		—
RWr _n +3D	CH30	For extended area display		—
RWr _n +3E	CH31	For extended area display		—
RWr _n +3F	CH32	For extended area display	—	

■ Remote register (RWw)

Data direction: Master station (PLC) → COM-JC (Remote device station)

Data capacity: 64-word

Address	Communication item		Data range	Factory set value
RW _{wn}	CH1	Set value (SV)	Setting limiter low to Setting limiter high	0
RW _{wn+1}	CH2	Set value (SV)		0
RW _{wn+2}	CH3	Set value (SV)		0
RW _{wn+3}	CH4	Set value (SV)		0
RW _{wn+4}	CH5	Set value (SV)		0
RW _{wn+5}	CH6	Set value (SV)		0
RW _{wn+6}	CH7	Set value (SV)		0
RW _{wn+7}	CH8	Set value (SV)		0
RW _{wn+8}	CH9	Set value (SV)		0
RW _{wn+9}	CH10	Set value (SV)		0
RW _{wn+A}	CH11	Set value (SV)		0
RW _{wn+B}	CH12	Set value (SV)		0
RW _{wn+C}	CH13	Set value (SV)		0
RW _{wn+D}	CH14	Set value (SV)		0
RW _{wn+E}	CH15	Set value (SV)		0
RW _{wn+F}	CH16	Set value (SV)		0
RW _{wn+10}	CH17	Set value (SV)		0
RW _{wn+11}	CH18	Set value (SV)		0
RW _{wn+12}	CH19	Set value (SV)		0
RW _{wn+13}	CH20	Set value (SV)		0
RW _{wn+14}	CH21	Set value (SV)		0
RW _{wn+15}	CH22	Set value (SV)		0
RW _{wn+16}	CH23	Set value (SV)		0
RW _{wn+17}	CH24	Set value (SV)		0
RW _{wn+18}	CH25	Set value (SV)		0
RW _{wn+19}	CH26	Set value (SV)		0
RW _{wn+1A}	CH27	Set value (SV)		0
RW _{wn+1B}	CH28	Set value (SV)		0
RW _{wn+1C}	CH29	Set value (SV)		0
RW _{wn+1D}	CH30	Set value (SV)		0
RW _{wn+1E}	CH31	Set value (SV)		0
RW _{wn+1F}	CH32	Set value (SV)		0
RW _{wn+20}	CH1	For extended area setting	Data corresponding to the extension number specified by setting the setting extension number from RY _{n6} to RY _{nB} and from RY _{(n+1)8} to RY _{(n+1)A} .	—
RW _{wn+21}	CH2	For extended area setting		—
RW _{wn+22}	CH3	For extended area setting		—
RW _{wn+23}	CH4	For extended area setting		—
RW _{wn+24}	CH5	For extended area setting		—
RW _{wn+25}	CH6	For extended area setting		—
RW _{wn+26}	CH7	For extended area setting		—
RW _{wn+27}	CH8	For extended area setting		—
RW _{wn+28}	CH9	For extended area setting		—
RW _{wn+29}	CH10	For extended area setting		—
RW _{wn+2A}	CH11	For extended area setting		—

Continued on the next page.

Continued from the previous page.

Address	Communication item		Data range	Factory set value
RWwn+2B	CH12	For extended area setting	Data corresponding to the extension number specified by setting the setting extension number from RYn6 to RYnB and from RY(n+1)8 to RY(n+1)A.	—
RWwn+2C	CH13	For extended area setting		—
RWwn+2D	CH14	For extended area setting		—
RWwn+2E	CH15	For extended area setting		—
RWwn+2F	CH16	For extended area setting		—
RWwn+30	CH17	For extended area setting		—
RWwn+31	CH18	For extended area setting		—
RWwn+32	CH19	For extended area setting		—
RWwn+33	CH20	For extended area setting		—
RWwn+34	CH21	For extended area setting		—
RWwn+35	CH22	For extended area setting		—
RWwn+36	CH23	For extended area setting		—
RWwn+37	CH24	For extended area setting		—
RWwn+38	CH25	For extended area setting		—
RWwn+39	CH26	For extended area setting		—
RWwn+3A	CH27	For extended area setting		—
RWwn+3B	CH28	For extended area setting		—
RWwn+3C	CH29	For extended area setting		—
RWwn+3D	CH30	For extended area setting		—
RWwn+3E	CH31	For extended area setting		—
RWwn+3F	CH32	For extended area setting	—	

7.2.8 4 stations occupied 4 times (64 channels assignment)

■ Remote register (RWr)

Data direction: COM-JC (Remote device station) → Master station (PLC)

Data capacity: 64-word

Address	Communication item		Data range	Factory set value
RWr _n	CH1	For extended area display	Data corresponding to the extension number specified by setting the display extension number from RY _n 0 to RY _n 5 and from RY _(n+1) 0 to RY _(n+1) 2.	—
RWr _{n+1}	CH2	For extended area display		—
RWr _{n+2}	CH3	For extended area display		—
RWr _{n+3}	CH4	For extended area display		—
RWr _{n+4}	CH5	For extended area display		—
RWr _{n+5}	CH6	For extended area display		—
RWr _{n+6}	CH7	For extended area display		—
RWr _{n+7}	CH8	For extended area display		—
RWr _{n+8}	CH9	For extended area display		—
RWr _{n+9}	CH10	For extended area display		—
RWr _{n+A}	CH11	For extended area display		—
RWr _{n+B}	CH12	For extended area display		—
RWr _{n+C}	CH13	For extended area display		—
RWr _{n+D}	CH14	For extended area display		—
RWr _{n+E}	CH15	For extended area display		—
RWr _{n+F}	CH16	For extended area display		—
RWr _{n+10}	CH17	For extended area display		—
RWr _{n+11}	CH18	For extended area display		—
RWr _{n+12}	CH19	For extended area display		—
RWr _{n+13}	CH20	For extended area display		—
RWr _{n+14}	CH21	For extended area display		—
RWr _{n+15}	CH22	For extended area display		—
RWr _{n+16}	CH23	For extended area display		—
RWr _{n+17}	CH24	For extended area display		—
RWr _{n+18}	CH25	For extended area display		—
RWr _{n+19}	CH26	For extended area display		—
RWr _{n+1A}	CH27	For extended area display		—
RWr _{n+1B}	CH28	For extended area display		—
RWr _{n+1C}	CH29	For extended area display		—
RWr _{n+1D}	CH30	For extended area display		—
RWr _{n+1E}	CH31	For extended area display		—
RWr _{n+1F}	CH32	For extended area display		—
RWr _{n+20}	CH33	For extended area display		—
RWr _{n+21}	CH34	For extended area display		—
RWr _{n+22}	CH35	For extended area display		—
RWr _{n+23}	CH36	For extended area display		—
RWr _{n+24}	CH37	For extended area display		—
RWr _{n+25}	CH38	For extended area display		—
RWr _{n+26}	CH39	For extended area display		—
RWr _{n+27}	CH40	For extended area display		—
RWr _{n+28}	CH41	For extended area display		—
RWr _{n+29}	CH42	For extended area display		—
RWr _{n+2A}	CH43	For extended area display		—

Continued on the next page.

Continued from the previous page.

Address	Communication item		Data range	Factory set value
RWr _n +2B	CH44	For extended area display	Data corresponding to the extension number specified by setting the display extension number from RY _n 0 to RY _n 5 and from RY _(n+1) 0 to RY _(n+1) 2.	—
RWr _n +2C	CH45	For extended area display		—
RWr _n +2D	CH46	For extended area display		—
RWr _n +2E	CH47	For extended area display		—
RWr _n +2F	CH48	For extended area display		—
RWr _n +30	CH49	For extended area display		—
RWr _n +31	CH50	For extended area display		—
RWr _n +32	CH51	For extended area display		—
RWr _n +33	CH52	For extended area display		—
RWr _n +34	CH53	For extended area display		—
RWr _n +35	CH54	For extended area display		—
RWr _n +36	CH55	For extended area display		—
RWr _n +37	CH56	For extended area display		—
RWr _n +38	CH57	For extended area display		—
RWr _n +39	CH58	For extended area display		—
RWr _n +3A	CH59	For extended area display		—
RWr _n +3B	CH60	For extended area display		—
RWr _n +3C	CH61	For extended area display		—
RWr _n +3D	CH62	For extended area display		—
RWr _n +3E	CH63	For extended area display		—
RWr _n +3F	CH64	For extended area display	—	

■ Remote register (RWw)

Data direction: Master station (PLC) → COM-JC (Remote device station)

Data capacity: 64-word

Address	Communication item		Data range	Factory set value
RW _{wn}	CH1	For extended area setting	Data corresponding to the extension number specified by setting the setting extension number from RY _n 6 to RY _n B and from RY _(n+1) 8 to RY _(n+1) A.	—
RW _{wn+1}	CH2	For extended area setting		—
RW _{wn+2}	CH3	For extended area setting		—
RW _{wn+3}	CH4	For extended area setting		—
RW _{wn+4}	CH5	For extended area setting		—
RW _{wn+5}	CH6	For extended area setting		—
RW _{wn+6}	CH7	For extended area setting		—
RW _{wn+7}	CH8	For extended area setting		—
RW _{wn+8}	CH9	For extended area setting		—
RW _{wn+9}	CH10	For extended area setting		—
RW _{wn+A}	CH11	For extended area setting		—
RW _{wn+B}	CH12	For extended area setting		—
RW _{wn+C}	CH13	For extended area setting		—
RW _{wn+D}	CH14	For extended area setting		—
RW _{wn+E}	CH15	For extended area setting		—
RW _{wn+F}	CH16	For extended area setting		—
RW _{wn+10}	CH17	For extended area setting		—
RW _{wn+11}	CH18	For extended area setting		—
RW _{wn+12}	CH19	For extended area setting		—
RW _{wn+13}	CH20	For extended area setting		—
RW _{wn+14}	CH21	For extended area setting		—
RW _{wn+15}	CH22	For extended area setting		—
RW _{wn+16}	CH23	For extended area setting		—
RW _{wn+17}	CH24	For extended area setting		—
RW _{wn+18}	CH25	For extended area setting		—
RW _{wn+19}	CH26	For extended area setting		—
RW _{wn+1A}	CH27	For extended area setting		—
RW _{wn+1B}	CH28	For extended area setting		—
RW _{wn+1C}	CH29	For extended area setting		—
RW _{wn+1D}	CH30	For extended area setting		—
RW _{wn+1E}	CH31	For extended area setting		—
RW _{wn+1F}	CH32	For extended area setting		—
RW _{wn+20}	CH33	For extended area setting		—
RW _{wn+21}	CH34	For extended area setting		—
RW _{wn+22}	CH35	For extended area setting		—
RW _{wn+23}	CH36	For extended area setting		—
RW _{wn+24}	CH37	For extended area setting		—
RW _{wn+25}	CH38	For extended area setting		—
RW _{wn+26}	CH39	For extended area setting		—
RW _{wn+27}	CH40	For extended area setting		—
RW _{wn+28}	CH41	For extended area setting		—
RW _{wn+29}	CH42	For extended area setting		—
RW _{wn+2A}	CH43	For extended area setting		—

Continued on the next page.



Continued from the previous page.

Address	Communication item		Data range	Factory set value
RWwn+2B	CH44	For extended area setting	Data corresponding to the extension number specified by setting the setting extension number from RYn6 to RYnB and from RY(n+1)8 to RY(n+1)A.	—
RWwn+2C	CH45	For extended area setting		—
RWwn+2D	CH46	For extended area setting		—
RWwn+2E	CH47	For extended area setting		—
RWwn+2F	CH48	For extended area setting		—
RWwn+30	CH49	For extended area setting		—
RWwn+31	CH50	For extended area setting		—
RWwn+32	CH51	For extended area setting		—
RWwn+33	CH52	For extended area setting		—
RWwn+34	CH53	For extended area setting		—
RWwn+35	CH54	For extended area setting		—
RWwn+36	CH55	For extended area setting		—
RWwn+37	CH56	For extended area setting		—
RWwn+38	CH57	For extended area setting		—
RWwn+39	CH58	For extended area setting		—
RWwn+3A	CH59	For extended area setting		—
RWwn+3B	CH60	For extended area setting		—
RWwn+3C	CH61	For extended area setting		—
RWwn+3D	CH62	For extended area setting		—
RWwn+3E	CH63	For extended area setting		—
RWwn+3F	CH64	For extended area setting	—	

7.3 Extension Number

Communication items which are handled in the extension areas of the remote registers (RWr and RWw) are specified by the extension number. If the necessary data is selected from a list of extension numbers and that extension number is set by remote output, the data can be handled in the remote registers (RWr and RWw).

In addition, communication item corresponding to memory area function specifies memory area number to use in remote register extension area for area number. Extension number and area number set in ON/OFF of remote output.

-  For remote output, refer to **7.1 Remote Input/Output (P. 29)**.
-  For remote register, refer to **7.2 Remote Register (P. 56)**.
-  For memory area function, refer to **SRZ Instruction Manual (IMR01T04-E□)**.

■ When read data

● Setting of extension number for display

Extension number for display sets it with remote output “RYn0 to RYn5 and RY(n+1)0 to RY(n+1)2.”

Bit image

RY(n+1)2	RY(n+1)1	RY(n+1)0	RYn5	RYn4	RYn3	RYn2	RYn1	RYn0
Bit 8	Bit 7	Bit 6	Bit 5	Bit 4	Bit 3	Bit 2	Bit 1	Bit 0

Bit data: 0: OFF 1: ON [Decimal number: 0 to 511]

-  For the 1station occupied 1 time setting, setting range of extension number becomes RYn0 to RYn5 [Decimal number: 0 to 63].

● Setting of area number for display

Area number for display sets it with remote output “RY(n+2)0 to RY(n+2)3.”

Bit image

RY(n+2)3	RY(n+2)2	RY(n+2)1	RY(n+2)0
Bit 3	Bit 2	Bit 1	Bit 0

Bit data: 0: OFF 1: ON [Decimal number: 0 to 16 (0, 9 to 16: Control area)]

-  For 1 station occupied 1 time setting, cannot do an assignment of area number. Become communication item of a control area.

■ **When write data**

● **Setting of extension number for setting**

Extension number for setting sets it with remote output “RYn6 to RynB and RY(n+1)8 to RY(n+1)A.”

Bit image

RY(n+1)A	RY(n+1)9	RY(n+1)8	RYnB	RYnA	RYn9	RYn8	RYn7	RYn6
Bit 8	Bit 7	Bit 6	Bit 5	Bit 4	Bit 3	Bit 2	Bit 1	Bit 0

Bit data: 0: OFF 1: ON [Decimal number: 0 to 511]



For the 1station occupied 1 time setting, setting range of extension number becomes RYn6 to RYnB [Decimal number: 0 to 63].

● **Setting of area number for setting**

Area number for setting sets it with remote output “RY(n+2)8 to RY(n+2)B.”

Bit image

RY(n+2)B	RY(n+2)A	RY(n+2)9	RY(n+2)8
Bit 3	Bit 2	Bit 1	Bit 0

Bit data: 0: OFF 1: ON [Decimal number: 0 to 16 (0, 9 to 16: Control area)]



For 1 station occupied 1 time setting, cannot do an assignment of area number. Become communication item of a control area.

[Example] When set extension number for setting to “3: Set value (SV),” and set area number for setting to “5.”

Number of occupied station/extended cyclic setting: 4 stations occupied 1 time

● **Setting of extension number for setting**

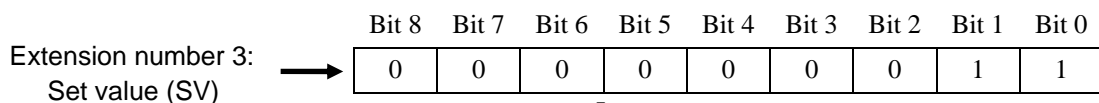

RY(n+1)A	RY(n+1)9	RY(n+1)8	RYnB	RYnA	RYn9	RYn8	RYn7	RYn6
OFF	OFF	OFF	OFF	OFF	OFF	OFF	ON	ON

Bit data: 0: OFF 1: ON

● **Setting of area number for setting**

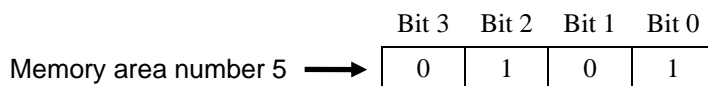

RY(n+2)B	RY(n+2)A	RY(n+2)9	RY(n+2)8
OFF	ON	OFF	ON

Bit data: 0: OFF 1: ON

■ Extension number list



Attribute:

RO: Read only data [Remote device station (COM-JC) → Master station (PLC)]

R/W: Read and Write data [Remote device station (COM-JC) ↔ Master station (PLC)]

Correspondence module and occupation CH:

Module types corresponding to each communication item and number of occupied channels per module

★: Data related multi-memory area function

♣: When Heat/Cool PID control or Position proportioning PID control is performed, the 2nd channel and 4th channel of Z-TIO module are invalid communication data.

[Read is possible (0 is shown), but the result of Write is disregarded.]

Extension number	Communication item	Attribute	Data range	Correspondence module and occupation CH	Factory set value
0	Measured value (PV)	RO	Input scale low to Input scale high Varies with the setting of the decimal point position selection.	Z-TIO: 4	—
1	Manipulated output value (MV) monitor [heat-side] ♣	RO	PID control or Heat/Cool PID control: –5.0 to +105.0 % Position proportioning PID control with feedback resistance (FBR) input: 0.0 to 100.0 %	Z-TIO: 4	—
2	Current transformer (CT) input value monitor	RO	0.0 to 30.0 A (CTL-6-P-N) 0.0 to 100.0 A (CTL-12-S56-10L-N)	Z-TIO: 4	—
3	Set value (SV) ★	R/W	Setting limiter low to Setting limiter high Varies with the setting of the decimal point position selection.	Z-TIO: 4	TC/RTD: 0 (0.0) V/I: 0.0
4	PID/AT transfer *	R/W	0: PID control 1: Autotuning (AT)	Z-TIO: 4	0
5	Proportional band [heat-side] ★♣	R/W	TC/RTD inputs: 0 (0.0) to Input span (Unit: °C [°F]) Varies with the setting of the decimal point position selection. Voltage (V)/Current (I) inputs: 0.0 to 1000.0 % of input span 0 (0.0): ON/OFF action ON/OFF action for both heat and cool actions in case of a Heat/Cool PID control type.	Z-TIO: 4	TC/RTD: 30 (30.0) V/I: 30.0
6	Integral time [heat-side] ★♣	R/W	PID control or Heat/Cool PID control: 0 to 3600 seconds or 0.0 to 1999.9 seconds (0, 0.0: PD action) Position proportioning PID control: 1 to 3600 seconds or 0.1 to 1999.9 seconds Varies with the setting of the Integral/Derivative time decimal point position selection.	Z-TIO: 4	240
7	Derivative time [heat-side] ★♣	R/W	0 to 3600 seconds or 0.0 to 1999.9 seconds (0, 0.0: PI action) Varies with the setting of the Integral/Derivative time decimal point position selection.	Z-TIO: 4	60
8	PV bias	R/W	–Input span to +Input span Varies with the setting of the decimal point position selection.	Z-TIO: 4	0 (0.0)

* For the operation, refer to the **6.2 CC-Link Flag Operation (P. 22)**.

Continued on the next page.

7. COMMUNICATION DATA LIST

Continued from the previous page.

Extension number	Communication item	Attribute	Data range	Correspondence module and occupation CH	Factory set value
9	Event 1 set value ★	R/W	Deviation action, Deviation action between channels: –Input span to +Input span Varies with the setting of the decimal point position selection. Process action, SV action: Input scale low to Input scale high Varies with the setting of the decimal point position selection. Manipulated output value (MV): –5.0 to +105 % If the Event type corresponds to “0: None,” set to RO (Only reading data is possible).	Z-TIO: 4	50 (50.0)
10	Event 2 set value ★	R/W	Deviation action, Deviation action between channels: –Input span to +Input span Varies with the setting of the decimal point position selection. Process action, SV action: Input scale low to Input scale high Varies with the setting of the decimal point position selection. Manipulated output value (MV): –5.0 to +105 % If the Event type corresponds to “0: None,” set to RO (Only reading data is possible).	Z-TIO: 4	50 (50.0)
11 ⋮ 15	Reserved	—	—	—	—
16	Unused	—	—	—	—
17	RUN/STOP transfer	R/W	Logic of RUN/STOP transfer is different by model code. COM-JC*02-1 0: RUN (Control start) 1: STOP (Control stop) COM-JC*02-2 0: STOP (Control stop) 1: RUN (Control start)	Z-TIO: 1 Z-DIO: 1	0
18	Proportional cycle time	R/W	0.1 to 100.0 seconds M: Relay contact output V: Voltage pulse output T: Triac output D: Open collector output This item becomes RO (Only reading data is possible) for the voltage/current output specification.	Z-TIO: 4	M: 20.0 V, T, D: 2.0
19	Auto/Manual transfer	R/W	0: Auto mode 1: Manual mode	Z-TIO: 4	0
20	Manual manipulated output value ♣	R/W	PID control: Output limiter low to Output limiter high Heat/Cool PID control: –Cool-side output limiter (high) to +Heat-side output limiter (high) Position proportioning PID control: When there is feedback resistance (FBR) input and it does not break: Output limiter low to Output limiter high When there is no feedback resistance (FBR) input or the feedback resistance (FBR) input is disconnected: 0: Close-side output OFF, Open-side output OFF 1: Close-side output ON, Open-side output OFF 2: Close-side output OFF, Open-side output ON	Z-TIO: 4	0.0
21	Setting limiter high	R/W	Setting limiter low to Input scale high Varies with the setting of the decimal point position selection.	Z-TIO: 4	Input scale high
22	Setting limiter low	R/W	Input scale low to Setting limiter high Varies with the setting of the decimal point position selection.	Z-TIO: 4	Input scale low

Continued on the next page.

Continued from the previous page.

Extension number	Communication item	Attribute	Data range	Correspondence module and occupation CH	Factory set value
23	PV digital filter	R/W	0.0 to 100.0 seconds (0.0: Unused)	Z-TIO: 4	0.0
24	Heater break alarm (HBA) set value	R/W	When CT is CTL-6-P-N: 0.0 to 30.0 A (0.0: Not used) When CT is CTL-12-S56-10L-N: 0.0 to 100.0 A (0.0: Not used) If there is no current transformer (CT) or CT is assigned to "0: None," set to RO (Only reading data is possible).	Z-TIO: 4	0.0
25	Decimal point position	R/W	0: No decimal place 1: One decimal place 2: Two decimal places 3: Three decimal places 4: Four decimal places TC input: • K, J, T, E Only 0 or 1 can be set. • R, S, B, N, PLII, W5Re/W26Re Only 0 can be set. RTD input: Only 0 or 1 can be set. V/I inputs: From 0 to 4 can be set.	Z-TIO: 4	Based on model code When not specifying: TC/RTD: 1 V/I: 1
26	Manipulated output value (MV) monitor [cool-side] ♣	RO	-5.0 to +105.0 %	Z-TIO: 4	—
27	Proportional band [cool-side] ★♣	R/W	TC/RTD inputs: 1 (0.1) to Input span (Unit: °C [°F]) Varies with the setting of the decimal point position selection. Voltage (V)/Current (I) inputs: 0.1 to 1000.0 % of input span If control is other than Heat/Cool PID control, set to RO (Only reading data is possible).	Z-TIO: 4	TC/RTD: 30 (30.0) V/I: 30.0
28	Unused	—	—	—	—
29	Overlap/Deadband ★♣	R/W	TC/RTD inputs: -Input span to +Input span (Unit: °C [°F]) Varies with the setting of the decimal point position selection. Voltage (V)/Current (I) inputs: -100.0 to +100.0 % of input span Minus (-) setting results in overlap. However, the overlapping range is within the proportional range. If control is other than Heat/Cool PID control, set to RO (Only reading data is possible).	Z-TIO: 4	0 (0.0)
30	Operation mode	R/W	0: Unused 1: Monitor 2: Monitor + Event function 3: Control	Z-TIO: 4	3
31	Set value (SV) monitor	RO	Setting limiter low to Setting limiter high Varies with the setting of the decimal point position selection.	Z-TIO: 4	—
32	Error code	RO	Bit data Bit 0: Adjustment data error Bit 1: Data back-up error Bit 2: A/D conversion error Bit 3, Bit 4: Unused Bit 5: Logic output data error Bit 6 to Bit 15: Unused Data 0: OFF 1: ON [Decimal number: 0 to 63]	Z-TIO: 1 Z-DIO: 1	—

Continued on the next page.

7. COMMUNICATION DATA LIST

Continued from the previous page.

Extension number	Communication item	Attribute	Data range	Correspondence module and occupation CH	Factory set value
33	Memory area transfer	R/W	1 to 8	Z-TIO: 4	1
34	Control response parameter ★♣	R/W	0: Slow 1: Medium 2: Fast When the P or PD action is selected, this setting becomes invalid.	Z-TIO: 4	PID control, Position proportioning PID control: 0 Heat/Cool PID control: 2
35	Unused	—	—	—	—
36	Input type	R/W	0: TC input K 1: TC input J 2: TC input R 3: TC input S 4: TC input B 5: TC input E 6: TC input N 7: TC input T 8: TC input W5Re/W26Re 9: TC input PLII 12: RTD input Pt100 13: RTD input JPt100 14: Current input 0 to 20 mA DC 15: Current input 4 to 20 mA DC 16: Voltage (high) input 0 to 10 V DC 17: Voltage (high) input 0 to 5 V DC 18: Voltage (high) input 1 to 5 V DC 19: Voltage (low) input 0 to 1 V DC 20: Voltage (low) input 0 to 100 mV DC 21: Voltage (low) input 0 to 10 mV DC 22: Feedback resistance input 100 to 150 Ω 23: Feedback resistance input 151 Ω to 6 kΩ If changed to Current/Voltage (high) input from TC/RTD/Voltage (low) input, select the hardware by the input selector switch (for measurement input) at the side of the instrument. For the selecting procedure, refer to the SRZ Instruction Manual (IMR01T04-E□) .	Z-TIO: 4	Based on model code. When not specifying: 0
37	Setting change rate limiter (up) ★	R/W	0 (0.0) to Input span/unit time * 0 (0.0): Unused Varies with the setting of the decimal point position selection. * Unit time: 60 seconds (factory set value)	Z-TIO: 4	0 (0.0)
38	Control action	R/W	0: Brilliant II PID control (direct action) 1: Brilliant II PID control (reverse action) 2: Brilliant II Heat/Cool PID control [water cooling] 3: Brilliant II Heat/Cool PID control [air cooling] 4: Brilliant II Heat/Cool PID control [Cooling gain linear type] 5: Brilliant II Position proportioning PID control Odd channel: From 0 to 5 can be set. Even channel: Only 0 or 1 can be set.	Z-TIO: 4	Based on model code. When not specifying: 1

Continued on the next page.

Continued from the previous page.

Extension number	Communication item	Attribute	Data range	Correspondence module and occupation CH	Factory set value
39	Event 1 type	R/W	0: None 1: Deviation high (Using SV monitor value) ¹ 2: Deviation low (Using SV monitor value) ¹ 3: Deviation high/low (Using SV monitor value) ¹ 4: Band (Using SV monitor value) ¹ 5: Process high ¹ 6: Process low ¹ 7: SV high 8: SV low 9: Unused 10: MV high [heat-side] ^{1,2} 11: MV low [heat-side] ^{1,2} 12: MV high [cool-side] ¹ 13: MV low [cool-side] ¹	Z-TIO: 4	Based on model code. When not specifying: 0
40	Event 2 type	R/W	14: Deviation high (Using local SV) ¹ 15: Deviation low (Using local SV) ¹ 16: Deviation high/low (Using local SV) ¹ 17: Band (Using local SV) ¹ 18: Deviation between channels high ¹ 19: Deviation between channels low ¹ 20: Deviation between channels high/low ¹ 21: Deviation between channels band ¹ ¹ Event hold action is available. ² If there is feedback resistance (FBR) input in Position proportioning PID control, set to the feedback resistance (FBR) input value.	Z-TIO: 4	Based on model code. When not specifying: 0
41	Event 1 differential gap	R/W	① Deviation, process, set value, or Deviation action between channels: 0 (0.0) to Input span (Unit: °C [°F]) Varies with the setting of the decimal point position selection.	Z-TIO: 4	①: 1 (1.0) ②: 1.0
42	Event 2 differential gap	R/W	② MV: 0.0 to 110.0 %	Z-TIO: 4	①: 1 (1.0) ②: 1.0
43	Event 1 hold action	R/W	0: OFF 1: Hold action ON (when power turned on; when transferred from STOP to RUN) 2: Re-hold action ON (when power turned on; when transferred from STOP to RUN; SV changed)	Z-TIO: 4	Based on model code. When not specifying: 0
44	Event 2 hold action	R/W	This function is valid when input value, deviation or manipulated value action has been selected. In case of a deviation action, this function is not available while in remote mode and while setting changing rate limiter is working.	Z-TIO: 4	Based on model code. When not specifying: 0
45	Unused	—	—	—	—
46	Output limiter high [heat-side] ♣	R/W	Output limiter low [heat-side] to 105.0 % Position proportioning PID control: Becomes valid only when there is feedback resistance (FBR) input and it does not break.	Z-TIO: 4	105.0
47	Output limiter low [heat-side] ♣	R/W	-5.0 % to Output limiter high [heat-side] Position proportioning PID control: Becomes valid only when there is feedback resistance (FBR) input and it does not break.	Z-TIO: 4	-5.0
48	Unused	—	—	—	—

Continued on the next page.

Continued from the previous page.

Extension number	Communication item	Attribute	Data range	Correspondence module and occupation CH	Factory set value
49	Unused	—	—	—	—
50	Control loop break alarm (LBA) time ★	R/W	0 to 7200 seconds (0: Unused) If Event 4 is other than “9: Control loop break alarm (LBA),” set to RO (Only reading data is possible).	Z-TIO: 4	480
51	LBA deadband ★	R/W	0 (0.0) to Input span Varies with the setting of the decimal point position selection. If Event 4 is other than “9: Control loop break alarm (LBA),” set to RO (Only reading data is possible).	Z-TIO: 4	0 (0.0)
52	Unused	—	—	—	—
53	Unused	—	—	—	—
54	Event 3 set value ★	R/W	Deviation action, Deviation action between channels, Temperature rise completion range: –Input span to +Input span Varies with the setting of the decimal point position selection. Process action, SV action: Input scale low to Input scale high Varies with the setting of the decimal point position selection.	Z-TIO: 4	50 (50.0)
55	Event 4 set value ★	R/W	MV action: –5.0 to +105.0 % If the Event type corresponds to “0: None,” set to RO (Only reading data is possible). When temperature rise completion is selected at Event3 action type. If Event 4 corresponds to “9: Control loop break alarm (LBA),” the Event 4 set value becomes RO (Only reading data is possible).	Z-TIO: 4	50 (50.0)
56	Event 3 type	R/W	0: None 1: Deviation high (SV monitor value used) ¹ 2: Deviation low (SV monitor value used) ¹ 3: Deviation high/low (SV monitor value used) ¹ 4: Band (SV monitor value used) ¹ 5: Process high ¹ 6: Process low ¹ 7: SV high 8: SV low 9: Event 3: Temperature rise completion Event 4: Control loop break alarm (LBA)	Z-TIO: 4	Based on model code. When not specifying: 0
57	Event 4 type	R/W	10: MV high [heat-side] ^{1, 2} 11: MV low [heat-side] ^{1, 2} 12: MV high [cool-side] ¹ 13: MV low [cool-side] ¹ 14: Deviation high (Local SV value used) ¹ 15: Deviation low (Local SV value used) ¹ 16: Deviation high/low (Local SV value used) ¹ 17: Band (Local SV value used) ¹ 18: Deviation between channels high ¹ 19: Deviation between channels low ¹ 20: Deviation between channels high/low ¹ 21: Deviation between channels band ¹ ¹ Event hold action is available. ² If there is feedback resistance (FBR) input in Position proportioning PID control, set to the feedback resistance (FBR) input value.	Z-TIO: 4	Based on model code. When not specifying: 0

Continued on the next page.

Continued from the previous page.

Extension number	Communication item	Attribute	Data range	Correspondence module and occupation CH	Factory set value
58	Event 3 differential gap	R/W	① Deviation, process, set value, or Deviation action between channels: 0 (0.0) to Input span (Unit: °C [°F]) Varies with the setting of the decimal point position selection. ② MV: 0.0 to 110.0 %	Z-TIO: 4	①: 1 (1.0) ②: 1.0
59	Event 4 differential gap	R/W		Z-TIO: 4	①: 1 (1.0) ②: 1.0
60	Event 3 hold action	R/W	0: OFF 1: Hold action ON (when power turned on; when transferred from STOP to RUN) 2: Re-hold action ON (when power turned on; when transferred from STOP to RUN; SV changed) This function is valid when input value, deviation or manipulated value action has been selected. In case of a deviation action, this function is not available while in remote mode and while setting changing rate limiter is working.	Z-TIO: 4	Based on model code. When not specifying: 0
61	Event 4 hold action	R/W		Z-TIO: 4	Based on model code. When not specifying: 0
62	Setting change rate limiter (down) ★	R/W	0 (0.0) to Input span/unit time * 0 (0.0): Unused Varies with the setting of the decimal point position selection. * Unit time: 60 seconds (factory set value)	Z-TIO: 4	0 (0.0)
63	Comprehensive event state	RO	Bit data Bit 0: Event 1 Bit 1: Event 2 Bit 2: Event 3 Bit 3: Event 4 Bit 4: Heater break alarm (HBA) state Bit 5: Temperature rise completion Bit 6: Burnout Bit 7 to Bit 15: Unused Data 0: OFF 1: ON [Decimal number: 0 to 127]	Z-TIO: 4	—
64	Remote setting (RS) input value monitor	RO	Setting limiter low to Setting limiter high Varies with the setting of the decimal point position selection.	Z-TIO: 4	—
65	Unused	—	—	—	—
66	Unused	—	—	—	—
67	Unused	—	—	—	—
68	Memory area soak time monitor	RO	0 to 11999 seconds or 0 to 5999 minutes Data range of Area soak time can be selected on the Soak time unit.	Z-TIO: 4	—
69	Digital input (DI) state monitor	RO	Bit data Bit 0: DI1 Bit 5: DI6 Bit 1: DI2 Bit 6: DI7 Bit 2: DI3 Bit 7: DI8 Bit 3: DI4 Bit 8 to Bit 15: Unused Bit 4: DI5 Data 0: Open 1: Closed [Decimal number: 0 to 255]	Z-DIO: 1	—

Continued on the next page.

7. COMMUNICATION DATA LIST

Continued from the previous page.

Extension number	Communication item	Attribute	Data range	Correspondence module and occupation CH	Factory set value
70	Operation mode state monitor	RO	Bit data Bit 0: Control STOP Bit 1: Control RUN Bit 2: Manual mode Bit 3: Remote mode Bit 4 to Bit 15: Unused Data 0: OFF 1: ON [Decimal number: 0 to 15]	Z-TIO: 4	—
71	Unused	—	—	—	—
72	Unused	—	—	—	—
73	Digital output (DO) state	RO	Bit data Bit 0: DO1 Bit 5: DO6 Bit 1: DO2 Bit 6: DO7 Bit 2: DO3 Bit 7: DO8 Bit 3: DO4 Bit 8 to Bit 15: Unused Bit 4: DO5 Data 0: Open 1: Closed [Decimal number: 0 to 255]	Z-DIO: 1	—
74	Output state monitor	RO	Bit data Bit 0: OUT1 Bit 1: OUT2 Bit 2: OUT3 Bit 3: OUT4 Bit 4 to Bit 15: Unused Data 0: OFF 1: ON [Decimal number: 0 to 15] Valid only for time-proportional control output.	Z-TIO: 1	—
75 ⋮ 89	Unused	—	—	—	—
90	Remote/Local transfer	R/W	0: Local mode 1: Remote mode When performing remote control by remote setting input and also performing cascade control and ratio setting via intercontroller communication, transfer to the remote mode.	Z-TIO: 4	0
91	Unused	—	—	—	—
92	Interlock release	R/W	0: Normal state 1: Interlock release execution	Z-TIO: 4	0
93	Communication switch for logic	R/W	Bit data Bit 0: Communication switch 1 Bit 1: Communication switch 2 Bit 2: Communication switch 3 Bit 3: Communication switch 4 Bit 4 to Bit 15: Unused Data 0: OFF 1: ON [Decimal number: 0 to 15]	Z-TIO: 1	0

Continued on the next page.

Continued from the previous page.

Extension number	Communication item	Attribute	Data range	Correspondence module and occupation CH	Factory set value
94	DO manual output	R/W	Bit data Bit 0: DO1 manual output Bit 1: DO2 manual output Bit 2: DO3 manual output Bit 3: DO4 manual output Bit 4: DO5 manual output Bit 5: DO6 manual output Bit 6: DO7 manual output Bit 7: DO8 manual output Bit 8 to Bit 15: Unused Data 0: OFF 1: ON [Decimal number: 0 to 255]	Z-DIO: 1	0
95 ⋮ 109	Unused	—	—	—	—
110	Link area number ★	R/W	0 to 8 (0: No link)	Z-TIO: 4	0
111	Area soak time ★	R/W	0 to 11999 seconds or 0 to 5999 minutes Data range of Area soak time can be selected on the Soak time unit.	Z-TIO: 4	0
112	Integral time [cool-side] ★♣	R/W	0 to 3600 seconds or 0.0 to 1999.9 seconds (0, 0.0: PD action) * Varies with the setting of the Integral/Derivative time decimal point position selection. If control is other than Heat/Cool PID control, set to RO (Only reading data is possible).	Z-TIO: 4	240
113	Derivative time [cool-side] ★♣	R/W	0 to 3600 seconds or 0.0 to 1999.9 seconds (0, 0.0: PI action) Varies with the setting of the Integral/Derivative time decimal point position selection. If control is other than Heat/Cool PID control, set to RO (Only reading data is possible).	Z-TIO: 4	60
114 ⋮ 127	Unused	—	—	—	—
128	Manual reset ★	R/W	-100.0 to +100.0 % If the integral function is valid, set to RO (Only reading data is possible). When integral action (heating or cooling side) is zero, manual reset value is added to the control output.	Z-TIO: 4	0.0
129	Area soak time stop function	R/W	0: No function 1: Event 1 2: Event 2 3: Event 3 4: Event 4	Z-TIO: 4	0
130	Minimum ON/OFF time of proportioning cycle	R/W	0 to 1000 ms This item becomes RO (Only reading data is possible) for the Voltage/Current output specification.	Z-TIO: 4	0
131	DO minimum ON/OFF time of proportional cycle	R/W	0 to 1000 ms	Z-DIO: 8	0
132	DO proportional cycle time	R/W	0.1 to 100.0 seconds M: Relay contact D: Open collector	Z-DIO: 8	M: 20.0 D: 2.0

* When the heat-side or cool-side integral time is set to zero for Heat/Cool PID control, PD action will take place for both heat-side and cool-side.

Continued on the next page.

7. COMMUNICATION DATA LIST

Continued from the previous page.

Extension number	Communication item	Attribute	Data range	Correspondence module and occupation CH	Factory set value
133 ⋮ 139	Unused	—	—	—	—
140	Heater break determination point	R/W	0.0 to 100.0 % of HBA set value (0.0: Heater break determination is invalid) If there is no current transformer (CT) or CT is assigned to "0: None," set to RO (Only reading data is possible). If Heater break alarm (HBA) corresponds to "0: Type A," set to RO (Only reading data is possible).	Z-TIO: 4	30.0
141	Heater melting determination point	R/W	0.0 to 100.0 % of HBA set value (0.0: Heater melting determination is invalid) If there is no current transformer (CT) or CT is assigned to "0: None," set to RO (Only reading data is possible). If Heater break alarm (HBA) corresponds to "0: Type A," set to RO (Only reading data is possible).	Z-TIO: 4	30.0
142	PV ratio	R/W	0.500 to 1.500	Z-TIO: 4	1.000
143	PV low input cut-off	R/W	0.00 to 25.00 % of input span If the Input square root extraction corresponds to "0: Unused," set to RO (Only reading data is possible).	Z-TIO: 4	0.00
144	Unused	—	—	—	—
145	Unused	—	—	—	—
146	Backup memory state monitor	RO	0: The content of the backup memory does not coincide with that of the RAM. 1: The content of the backup memory coincides with that of the RAM.	Z-TIO: 1 Z-DIO: 1	—
147	Logic output monitor	RO	Bit data Bit 0: Logic output 1 state Bit 1: Logic output 2 state Bit 2: Logic output 3 state Bit 3: Logic output 4 state Bit 4: Logic output 5 state Bit 5: Logic output 6 state Bit 6: Logic output 7 state Bit 7: Logic output 8 state Bit 8 to Bit 15: Unused Data 0: OFF 1: ON [Decimal number: 0 to 255]	Z-TIO: 1	—
148	RS bias Cascade control: Cascade bias Ratio setting: Ratio setting bias	R/W	-Input span to +Input span Varies with the setting of the decimal point position selection.	Z-TIO: 4	0 (0.0)
149	RS digital filter Cascade control: Cascade digital filter Ratio setting: Ratio setting digital filter	R/W	0.0 to 100.0 seconds (0.0: Unused)	Z-TIO: 4	0.0
150	RS ratio Cascade control: Cascade ratio Ratio setting: Ratio setting ratio	R/W	0.001 to 9.999	Z-TIO: 4	1.000
151	Unused	—	—	—	—

Continued on the next page.

Continued from the previous page.

Extension number	Communication item	Attribute	Data range	Correspondence module and occupation CH	Factory set value
152	Unused	—	—	—	—
153	Unused	—	—	—	—
154	Output distribution selection	R/W	0: Control output 1: Distribution output	Z-TIO: 4	0
155	Output distribution bias	R/W	–100.0 to +100.0 %	Z-TIO: 4	0.0
156	Output distribution ratio	R/W	–9.999 to +9.999	Z-TIO: 4	1.000
157	DO output distribution selection	R/W	0: DO output 1: Distribution output	Z-DIO: 8	0
158	DO output distribution bias	R/W	–100.0 to +100.0 %	Z-DIO: 8	0.0
159	DO output distribution ratio	R/W	–9.999 to +9.999	Z-DIO: 8	1.000
160	Display unit	R/W	0: °C 1: °F Use to select the temperature unit for thermocouple (TC) and RTD inputs.	Z-TIO: 4	Based on model code. When not specifying: 0
161	Input scale high	R/W	TC/RTD inputs: Input scale low to Maximum value of the selected input range Voltage (V)/Current (I) inputs: –19999 to +19999 (However, a span is 20000 or less.) Varies with the setting of the decimal point position selection.	Z-TIO: 4	TC/RTD: Maximum value of the selected input range V/I: 100.0
162	Input scale low	R/W	TC/RTD inputs: Minimum value of the selected input range to Input scale high Voltage (V)/Current (I) inputs: –19999 to +19999 (However, a span is 20000 or less.) Varies with the setting of the decimal point position selection.	Z-TIO: 4	TC/RTD: Minimum value of the selected input range V/I: 0.0
163	Input error determination point (high)	R/W	Input error determination point (low limit) to (Input range high + 5 % of input span) Varies with the setting of the decimal point position selection.	Z-TIO: 4	Input range high + (5 % of input span)
164	Input error determination point (low)	R/W	(Input range low – 5 % of input span) to Input error determination point (high limit) Varies with the setting of the decimal point position selection.	Z-TIO: 4	Input range low – (5 % of input span)
165	Burnout direction	R/W	0: Upscale 1: Downscale Valid only when the TC input and voltage (low) input are selected.	Z-TIO: 4	0
166	Square root extraction	R/W	0: Unused 1: Used	Z-TIO: 4	0
167 ⋮ 170	Unused	—	—	—	—
171	DI function assignment	R/W	0 to 29 (Refer to page 96)	Z-DIO: 1	Based on model code. When not specifying: 0
172 ⋮ 179	Unused	—	—	—	—

Continued on the next page.

7. COMMUNICATION DATA LIST

Continued from the previous page.

Extension number	Communication item	Attribute	Data range	Correspondence module and occupation CH	Factory set value
180	Output assignment (Logic output selection function)	R/W	0: Control output 1: Logic output result 2: FAIL output	Z-TIO: 4	0
181 ⋮ 185	Unused	—	—	—	—
186	Energized/De-energized (Logic output selection function)	R/W	0: Energized 1: De-energized	Z-TIO: 4	0
187 ⋮ 199	Unused	—	—	—	—
200	Force ON of Event 1 action	R/W	Bit data Bit 0: Event output turned on at input error occurrence Bit 1: Event output turned on in manual mode Bit 2: Event output turned on during the autotuning (AT) function is being executed Bit 3: Event output turned on during the setting change rate limiter is being operated Bit 4 to Bit 15: Unused Data 0: Invalid 1: Valid [Decimal number: 0 to 15]	Z-TIO: 4	0
201	Event 1 channel setting	R/W	1: Channel 1 2: Channel 2 3: Channel 3 4: Channel 4 This function is valid when "deviation between channels" is selected	Z-TIO: 4	1
202	Event 1 interlock	R/W	0: Unused 1: Used	Z-TIO: 4	0
203	Event 1 delay timer	R/W	0 to 18000 seconds	Z-TIO: 4	0
204	Force ON of Event 2 action	R/W	Bit data Bit 0: Event output turned on at input error occurrence Bit 1: Event output turned on in manual mode Bit 2: Event output turned on during the autotuning (AT) function is being executed Bit 3: Event output turned on during the setting change rate limiter is being operated Bit 4 to Bit 15: Unused Data 0: Invalid 1: Valid [Decimal number: 0 to 15]	Z-TIO: 4	0
205	Event 2 channel setting	R/W	1: Channel 1 2: Channel 2 3: Channel 3 4: Channel 4 This function is valid when "deviation between channels" is selected	Z-TIO: 4	1
206	Event 2 interlock	R/W	0: Unused 1: Used	Z-TIO: 4	0

Continued on the next page.

Continued from the previous page.

Extension number	Communication item	Attribute	Data range	Correspondence module and occupation CH	Factory set value
207	Event 2 delay timer	R/W	0 to 18000 seconds	Z-TIO: 4	0.0
208	Force ON of Event 3 action	R/W	Bit data Bit 0: Event output turned on at input error occurrence Bit 1: Event output turned on in manual mode Bit 2: Event output turned on during the autotuning (AT) function is being executed Bit 3: Event output turned on during the setting change rate limiter is being operated Bit 4 to Bit 15: Unused Data 0: Invalid 1: Valid [Decimal number: 0 to 15]	Z-TIO: 4	0
209	Event 3 channel setting	R/W	1: Channel 1 2: Channel 2 3: Channel 3 4: Channel 4 This function is valid when "deviation between channels" is selected	Z-TIO: 4	1
210	Event 3 interlock	R/W	0: Unused 1: Used	Z-TIO: 4	0
211	Event 3 delay timer	R/W	0 to 18000 seconds	Z-TIO: 4	0.0
212	Force ON of Event 4 action	R/W	Bit data Bit 0: Event output turned on at input error occurrence Bit 1: Event output turned on in manual mode Bit 2: Event output turned on during the autotuning (AT) function is being executed Bit 3: Event output turned on during the setting change rate limiter is being operated Bit 4 to Bit 15: Unused Data 0: Invalid 1: Valid [Decimal number: 0 to 15]	Z-TIO: 4	0
213	Event 4 channel setting	R/W	1: Channel 1 2: Channel 2 3: Channel 3 4: Channel 4 This function is valid when "deviation between channels" is selected	Z-TIO: 4	1
214	Event 4 interlock	R/W	0: Unused 1: Used	Z-TIO: 4	0
215	Event 4 delay timer	R/W	0 to 18000 seconds	Z-TIO: 4	0.0
216 ⋮ 219	Unused	—	—	—	—
220	CT ratio	R/W	0 to 9999	Z-TIO: 4	CTL-6-P-N: 800 CTL-12-S56 -10L-N: 1000

Continued on the next page.

7. COMMUNICATION DATA LIST

Continued from the previous page.

Extension number	Communication item	Attribute	Data range	Correspondence module and occupation CH	Factory set value
221	Heater break alarm (HBA) type	R/W	0: Heater break alarm 1 (HBA1) type A (Time-proportional control output) 1: Heater break alarm 1 (HBA1) type B (Continuous control output)	Z-TIO: 4	Set value is based on the Output type specified at ordering.
222	Number of heater break alarm (HBA) delay times	R/W	0 to 255 times	Z-TIO: 4	5
223	CT assignment	R/W	0: None 1: OUT1 2: OUT2 3: OUT3 4: OUT4	Z-TIO: 4	CH1: 1 CH2: 2 CH3: 3 CH4: 4 (for each Z-TIO module)
224 ⋮ 229	Unused	—	—	—	—
230	Hot/Cold start	R/W	0: Hot start 1 1: Hot start 2 2: Cold start	Z-TIO: 4	0
231 ⋮ 233	Unused	—	—	—	—
234	SV tracking	R/W	0: Unused 1: Used	Z-TIO: 4	1
235	MV transfer function [Action taken when changed to Manual mode from Auto mode]	R/W	0: MV in Auto mode is used. [Balanceless-bumpless function] 1: MV in previous Manual mode is used.	Z-TIO: 4	0
236	Start determination point	R/W	0 (0.0) to Input span (The unit is the same as input value.) 0 (0.0): Action depending on the Hot/Cold start selection Varies with the setting of the decimal point position selection.	Z-TIO: 4	Based on specification
237	Unused	—	—	—	—
238	Unused	—	—	—	—
239	PV transfer function	R/W	0: Unused 1: Used	Z-TIO: 4	0
240	Integral/Derivative time decimal point position ♣	R/W	0: 1 second setting (No decimal place) 1: 0.1 seconds setting (One decimal place)	Z-TIO: 4	0
241	Derivative gain ♣	R/W	0.1 to 10.0	Z-TIO: 4	6.0
242	ON/OFF action differential gap (upper)	R/W	TC/RTD inputs: 0 (0.0) to Input span (Unit: °C [°F]) Varies with the setting of the decimal point position selection.	Z-TIO: 4	TC/RTD: 1 (1.0) V/I: 0.1
243	ON/OFF action differential gap (lower)	R/W	Voltage (V)/Current (I) inputs: 0.0 to 100.0 % of input span	Z-TIO: 4	TC/RTD: 1 (1.0) V/I: 0.1
244	Action (high) at input error	R/W	0: Normal control	Z-TIO: 4	0
245	Action (low) at input error	R/W	1: Manipulated output value at input error	Z-TIO: 4	0

Continued on the next page.

Continued from the previous page.

Extension number	Communication item	Attribute	Data range	Correspondence module and occupation CH	Factory set value
246	Manipulated output value at input error	R/W	-105.0 to +105.0 % Actual output values become those restricted by the output limiter. Position proportioning PID control: If there is no feedback resistance (FBR) input or the feedback resistance (FBR) input is disconnected, an action taken when abnormal is in accordance with the value action setting during STOP.	Z-TIO: 4	0.0
247	Output change rate limiter (up) [heat-side] ♣	R/W	0.0 to 100.0 % of manipulated output/seconds (0.0: OFF)	Z-TIO: 4	0.0
248	Output change rate limiter (down) [heat-side] ♣	R/W	Becomes invalid when in Position proportioning PID control.	Z-TIO: 4	0.0
249	Unused	—	—	—	—
250	Unused	—	—	—	—
251	Derivative action ♣	R/W	0: Measured value derivative 1: Deviation derivative	Z-TIO: 4	0
252	Undershoot suppression factor ♣	R/W	0.000 to 1.000	Z-TIO: 4	Water cooling: 0.100 Air cooling: 0.250 Cooling gain linear type: 1.000
253	Unused	—	—	—	—
254	Output limiter high [cool-side] ♣	R/W	Output limiter low [cool-side] to 105.0 %	Z-TIO: 4	105.0
255	Output limiter low [cool-side] ♣	R/W	-5.0 % to Output limiter high [cool-side]	Z-TIO: 4	-5.0
256	Output change rate limiter (up) [cool-side] ♣	R/W	0.0 to 100.0 % of manipulated output/seconds (0.0: OFF)	Z-TIO: 4	0.0
257	Output change rate limiter (down) [cool-side] ♣	R/W	Becomes invalid when in Position proportioning PID control.	Z-TIO: 4	0.0
258	Manipulated output value at STOP mode [heat-side] ♣	R/W	-5.0 to +105.0 % Position proportioning PID control: Only when there is feedback resistance (FBR) input and it does not break, the manipulated output value [heat-side] at STOP is output.	Z-TIO: 4	-5.0
259	Manipulated output value at STOP mode [cool-side] ♣	R/W		Z-TIO: 4	-5.0
260	Action at feedback resistance (FBR) input break ♣	R/W	0: Action depending on the valve action at STOP 1: Control action continued	Z-TIO: 4	0
261	Unused	—	—	—	—
262	Open/Close output neutral zone ♣	R/W	0.1 to 10.0 % of output	Z-TIO: 4	2.0
263	Unused	—	—	—	—
264	Feedback adjustment ♣	R/W	0: Adjustment end 1: Open-side adjustment start 2: Close-side adjustment start	Z-TIO: 4	—
265	Integrated output limiter ♣	R/W	0.0 to 200.0 % of control motor time (0.0: OFF) Becomes invalid when there is feedback resistance (FBR) input.	Z-TIO: 4	150.0
266	Control motor time ♣	R/W	5 to 1000 seconds	Z-TIO: 4	10

Continued on the next page.

7. COMMUNICATION DATA LIST

Continued from the previous page.

Extension number	Communication item	Attribute	Data range	Correspondence module and occupation CH	Factory set value
267	Valve action at STOP ♣	R/W	0: Close-side output OFF, Open-side output OFF 1: Close-side output ON, Open-side output OFF 2: Close-side output OFF, Open-side output ON Becomes valid when there is no feedback resistance (FBR) input or the feedback resistance (FBR) input is disconnected.	Z-TIO: 4	0
268	Unused	—	—	—	—
269	Unused	—	—	—	—
270	AT bias ♣	R/W	–Input span to +Input span Varies with the setting of the decimal point position selection.	Z-TIO: 4	0 (0.0)
271	AT cycles ♣	R/W	0: 1.5 cycles 1: 2.0 cycles 2: 2.5 cycles 3: 3.0 cycles	Z-TIO: 4	1
272	AT differential gap time ♣	R/W	0.0 to 50.0 seconds	Z-TIO: 4	10.0
273	Output value with AT turned on ♣	R/W	Output value with AT turned off to +105.0 % Actual output values become those restricted by the output limiter. Position proportioning PID control: Becomes valid only when there is feedback resistance (FBR) input and it does not break (high limit of feedback resistance input at AT).	Z-TIO: 4	105.0
274	Output value with AT turned off ♣	R/W	–105.0 % to Output value with AT turned on Actual output values become those restricted by the output limiter. Position proportioning PID control: Becomes valid only when there is feedback resistance (FBR) input and it does not break (low limit of feedback resistance input at AT).	Z-TIO: 4	–105.0
275	Proportional band adjusting factor [heat-side] ♣	R/W	0.01 to 10.00 times	Z-TIO: 4	1.00
276	Integral time adjusting factor [heat-side] ♣	R/W		Z-TIO: 4	1.00
277	Derivative time adjusting factor [heat-side] ♣	R/W		Z-TIO: 4	1.00
278	Proportional band adjusting factor [cool-side] ♣	R/W		Z-TIO: 4	1.00
279	Integral time adjusting factor [cool-side] ♣	R/W		Z-TIO: 4	1.00
280	Derivative time adjusting factor [cool-side] ♣	R/W		Z-TIO: 4	1.00
281	Proportional band limiter (high) [heat-side] ♣	R/W	TC/RTD inputs: 0 (0.0) to Input span (Unit: °C [°F]) Varies with the setting of the decimal point position selection.	Z-TIO: 4	TC/RTD: Input span V/I: 1000.0
282	Proportional band limiter (low) [heat-side] ♣	R/W	Voltage (V)/Current (I) inputs: 0.0 to 1000.0 % of input span 0 (0.0): ON/OFF action ON/OFF action for both heat and cool actions in case of a Heat/Cool PID control type.	Z-TIO: 4	TC/RTD: 0 (0.0) V/I: 0.0

Continued on the next page.

Continued from the previous page.

Extension number	Communication item	Attribute	Data range	Correspondence module and occupation CH	Factory set value
283	Integral time limiter (high) [heat-side] ♣	R/W	PID control or Heat/Cool PID control: 0 to 3600 seconds or 0.0 to 1999.9 seconds	Z-TIO: 4	3600
284	Integral time limiter (low) [heat-side] ♣	R/W	Position proportioning PID control: 1 to 3600 seconds or 0.1 to 1999.9 seconds Varies with the setting of the Integral/Derivative time decimal point position selection.	Z-TIO: 4	PID control, Heat/Cool PID control: 0 Position proportioning PID control: 1
285	Derivative time limiter (high) [heat-side] ♣	R/W	0 to 3600 seconds or 0.0 to 1999.9 seconds Varies with the setting of the Integral/Derivative time decimal point position selection.	Z-TIO: 4	3600
286	Derivative time limiter (low) [heat-side] ♣	R/W		Z-TIO: 4	0
287	Proportional band limiter (high) [cool-side] ♣	R/W	TC/RTD inputs: 1 to Input span or 0.1 to Input span (Unit: °C [°F]) Varies with the setting of the decimal point position selection.	Z-TIO: 4	TC/RTD: Input span V/I: 1000.0
288	Proportional band limiter (low) [cool-side] ♣	R/W	Voltage (V)/Current (I) inputs: 0.1 to 1000.0 % of input span	Z-TIO: 4	TC/RTD: 1 (0.1) V/I: 0.1
289	Integral time limiter (high) [cool-side] ♣	R/W	0 to 3600 seconds or 0.0 to 1999.9 seconds Varies with the setting of the Integral/Derivative time decimal point position selection.	Z-TIO: 4	3600
290	Integral time limiter (low) [cool-side] ♣	R/W	If control is other than Heat/Cool PID control, set to RO (Only reading data is possible).	Z-TIO: 4	0
291	Derivative time limiter (high) [cool-side] ♣	R/W	0 to 3600 seconds or 0.0 to 1999.9 seconds Varies with the setting of the Integral/Derivative time decimal point position selection.	Z-TIO: 4	3600
292	Derivative time limiter (low) [cool-side] ♣	R/W	If control is other than Heat/Cool PID control, set to RO (Only reading data is possible).	Z-TIO: 4	0
293 ⋮ 299	Unused	—	—	—	—
300	Setting change rate limiter unit time	R/W	1 to 3600 seconds	Z-TIO: 4	60
301	Soak time unit	R/W	0: 0 to 5999 minutes [0 hours 00 minutes to 99 hours 59 minutes] 1: 0 to 11999 seconds [0 minutes 00 seconds to 199 minutes 59 seconds] Set the data range of Memory area soak time monitor and Area soak time.	Z-TIO: 4	1
302 ⋮ 340	Unused	—	—	—	—
341	Integrated operating time monitor	RO	0 to 19999 hours	Z-TIO: 1 Z-DIO: 1	—
342	Holding peak value ambient temperature monitor	RO	-10.0 to +100.0 °C (14.0 to 212.0 °F)	Z-TIO: 4	—
343 ⋮ 349	Unused	—	—	—	—

Continued on the next page.

7. COMMUNICATION DATA LIST

Continued from the previous page.

Extension number	Communication item	Attribute	Data range	Correspondence module and occupation CH	Factory set value
350	Startup tuning (ST)	R/W	0: ST unused 1: Execute once * 2: Execute always * When the startup tuning is finished, the setting will automatically returns to "0: ST unused." The Startup tuning (ST) function is activated according to the ST start condition selected. If control is other than Position proportioning PID control, set to RO (Only reading data is possible).	Z-TIO: 4	0
351	ST proportional band adjusting factor	R/W	0.01 to 10.00 times	Z-TIO: 4	1.00
352	ST integral time adjusting factor	R/W		Z-TIO: 4	1.00
353	ST derivative time adjusting factor	R/W		Z-TIO: 4	1.00
354	ST start condition	R/W	0: Activate the Sstartup tuning (ST) function when the power is turned on; when transferred from STOP to RUN; or when the Set value (SV) is changed. 1: Activate the Startup tuning (ST) function when the power is turned on; or when transferred from STOP to RUN. 2: Activate the Sstartup tuning (ST) function when the Set value (SV) is changed.	Z-TIO: 4	0
355	Automatic temperature rise group	R/W	0 to 16 (0: Automatic temperature rise function OFF)	Z-TIO: 4	0
356	Automatic temperature rise learning	R/W	0: Unused 1: Learning * * When the automatic temperature rise learning is finished, the setting will automatically returns to "0: Unused." If the Automatic temperature rise group corresponds to "0: Automatic temperature rise function OFF," set to RO (Only reading data is possible).	Z-TIO: 4	0
357	Automatic temperature rise dead time	R/W	0.1 to 1999.9 seconds	Z-TIO: 4	10.0
358	Automatic temperature rise gradient data	R/W	1 (0.1) to Input span/minutes Varies with the setting of the decimal point position selection.	Z-TIO: 4	1 (1.0)
359	Unused	—	—	—	—
360	EDS mode (for disturbance 1)	R/W	0: No function 1: EDS function mode 2: Learning mode 3: Tuning mode EDS function: External disturbance suppression function	Z-TIO: 4	0
361	EDS mode (for disturbance 2)	R/W		Z-TIO: 4	0
362	EDS value 1 (for disturbance 1)	R/W	-100.0 to +100.0 %	Z-TIO: 4	0.0
363	EDS value 1 (for disturbance 2)	R/W		Z-TIO: 4	0.0
364	EDS value 2 (for disturbance 1)	R/W	-100.0 to +100.0 %	Z-TIO: 4	0.0
365	EDS value 2 (for disturbance 2)	R/W		Z-TIO: 4	0.0

Continued on the next page.

Continued from the previous page.

Extension number	Communication item	Attribute	Data range	Correspondence module and occupation CH	Factory set value
366	EDS transfer time (for disturbance 1)	R/W	0 to 3600 seconds or 0.0 to 1999.9 seconds	Z-TIO: 4	0
367	EDS transfer time (for disturbance 2)	R/W		Z-TIO: 4	0
368	EDS action time (for disturbance 1)	R/W	1 to 3600 seconds	Z-TIO: 4	600
369	EDS action time (for disturbance 2)	R/W		Z-TIO: 4	600
370	EDS action wait time (for disturbance 1)	R/W	0.0 to 600.0 seconds	Z-TIO: 4	0.0
371	EDS action wait time (for disturbance 2)	R/W		Z-TIO: 4	0.0
372	EDS value learning times	R/W	0 to 10 times (0: No learning mode)	Z-TIO: 4	1
373	EDS start signal	R/W	0: EDS start signal OFF 1: EDS start signal ON (for disturbance 1) 2: EDS start signal ON (for disturbance 2)	Z-TIO: 4	0
374	EDS transfer time decimal point position	R/W	0: 1 second setting (No decimal place) 1: 0.1 seconds setting (One decimal place)	Z-TIO: 4	0
375	Output average processing time for EDS	R/W	0.1 to 200.0 seconds	Z-TIO: 4	1.0
376	Responsive action trigger point for EDS	R/W	TC/RTD inputs: 0 (0.0) to Input span (Unit: °C [°F]) Voltage (V)/Current (I) inputs: 0.0 to Input span (Unit: %) Varies with the setting of the decimal point position selection.	Z-TIO: 4	TC/RTD: 1 (1.0) V/I: 1.0
377	Operation mode assignment 1 (Logic output selection function) Logic output 1 to 4	R/W	0: No assignment 1: Operation mode (monitor, control) 2: Operation mode (monitor, event function, control) 3: Auto/Manual 4: Remote/Local 5: Unused (Do not set this one.)	Z-TIO: 4	0
378	Operation mode assignment 2 (Logic output selection function) Logic output 5 to 8	R/W		Z-TIO: 4	0
379	SV select function	R/W	0: Remote SV function 1: Cascade control function 2: Ratio setting function 3: Cascade control 2 function	Z-TIO: 4	0
380	Remote SV function master channel module address	R/W	-1 (Master channel is selected from itself) 0 to 99 (Master channel is selected from other modules)	Z-TIO: 4	-1
381	Remote SV function master channel selection	R/W	1 to 99	Z-TIO: 4	1
382	Output distribution master channel module address	R/W	-1 (Master channel is selected from itself) 0 to 99 (Master channel is selected from other modules)	Z-TIO: 4	-1
383	Output distribution master channel selection	R/W	1 to 99	Z-TIO: 4	1
384	Address of interacting modules	R/W	-1 (Interact with its own module address) 0 to 99 (Interact with the addresses of other modules)	Z-TIO: 4	-1

Continued on the next page.

7. COMMUNICATION DATA LIST

Continued from the previous page.

Extension number	Communication item	Attribute	Data range	Correspondence module and occupation CH	Factory set value
385	Channel selection of interacting modules	R/W	1 to 99 Becomes valid when the selected module is "Z-TIO module."	Z-TIO: 4	1
386	Selection switch of interacting modules	R/W	Bit data Bit 0: Memory area number Bit 1: Operation mode Bit 2: Auto/Manual Bit 3: Remote/Local Bit 4: EDS start signal Bit 5: Interlock release Bit 6: Suspension of area soak time Bit 7 to Bit 15: Unused Data 0: No interaction 1: Interact with other channels [Decimal number: 0 to 127]	Z-TIO: 4	0
387	Control RUN/STOP holding setting	R/W	0: Not holding (STOP start) 1: Holding (RUN/STOP hold)	Z-TIO: 1 Z-DIO: 1	1
388	Interval time	R/W	0 to 250 ms	Z-TIO: 1 Z-DIO: 1	10
389	Unused	—	—	—	—
390	Memory area setting signal	R/W	0: Valid 1: Invalid	Z-DIO: 1	1
391	DO signal assignment module address 1	R/W	-1, 0 to 99 When "-1" is selected, all of the signals of the same type (except temperature rise completion and DO manual output value) are OR-operated and produced as outputs from DO.	Z-DIO: 1	-1
392	DO signal assignment module address 2	R/W		Z-DIO: 1	-1
393	DO output assignment 1 [DO1 to DO4]	R/W	0 to 13 (Refer to page 97)	Z-DIO: 1	Based on model code. When not specifying: 0
394	DO output assignment 2 [DO5 to DO8]	R/W		Z-DIO: 1	Based on model code. When not specifying: 0
395	DO energized/de-energized	R/W	0: Energized 1: De-energized	Z-DIO: 8	0
396	DO output distribution master channel module address	R/W	-1 (Master channel is selected from itself) 0 to 99 (Master channel is selected from other modules)	Z-DIO: 8	-1
397	DO output distribution master channel selection	R/W	1 to 99	Z-DIO: 8	1
398	DO manipulated output value (MV) at STOP mode	R/W	-5.0 to +105.0 %	Z-DIO: 8	-5.0
399	DO output limiter (high)	R/W	DO output limiter (low) to 105.0 %	Z-DIO: 8	105.0
400	DO output limiter (low)	R/W	-5.0 % to DO output limiter (high)	Z-DIO: 8	-5.0
401 ⋮ 499	Unused	—	—	—	—

Continued on the next page.

Continued from the previous page.

Extension number	Communication item	Attribute	Data range	Correspondence module and occupation CH	Factory set value
500	Action mode selection	R/W	Bit data Bit 0: Address setting ¹ Bit 1 to Bit 15: Unused Data 0: Continuous setting 1: Free setting [Decimal number: 0 to 1]	COM-JC: 1	1
501	Transmission wait time of controller communication	R/W	0 to 100 ms	COM-JC: 1	0
502	Type of connected controller	R/W	0 to 65535 4: Z-TIO 5: Z-DIO	COM-JC: 31	Note
503	Address setting of connected controller	R/W	0 to 99 0: No connected controller 1 to 16: Z-TIO 17 to 32: Z-DIO 33 to 99: Reserved	COM-JC: 31	1 to 31
504	State of connected controller	RO	Bit data Bit 0: Presence or absence of controller Bit 1: Presence or absence of abnormal response Bit 2 to Bit 15: Unused Data 0: Absence 1: Presence [Decimal number: 0 to 3]	COM-JC: 31	—
505	Automatic acquisition of controller address ²	R/W	0: Do not execute the automatic acquisition 1: Execute the automatic acquisition * * Automatically reverts to 0 after automatic acquisition ends.	COM-JC: 1	0
506 ⋮ 511	Unused	—	—	—	—

 COM-JC data.

Note: When controller address 1 to 16: 4
When controller address 17 to 32: 5

¹ Address setting

Set the controller recognition to be made at the time of power-up.

- In case of continuous setting, controller recognition is started from CH1 and according to the No. 503 Address setting of the connected controller. Address is not recognized when no response is received from the controller or from on and after the CH No. where set value is zero.
- In case of free setting, regardless of the number of controllers connected, controller recognition is made sequentially from CH1, according to the No. 503 Address setting of connected controller. Recognizing action continues even if no response is received from the controller. For this reason, free setting needs longer time than continuous setting till recognition is completed.
If a set value "0" is detected, addresses at and after this CH No. are not recognized.

² After having set "1: Execute the automatic acquisition," power off the instrument, and power up again. Controller addresses are automatically acquired. (No.503 Address setting of connected controller is done automatically.) In case of automatic acquisition, recognition is made sequentially from the controller address 1. Recognition continues until 31 addresses are acquired or until controller address 99 is verified. At a completion of the recognition, recognized controller addresses are automatically set to the No.503 Address setting of connected controller.

Table 1: DI assignment table

Set value	DI1	DI2	DI3	DI4	DI5	DI6	DI7	DI8	
0	No assignment								
1	Memory area transfer (1 to 8) ¹			Area set ²		Operation mode ³		Interlock release	
2								AUTO/MAN ⁴	
3								REM/LOC ⁴	
4								EDS start signal 1	
5								Soak stop	
6								RUN/STOP ⁴	
7								REM/LOC ⁴	
8								EDS start signal 1	
9								Soak stop	
10								RUN/STOP ⁴	
11								EDS start signal 1	
12								Soak stop	
13								RUN/STOP ⁴	
14								EDS start signal 1	
15								Soak stop	
16								RUN/STOP ⁴	
17	EDS start signal 1								
18	Soak stop								
19	RUN/STOP ⁴								
20	EDS start signal 1								
21	Soak stop								
22	RUN/STOP ⁴								
23	EDS start signal 1								
24	Soak stop								
25	RUN/STOP ⁴								
26	Memory area transfer (1, 2) ¹	Area set ²	Interlock release	RUN/STOP ⁴	AUTO/MAN ⁴	REM/LOC ⁴	Operation mode ³		
27	Memory area transfer (1 to 8) ¹			Area set ²	Operation mode ³			EDS start signal 1	EDS start signal 2
28	Memory area transfer (1, 2) ¹	Area set ²	Interlock release	RUN/STOP ⁴	AUTO/MAN ⁴	REM/LOC ⁴	EDS start signal 1	EDS start signal 2	
29	EDS start signal 1	EDS start signal 2	Interlock release	RUN/STOP ⁴	AUTO/MAN ⁴	REM/LOC ⁴	Operation mode ³		

RUN/STOP: RUN/STOP transfer (Contact closed: RUN)
 AUTO/MAN: Auto/Manual transfer (Contact closed: Manual mode)
 REM/LOC: Remote/Local transfer (Contact closed: Remote mode)
 Interlock release (Contact closed: Interlock release)
 EDS start signal 1 (Contact closed: EDS start signal ON [for disturbance 1])
 EDS start signal 2 (Contact closed: EDS start signal ON [for disturbance 2])
 Soak stop (Contact closed: Soak stop)

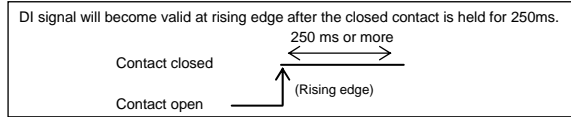

¹ Memory area transfer (x: Contact open - : Contact closed)

	Memory area number							
	1	2	3	4	5	6	7	8
DI1	x	-	x	-	x	-	x	-
DI2	x	x	-	-	x	x	-	-
DI3	x	x	x	x	-	-	-	-

² Area set becomes invalid prior to factory shipment.

³ Operation mode transfer (x: Contact open - : Contact closed)

	Operation mode			
	Unused	Monitor	Monitor + Event function	Control
DI5 (DI7)	x	-	x	-
DI6 (DI8)	x	x	-	-

⁴ Actual device states (AUTO/MAN, REM/LOC, RUN/STOP)

	DI-switched state	Communication-switched state	Actual device state
Auto/Manual transfer ^a (AUTO/MAN)	Manual (Contact closed)	Manual → Auto	Manual mode
		Auto → Manual	
	Auto (Contact open)	Manual → Auto	Auto mode
		Auto → Manual	
Remote/Local transfer ^a (REM/LOC)	Remote (Contact closed)	Remote → Local	Remote mode
		Local → Remote	
	Local (Contact open)	Remote → Local	Local mode
		Local → Remote	
RUN/STOP ^b	RUN (Contact closed)	STOP → RUN	RUN
		RUN → STOP	
	STOP (Contact open)	STOP → RUN	STOP
		RUN → STOP	

^a Device state when AUTO/MAN or REM/LOC assigned to DI is set so that the Z-TIO module and Z-DIO module are linked using the Master-slave mode of the Z-TIO module.

^b STOP of RUN/STOP switching is given priority regardless of communication or DI switching.

- Priority of Memory area transfer [When Area set is not effective] Ttransfer by DI has priority over the transfer by communication.

[When Area set is not effective] Regardless of transfer method (DI or communication), the last set data has priority.

- Priority of Operation mode transfer Ttransfer by DI has priority over the transfer by communication.

Table 2: DO assignment table

[DO1 to DO4]

Set value	DO1	DO2	DO3	DO4
0	No assignment			
1	DO1 manual output	DO2 manual output	DO3 manual output	DO4 manual output
2	Event 1 comprehensive output ¹	Event 2 comprehensive output ²	Event 3 comprehensive output ³	Event 4 comprehensive output ⁴
3	Event 1 (CH1)	Event 2 (CH1)	Event 3 (CH1)	Event 4 (CH1)
4	Event 1 (CH2)	Event 2 (CH2)	Event 3 (CH2)	Event 4 (CH2)
5	Event 1 (CH3)	Event 2 (CH3)	Event 3 (CH3)	Event 4 (CH3)
6	Event 1 (CH4)	Event 2 (CH4)	Event 3 (CH4)	Event 4 (CH4)
7	Event 1 (CH1)	Event 1 (CH2)	Event 1 (CH3)	Event 1 (CH4)
8	Event 2 (CH1)	Event 2 (CH2)	Event 2 (CH3)	Event 2 (CH4)
9	Event 3 (CH1)	Event 3 (CH2)	Event 3 (CH3)	Event 3 (CH4)
10	Event 4 (CH1)	Event 4 (CH2)	Event 4 (CH3)	Event 4 (CH4)
11	HBA (CH1)	HBA (CH2)	HBA (CH3)	HBA (CH4)
12	Burnout status (CH1)	Burnout status (CH2)	Burnout status (CH3)	Burnout status (CH4)
13	Temperature rise completion ⁵	HBA comprehensive output ⁶	Burnout state comprehensive output ⁷	DO4 manual output

[DO5 to DO8]

Set value	DO5	DO6	DO7	DO8
0	No assignment			
1	DO5 manual output	DO6 manual output	DO7 manual output	DO8 manual output
2	Event 1 comprehensive output ¹	Event 2 comprehensive output ²	Event 3 comprehensive output ³	Event 4 comprehensive output ⁴
3	Event 1 (CH1)	Event 2 (CH1)	Event 3 (CH1)	Event 4 (CH1)
4	Event 1 (CH2)	Event 2 (CH2)	Event 3 (CH2)	Event 4 (CH2)
5	Event 1 (CH3)	Event 2 (CH3)	Event 3 (CH3)	Event 4 (CH3)
6	Event 1 (CH4)	Event 2 (CH4)	Event 3 (CH4)	Event 4 (CH4)
7	Event 1 (CH1)	Event 1 (CH2)	Event 1 (CH3)	Event 1 (CH4)
8	Event 2 (CH1)	Event 2 (CH2)	Event 2 (CH3)	Event 2 (CH4)
9	Event 3 (CH1)	Event 3 (CH2)	Event 3 (CH3)	Event 3 (CH4)
10	Event 4 (CH1)	Event 4 (CH2)	Event 4 (CH3)	Event 4 (CH4)
11	HBA (CH1)	HBA (CH2)	HBA (CH3)	HBA (CH4)
12	Burnout status (CH1)	Burnout status (CH2)	Burnout status (CH3)	Burnout status (CH4)
13	Temperature rise completion ⁵	HBA comprehensive output ⁶	Burnout state comprehensive output ⁷	DO8 manual output

¹ Logical OR of Event 1 (ch1 to ch4)² Logical OR of Event 2 (ch1 to ch4)³ Logical OR of Event 3 (ch1 to ch4)⁴ Logical OR of Event 4 (ch1 to ch4)⁵ Temperature rise completion status (ON when temperature rise completion occurs for all channels for which event 3 is set to temperature rise completion.)⁶ Logical OR of HBA (ch1 to ch4)⁷ Logical OR of burnout state (ch1 to ch4)

8. USAGE EXAMPLE

This chapter describes a usage example of CC-Link communication.

8.1 Handling Procedures

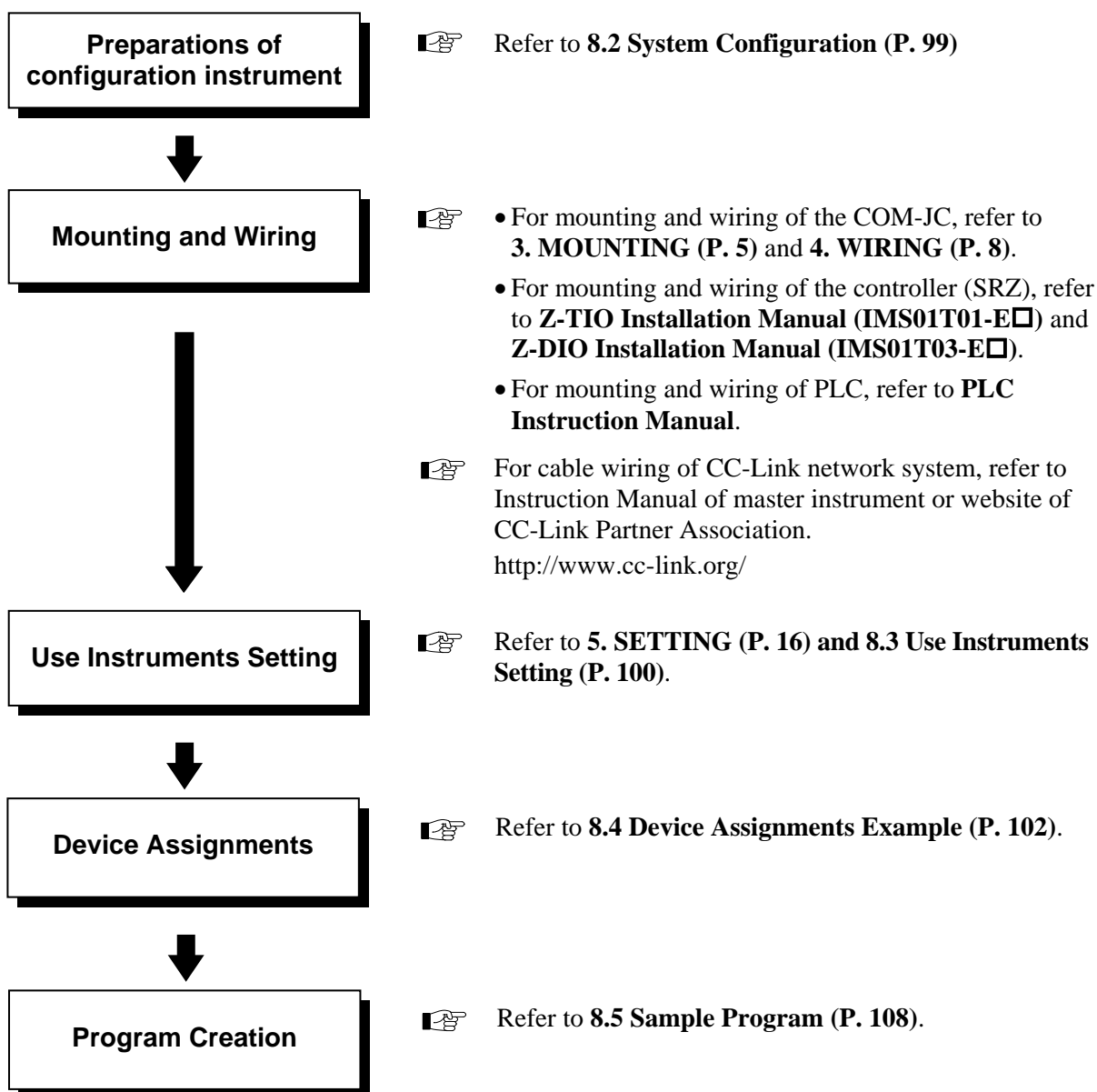

To avoid error at operation start-up, COM-JC must be powered on LAST (after the Controller, PLC, etc.).

8.2 System Configuration

In this usage example, described the following system configuration.

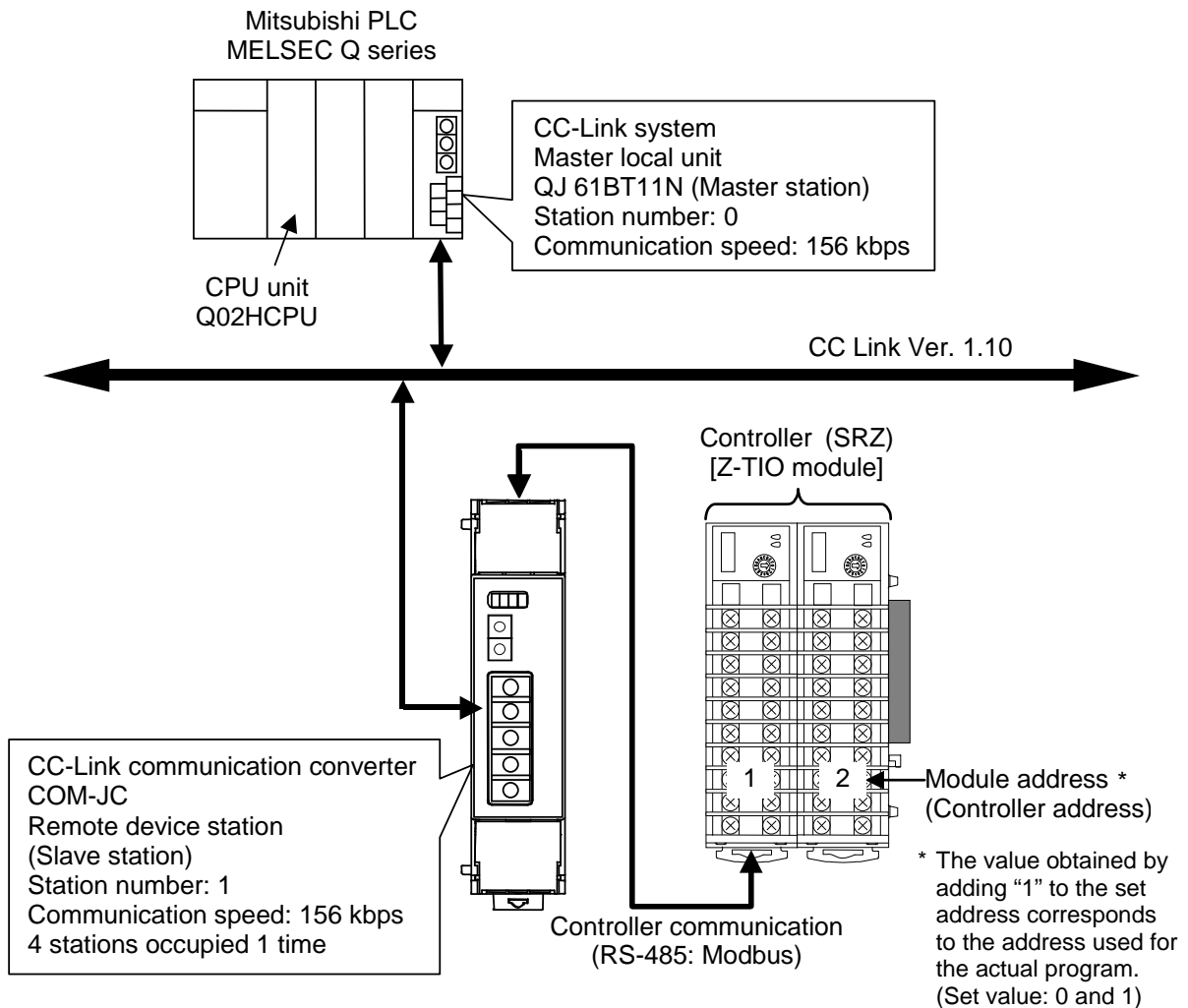

■ Use instruments

- CC-Link communication converter: COM-JC 1
- Controller (SRZ): Z-TIO module (4-channel type) 2
[Input type: Thermocouple K (0.0 to 400.0 °C)]
- Mitsubishi Electric PLC MELSEC Q series
 - CPU unit: Q02HCPU
 - CC-Link system master local unit: QJ61BT11N
- CC-Link dedicated cable Ver. 1.10
- COM-JC and controller connection cable

8.3 Use Instruments Setting

Set the PLC, COM-JC and controller as the following.

■ PLC setting

- ☞ For operating of CC-Link system master local unit QJ61BT11N and MELSEC sequencer programming software GX Developer, refer to PLC Instruction Manual.

[CC-Link system master local unit QJ61BT11N setting]

Setting item	Content
Station number	0
CC-Link communication speed	156 kbps

[Master station network parameter setting by GX Developer]

Setting item	Content
Number of boards in module	1
Start I/O number	0000
Operational settings	Parameter name: None Data link disorder station setting: Clear Case of CPU STOP setting: Refresh
Type	Master station
CC-Link mode setting	Remote net (Ver. 1 mode)
Total number of connected modules	1
Number of retries	5
Number of automatic return modules	1
Standby master station number	Blank
Operation specification when CPU is down	Stop
Scan mode specification	Asynchronous
Delay time setting	10 (500 μ s)
Station information [Number of COM-JC connection: 1 (Station number: 1)]	Station type: Remote device station Expanded cyclic setting: Single Number of occupied station: Occupies 4 stations Remote station points: 128 points Reserved/invalid station select: No setting Intelligent buffer select (word): No setting

[Automatic refresh parameter setting by GX Developer]

Setting item	Content
Remote input (RX) refresh device	X1000
Remote output (RY) refresh device	Y1000
Remote register (RW _r) refresh device	W0
Remote register (RW _w) refresh device	W100
Special relay (SB) refresh device	SB0
Special register (SW) refresh device	SW0

■ COM-JC setting

[CC-Link communication conditions]

- Number of occupied station/extended cyclic: 4 stations occupied 1 time (8 channels assignment)
- Station number: 1
- CC-Link communication speed: 156 kbps

[Controller communication condition]

- Controller communication speed: 19200 bps (Factory set value)

 For setting procedure, refer to **5. SETTING (P. 16)**.

■ Controller (Z-TIO module) setting

[Controller communication conditions]

- Device address: 1 and 2 (Set value: 0 and 1)
- Communication protocol: Modbus-RTU
- Communication speed: 19200 bps (Factory set value)
- Data bit configuration: Data 8-bit, Without parity bit, Stop 1-bit

 For setting procedure, refer to **Z-TIO Host Communication Quick Instruction Manual (IMS01T02-E□)**.

8.4 Device Assignments Example

According to the contents set by **8.3 Use Instruments Setting (P. 100)**, each device is assigned.

■ Assignment conditions

Station number of COM-JC:	1
Number of occupied station/extended cyclic:	4 stations occupied 1 time (8 channels assignment)
Automatic refresh device setting	
Remote input (RX) refresh device:	X1000
Remote output (RY) refresh device:	Y1000
Remote register (RW _r) refresh device:	W0
Remote register (RW _w) refresh device:	W100
Special relay (SB) refresh device:	SB0
Special register (SW) refresh device:	SW0

■ Remote input (RX) and Remote output (RY)

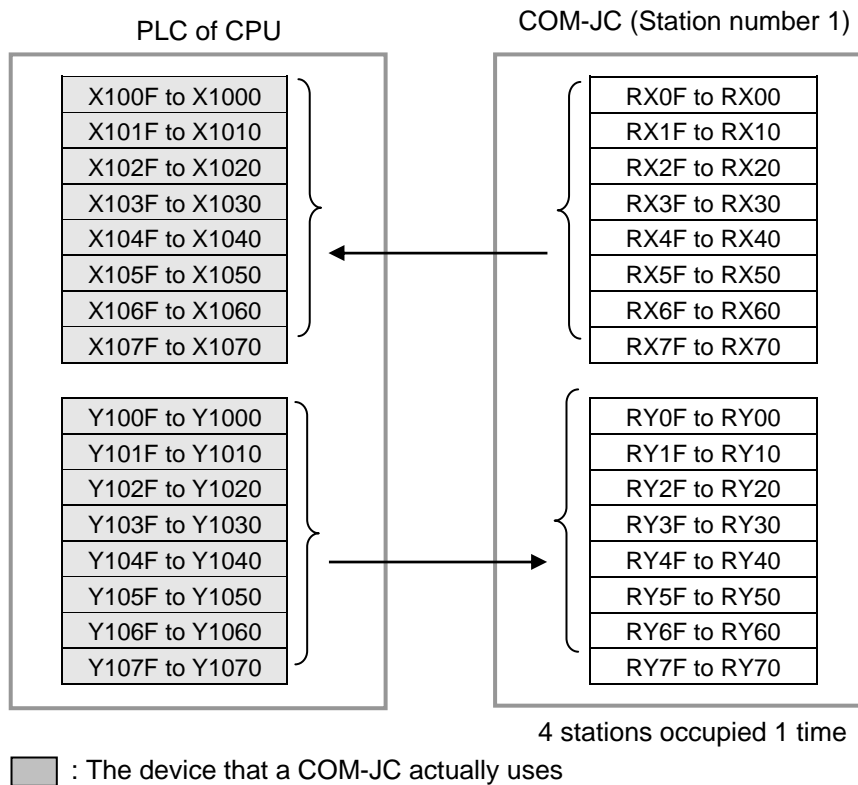

● Device assignment table of remote input (RX)

CPU device number	Communication item		Remote input (RX) address
X1000	CH1	Event 1 state	RX00
X1001		Event 2 state	RX01
X1002		Burnout state	RX02
X1003		Heater break alarm (HBA) state	RX03
X1004		PID/AT transfer	RX04
X1005	CH2	Event 1 state	RX05
X1006		Event 2 state	RX06
X1007		Burnout state	RX07
X1008		Heater break alarm (HBA) state	RX08
X1009		PID/AT transfer	RX09
X100A	Unused		RX0A
X100B	Unused		RX0B
X100C	Extended display completion		RX0C
X100D	Extended setting completion		RX0D
X100E	Unused		RX0E
X100F	Hardware error flag		RX0F
X1010 ⋮ X101F	Reserved		RX10 ⋮ RX1F
X1020	CH3	Event 1 state	RX20
X1021		Event 2 state	RX21
X1022		Burnout state	RX22
X1023		Heater break alarm (HBA) state	RX23
X1024		PID/AT transfer	RX24
X1025	CH4	Event 1 state	RX25
X1026		Event 2 state	RX26
X1027		Burnout state	RX27
X1028		Heater break alarm (HBA) state	RX28
X1029		PID/AT transfer	RX29
X102A	CH5	Event 1 state	RX2A
X102B		Event 2 state	RX2B
X102C		Burnout state	RX2C
X102D		Heater break alarm (HBA) state	RX2D
X102E		PID/AT transfer	RX2E
X102F	CH6	Event 1 state	RX2F
X1030		Event 2 state	RX30
X1031		Burnout state	RX31
X1032		Heater break alarm (HBA) state	RX32
X1033		PID/AT transfer	RX33
X1034	CH7	Event 1 state	RX34
X1035		Event 2 state	RX35
X1036		Burnout state	RX36
X1037		Heater break alarm (HBA) state	RX37
X1038		PID/AT transfer	RX38
X1039	CH8	Event 1 state	RX39
X103A		Event 2 state	RX3A

Continued on the next page.

Continued from the previous page.

CPU device number	Communication item		Remote input (RX) address
X103B	CH8	Burnout state	RX3B
X103C		Heater break alarm (HBA) state	RX3C
X103D		PID/AT transfer	RX3D
X103E ⋮ X106F	Unused		RX3E ⋮ RX6F
X1070 ⋮ X1077	Reserved		RX70 ⋮ RX77
X1078	Initialize data processing request flag		RX78
X1079	Initialize data setting completion flag		RX79
X107A	Error status flag		RX7A
X107B	Remote ready		RX7B
X107C ⋮ X107F	Reserved		RX7C ⋮ RX7F

● Device assignment table of remote output (RY)

CPU device number	Communication item		Remote output (RY) address
Y1000	Bit 0	Extension number for display	RY00
Y1001	Bit 1		RY01
Y1002	Bit 2		RY02
Y1003	Bit 3		RY03
Y1004	Bit 4		RY04
Y1005	Bit 5		RY05
Y1006	Bit 0	Extension number for setting	RY06
Y1007	Bit 1		RY07
Y1008	Bit 2		RY08
Y1009	Bit 3		RY09
Y100A	Bit 4		RY0A
Y100B	Bit 5		RY0B
Y100C	Extended display flag		RY0C
Y100D	Extended setting flag (Setting update flag)		RY0D
Y100E	Unused		RY0E
Y100F	RUN/STOP transfer		RY0F
Y1010	Bit 6	Extension number for display (Bit 9 to Bit 13: Unused)	RY10
Y1011	Bit 7		RY11
Y1012	Bit 8		RY12
Y1013	Bit 9		RY13
Y1014	Bit 10		RY14
Y1015	Bit 11		RY15

Continued on the next page.

Continued from the previous page.

CPU device number	Communication item		Remote output (RY) address	
Y1016	Bit 12	Extension number for display (Bit 9 to Bit 13: Unused)	RY16	
Y1017	Bit 13		RY17	
Y1018	Bit 6	Extension number for setting (Bit 9 to Bit 13: Unused)	RY18	
Y1019	Bit 7		RY19	
Y101A	Bit 8		RY1A	
Y101B	Bit 9		RY1B	
Y101C	Bit 10		RY1C	
Y101D	Bit 11		RY1D	
Y101E	Bit 12		RY1E	
Y101F	Bit 13		RY1F	
Y1020	Bit 0		Area number for display (Bit 4 to Bit 7: Unused)	RY20
Y1021	Bit 1			RY21
Y1022	Bit 2	RY22		
Y1023	Bit 3	RY23		
Y1024	Bit 4	RY24		
Y1025	Bit 5	RY25		
Y1026	Bit 6	RY26		
Y1027	Bit 7	RY27		
Y1028	Bit 0	Area number for setting (Bit 4 to Bit 7: Unused)	RY28	
Y1029	Bit 1		RY29	
Y102A	Bit 2		RY2A	
Y102B	Bit 3		RY2B	
Y102C	Bit 4		RY2C	
Y102D	Bit 5		RY2D	
Y102E	Bit 6		RY2E	
Y102F	Bit 7		RY2F	
Y1030 ⋮ Y106F	Unused		RY30 ⋮ RY6F	
Y1070 ⋮ Y1077	Reserved		RY70 ⋮ RY77	
Y1078	Initialize data processing completion flag		RY78	
Y1079	Initialize data setting request flag		RY79	
Y107A	Error reset request flag		RY7A	
Y107B ⋮ Y107F	Reserved		RY7B ⋮ RY7F	

■ Remote register (RWr, RWw)

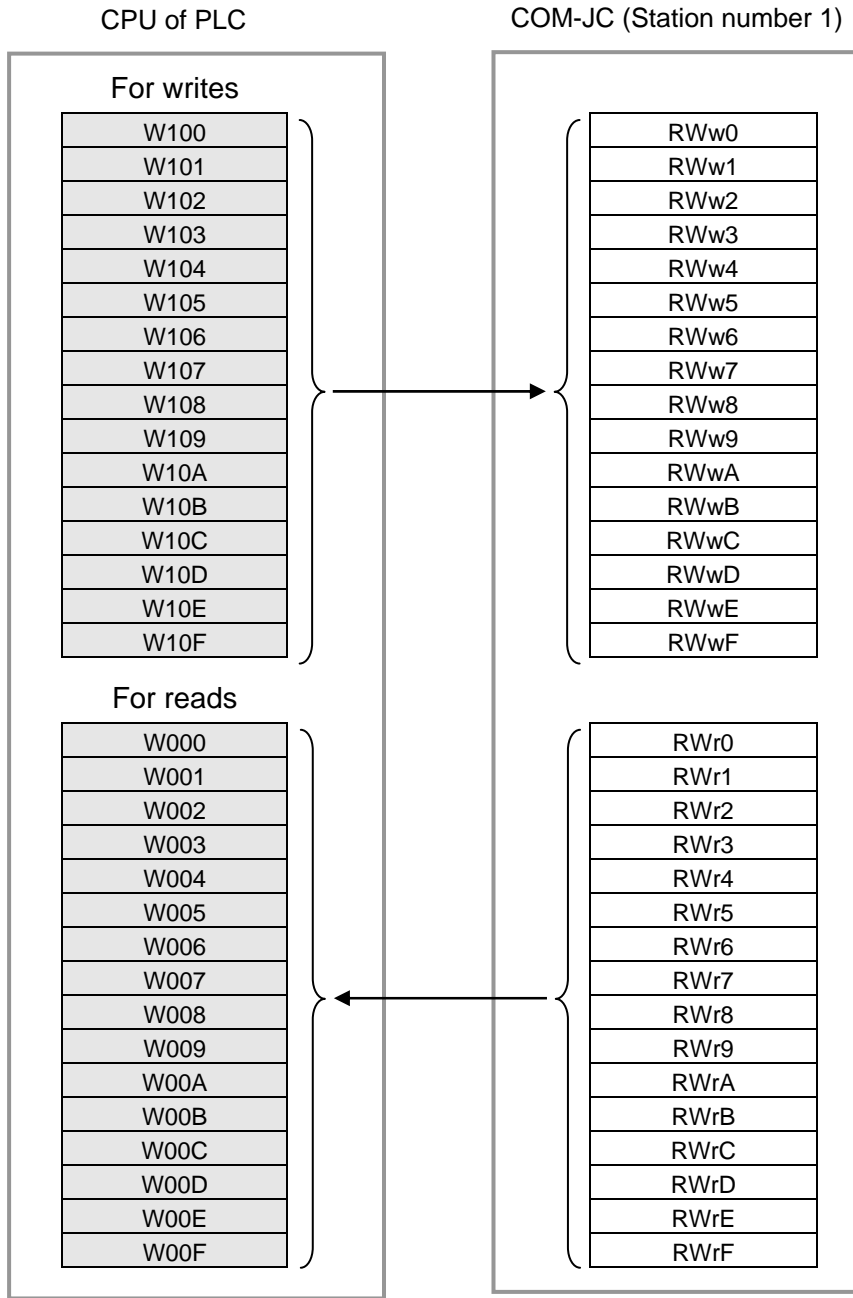

4 stations occupied 1 time

: The device that a COM-JC actually uses

● Device assignment table of remote register (RWw)

CPU device number	Communication item	Remote register (RWw) address
W100	Set value (SV) of CH1 (Module address 1)	RWw0
W101	Set value (SV) of CH2 (Module address 1)	RWw1
W102	Set value (SV) of CH3 (Module address 1)	RWw2
W103	Set value (SV) of CH4 (Module address 1)	RWw3
W104	Set value (SV) of CH5 (Module address 2)	RWw4
W105	Set value (SV) of CH6 (Module address 2)	RWw5
W106	Set value (SV) of CH7 (Module address 2)	RWw6
W107	Set value (SV) of CH8 (Module address 2)	RWw7
W108	For extension area setting of CH1 (Module address 1)	RWw8
W109	For extension area setting of CH2 (Module address 1)	RWw9
W10A	For extension area setting of CH3 (Module address 1)	RWwA
W10B	For extension area setting of CH4 (Module address 1)	RWwB
W10C	For extension area setting of CH5 (Module address 2)	RWwC
W10D	For extension area setting of CH6 (Module address 2)	RWwD
W10E	For extension area setting of CH7 (Module address 2)	RWwE
W10F	For extension area setting of CH8 (Module address 2)	RWwF

● Device assignment table of remote register (RWr)

CPU device address	Communication item	Remote register (RWr) address
W000	Measured value (PV) of CH1 (Module address 1)	RWr0
W001	Measured value (PV) of CH2 (Module address 1)	RWr1
W002	Measured value (PV) of CH3 (Module address 1)	RWr2
W003	Measured value (PV) of CH4 (Module address 1)	RWr3
W004	Measured value (PV) of CH5 (Module address 2)	RWr4
W005	Measured value (PV) of CH6 (Module address 2)	RWr5
W006	Measured value (PV) of CH7 (Module address 2)	RWr6
W007	Measured value (PV) of CH8 (Module address 2)	RWr7
W008	For extension area display of CH1 (Module address 1)	RWr8
W009	For extension area display of CH2 (Module address 1)	RWr9
W00A	For extension area display of CH3 (Module address 1)	RWrA
W00B	For extension area display of CH4 (Module address 1)	RWrB
W00C	For extension area display of CH5 (Module address 2)	RWrC
W00D	For extension area display of CH6 (Module address 2)	RWrD
W00E	For extension area display of CH7 (Module address 2)	RWrE
W00F	For extension area display of CH8 (Module address 2)	RWrF

8.5 Sample Program

■ Program conditions

Station number of COM-JC:	1
Number of occupied station/extended cyclic:	4 stations occupied 1 time (8 channels assignment)
Automatic refresh device assignment:	Refer to 8.4 Device Assignments Example (P. 102) .
Special relay (M) assignment:	M0: Extension number setting flag for display M1: Measured value (PV)/Manipulated output value (MV) transfer M2: Extension number setting flag for setting
Data register (D) assignment:	D0: Measured value (PV) store of CH1 D1: Measured value (PV) store of CH2 D2: Measured value (PV) store of CH3 D3: Measured value (PV) store of CH4 D4: Measured value (PV) store of CH5 D5: Measured value (PV) store of CH6 D6: Measured value (PV) store of CH7 D7: Measured value (PV) store of CH8 D8: Manipulated output value (MV) store of CH1 D9: Manipulated output value (MV) store of CH2 D10: Manipulated output value (MV) store of CH3 D11: Manipulated output value (MV) store of CH4 D12: Manipulated output value (MV) store of CH5 D13: Manipulated output value (MV) store of CH6 D14: Manipulated output value (MV) store of CH7 D15: Manipulated output value (MV) store of CH8

■ Program operation

1. Store Measured value (PV) and Manipulated output value (MV) to a data register.
2. Write in Set value (SV) of CH1 to CH8.
 - CH1 set value (SV): 150.0 °C
 - CH2 set value (SV): 200.0 °C
 - CH3 set value (SV): 250.0 °C
 - CH4 set value (SV): 300.0 °C
 - CH5 set value (SV): 350.0 °C
 - CH6 set value (SV): 400.0 °C
 - CH7 set value (SV): 450.0 °C
 - CH8 set value (SV): 500.0 °C
3. Change the controller to the control RUN.

■ Sample program

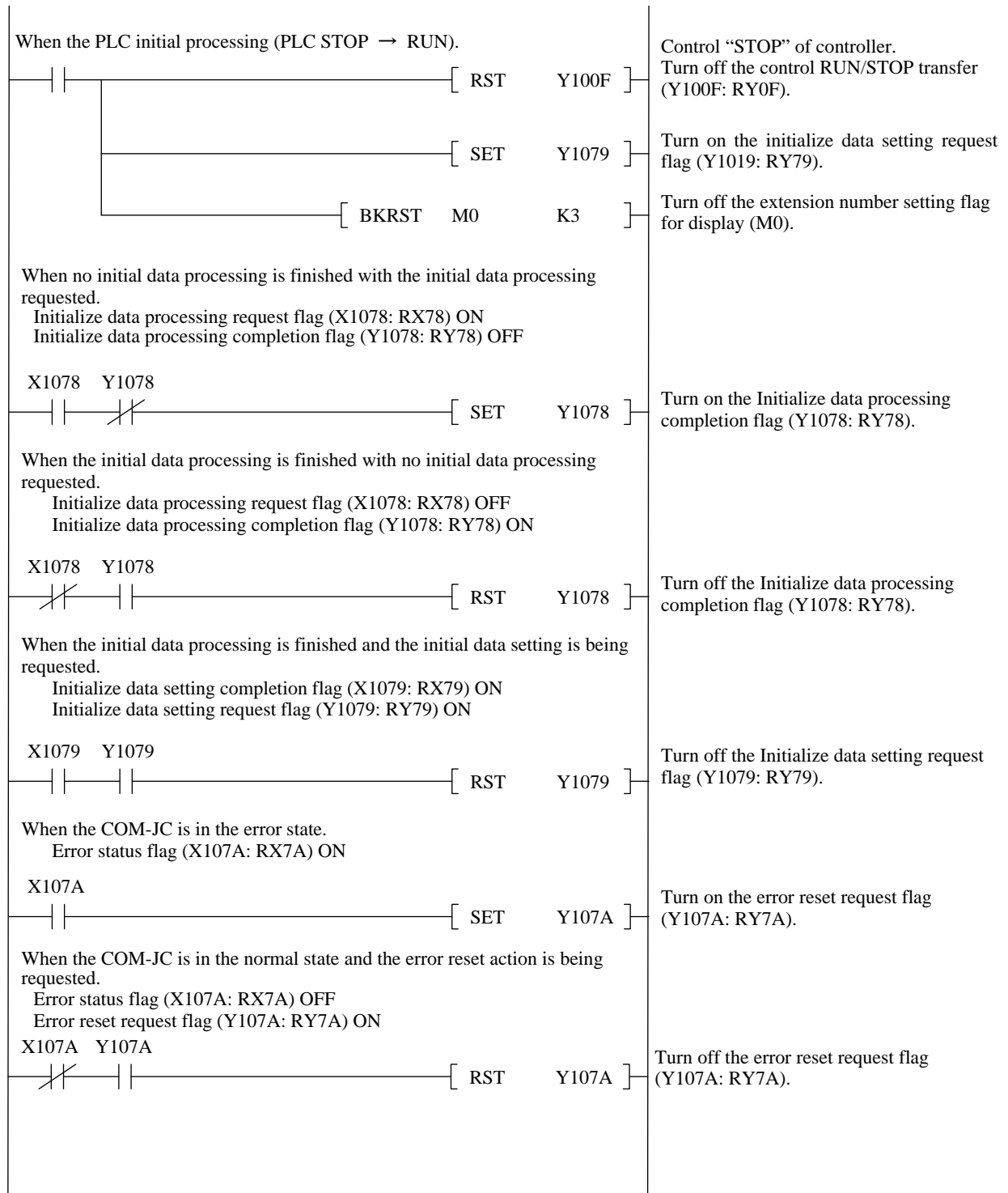

Continued on the next page.

Continued from the previous page.

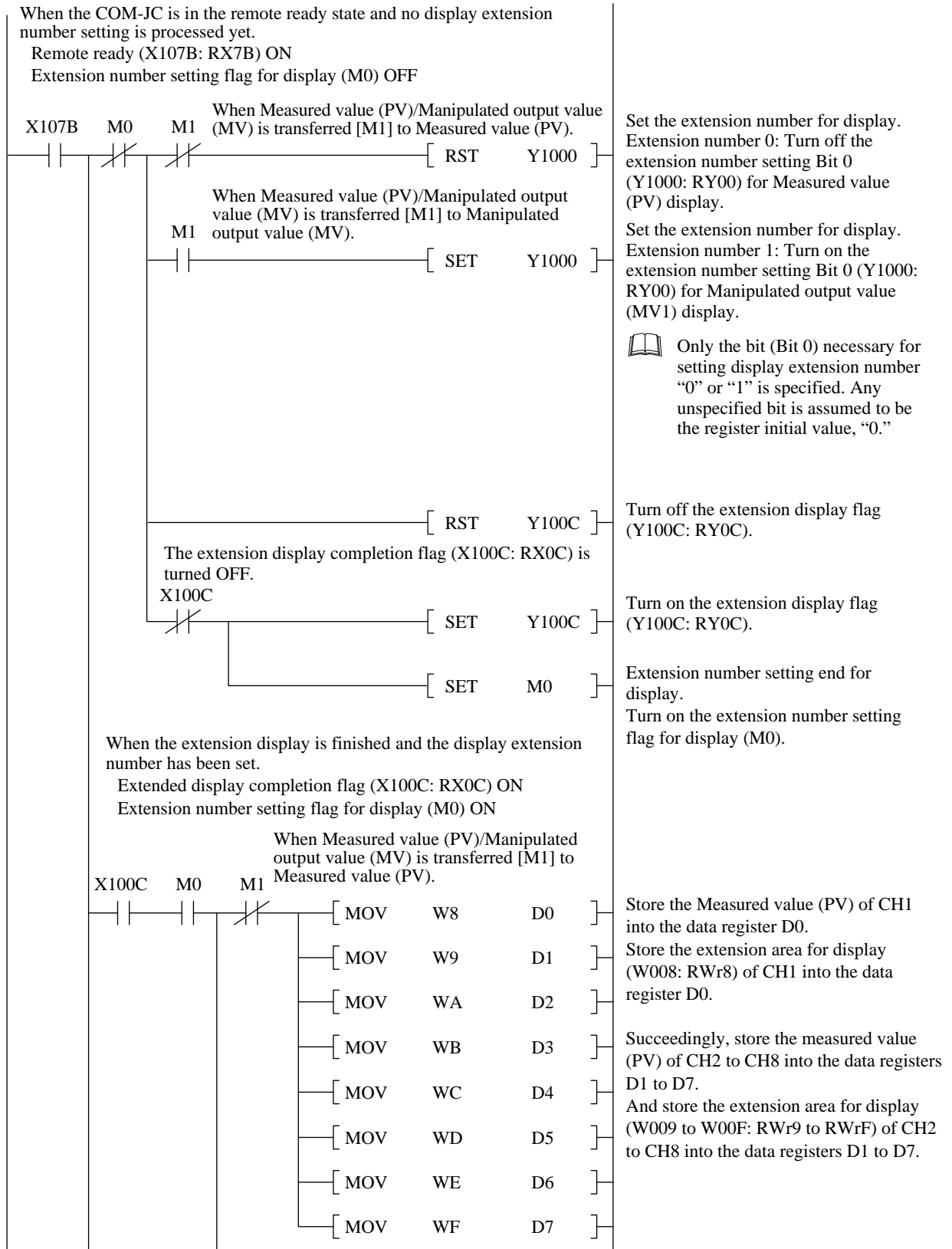

Continued on the next page.

Continued from the previous page.

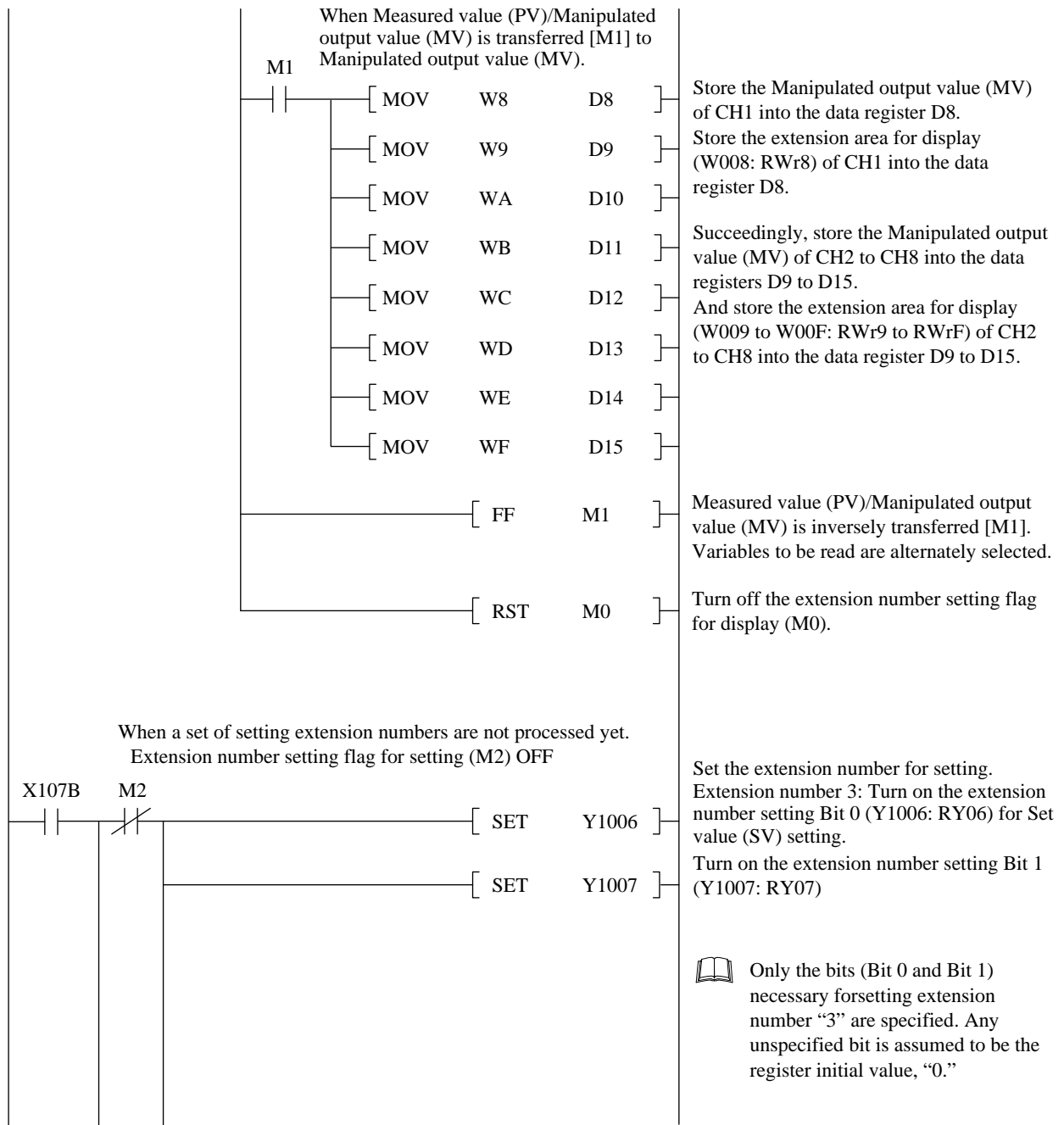

Continued on the next page.

Continued from the previous page.

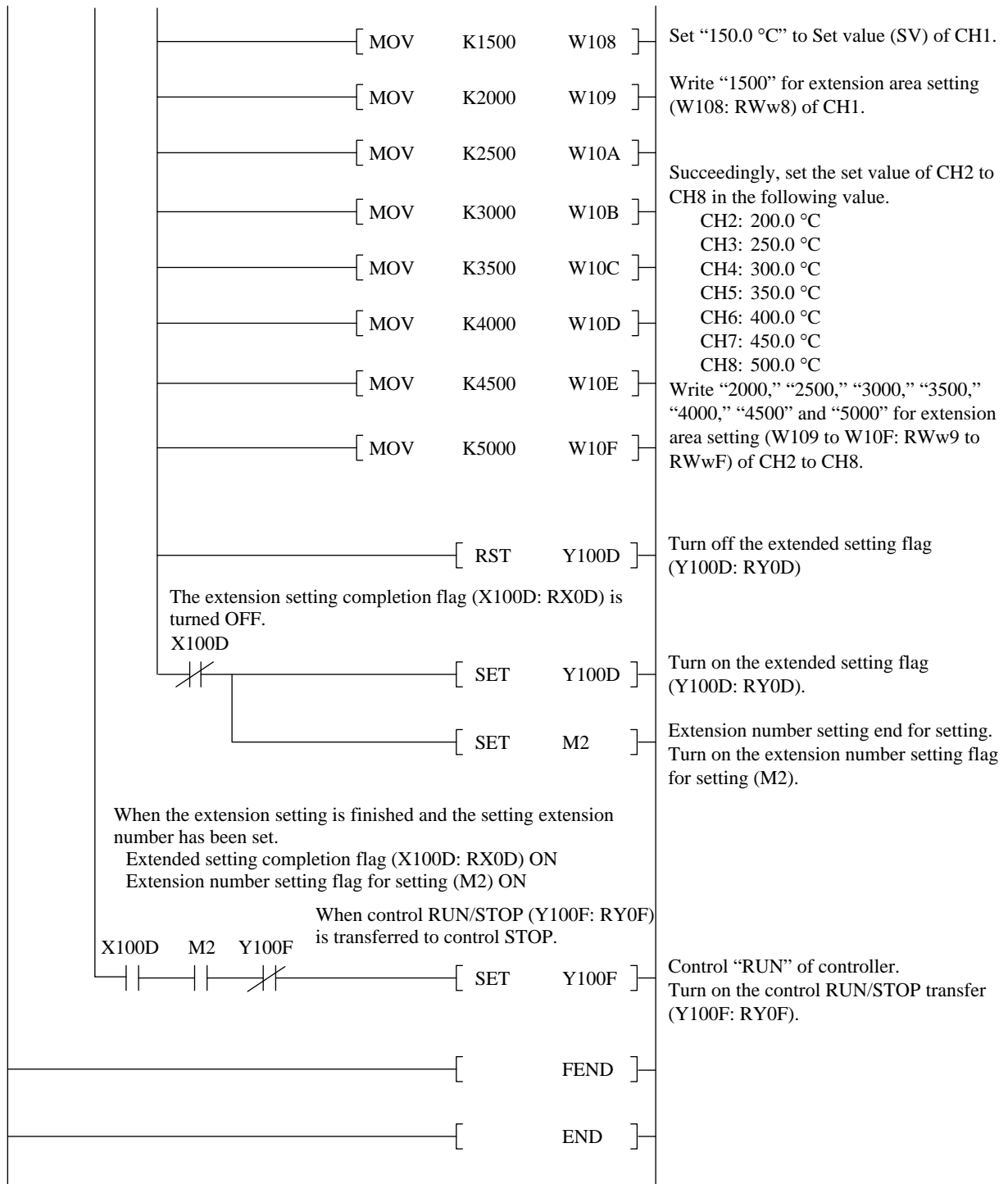

9. TROUBLESHOOTING

This section explains possible causes and solutions if any abnormality occurs in the instrument. For any inquiries or to confirm the specifications of the product, please contact RKC sales office or the agent.

If it is necessary to replace a device, always strictly observe the warnings below.



WARNING

- To prevent electric shock or instrument failure, always turn off the system power before replacing the instrument.
- To prevent electric shock or instrument failure, always turn off the power before mounting or removing the instrument.
- To prevent electric shock or instrument failure, do not turn on the power until all wiring is completed. Make sure that the wiring is correct before applying power to the instrument.
- To prevent electric shock or instrument failure, do not touch the inside of the instrument.
- All wiring must be performed by authorized personnel with electrical experience in this type of work.

CAUTION

Do not separate the mainframe from the terminal base with the power turned on. If so, instrument failure may result.

■ COM-JC

Problem	Possible cause	Solution
FAIL lamp flashes RUN lamp OFF SD/RD lamp OFF	No connection, disconnection, breakage or wrong wiring of CC-Link cable	Confirm the connection method or condition and connect correctly
	A termination resistor of CC-Link is not connected	Confirm the termination resistor, and connected correctly
	The number of occupied station/extended cyclic setting of the COM-JC differs from that of the master instrument (PLC).	Coincide the number of occupied station/extended cyclic setting of the COM-JC with that of the master instrument (PLC).
	The station number and communication speed settings of the COM-JC have been changed during communication.	<ul style="list-style-type: none"> • Turn on the power again. • Return the switch setting to the original setting.
FAIL lamp ON RUN lamp OFF SD/RD lamp OFF	The station number and communication speed settings of COM-JC are out of their setting ranges.	Set the station number and communication speed settings of COM-JC to values within their setting ranges.
FAIL lamp flashes RUN lamp ON SD/RD lamp flashes	The CC-Link version of the COM-JC differs from that of the master instrument (PLC).	Coincide the CC-Link version of the COM-JC with that of the master instrument (PLC). <ul style="list-style-type: none"> • 1 station occupied 1 time/ 4 stations occupied 1 time: CC-Link Ver. 1.10 • 4 stations occupied 2 times/ 4 stations occupied 4 times: CC-Link Ver. 2.00
RUN lamp flashes	Controller communication (Between COM-JC and controllers) is abnormal	<ul style="list-style-type: none"> • Check that the signal line of the COM-JC and controller are correctly connected. • Check that the communication setting (Address, protocol, communication speed and data bit configuration) of the COM-JC coincides with that of the controller. • Confirm whether a termination resistor is connected.
FAIL lamp ON	Hardware abnormality or software abnormality	Replace the COM-JC with a new one it in the abnormal state even with the power turned on again.

10. SPECIFICATIONS

■ CC-Link communication

Protocol: CC-Link Ver. 2.00/Ver. 1.10
Communication speed: 156 kbps, 625 kbps, 2.5 Mbps, 5 Mbps, 10 Mbps
Communication distance: Refer to table shown below

Communication speed	Maximum network length
10 Mbps	100 m
5 Mbps	200 m
2.5 Mbps	400 m
625 kbps	900 m
156 kbps	1200 m

Station number: 1 to 61 (4 stations occupied 1 time, 4 stations occupied 2 times
4 stations occupied 4 times)
1 to 64 (1 station occupied 1 time)

Connection cable: CC-Link dedicated cable Ver. 1.10 (Shielded twisted pair wire)

Number of occupied station/extended cyclic and CC-Link version:
 CC-Link Ver. 1.10: 1 station occupied 1 time, 4 stations occupied 1 time
 CC-Link Ver. 2.00: 4 stations occupied 2 times, 4 stations occupied 4 times

Connection method: Terminals

Termination resistor: External installation is necessary
 (Between the DA and DB terminals: 110 Ω 1/2 W)

Communication data length: Refer to table shown below

Number of occupied station/Extended cyclic	Remote Input/Output (RX/RX)	Remote register (RWr/RWw)	Number of CC-Link assignment channels
4 stations occupied 1 time	Input: 128-bit Output: 128-bit	RWr: 16-word RWw: 16-word	8channels or 16channels
4 stations occupied 2 times	Input: 224-bit Output: 224-bit	RWr: 32-word RWw: 32-word	16channels or 32channels
4 stations occupied 4 times	Input: 448-bit Output: 448-bit	RWr: 64-word RWw: 64-word	32channels or 64channels
1 station occupied 1 time	Input: 32-bit Output: 32-bit	RWr: 4-word RWw: 4-word	1channel or 2channels

■ Controller communication

Interface: Base on RS-485, EIA standard (Multi-drop connection is available.)

Protocol: Modbus-RTU

Synchronous method: Half-duplex start-stop synchronous type

Communication method: 2-wire system, half-duplex multi-drop connection

Communication speed: 9600 bps, 19200 bps, 38400 bps

Data bit configuration: Data 8-bit, Without parity bit, Stop 1-bit

Maximum connections: 31 controllers (SRZ module *) [Device address setting: 1 to 99]

* A combined total of up to 31 Z-TIO and Z-DIO modules can be connected in the SRZ.
 However, the maximum joinable number of functional modules of the same type is 16.

Connection method: Terminals

Termination resistor: Built-in terminal base of COM-JC
 [ON/OFF select with switch (120 Ω 1/2 W)]

■ **Self-diagnostic function**

Hardware error, RAM read/write error, Stack overflow:

Display: FAIL lamp ON
 Status: Hardware error flag [RXnF] “ON” on the CC-Link

Communication error, Memory backup error, Configuration error (Cannot recognize connection of a controller):

Display: RUN lamp flashes
 Status: Hardware error flag [RXnF] “ON” on the CC-Link
 (Memory backup error, Configuration error)
 Error status flag [RX(n+1)A] “ON” on the CC-Link
 (Communication error)

■ **General specifications**

Power supply voltage: 21.6 to 26.4 V DC [Including power supply voltage variation], (Rating 24 V DC)

Power consumption: 120 mA max. (at 24 V DC)

Rush current: 12 A or less

Insulation resistance: Between communication terminal and grounding:
 20 MΩ or more at 500 V DC
 Between power supply terminal and grounding:
 20 MΩ or more at 500 V DC
 Between power supply and communication terminals:
 20 MΩ or more at 500 V DC

Withstand voltage: Refer to table shown below

Time: 1 minute	①	②
① Grounding terminal		
② Power terminal	600 V AC	
③ Communication terminal	600 V AC	600 V AC

 CC-Link ground terminal is for CC-Link communication, and be not included in an above condition.

Power failure: A power failure of 20 ms or less will not affect the control action.

Memory backup: Backed up by non-volatile memory
 Number of writing: Approx. 100,000 times.
 Data storage period: Approx. 10 years

Vibration: Amplitude: < 1.5 mm (5 to 9 Hz)
 Acceleration: < 5 m/s² (9 to 150 Hz)
 Each direction of XYZ axes

Shock: Height 50 mm or less
 Each direction of XYZ axes (de-energized state)

Allowable ambient temperature:
 -10 to +50 °C

Allowable ambient humidity:
 5 to 95 %RH (Absolute humidity: MAX.W.C 29.3 g/m³ dry air at 101.3 kPa)

Installation environment conditions:
 Indoor use
 Altitude up to 2000 m

-
- Operating environment:** Avoid the following conditions when selecting the mounting location.
- Rapid changes in ambient temperature which may cause condensation.
 - Corrosive or inflammable gases.
 - Direct vibration or shock to the mainframe.
 - Water, oil, chemicals, vapor or steam splashes.
 - Direct air flow from an air conditioner.
 - Exposure to direct sunlight.
 - Excessive heat accumulation.

Weight: Approx. 220 g

Dimensions: 30 × 125 × 109.5 mm (W × H × D)

■ Standard

Safety standard: UL: UL61010-1
cUL: CAN/CSA-C22.2 No. 61010-1

CE marking: LVD: EN61010-1
OVERVOLTAGE CATEGORYII,
POLLUTION DEGREE 2,
Class II (Reinforced insulation)

EMC: EN61326-1

RCM: EN55011

MEMO



RKC INSTRUMENT INC.

HEADQUARTERS: 16-6, KUGAHARA 5-CHOME, OHTA-KU TOKYO 146-8515 JAPAN

PHONE: 03-3751-9799 (+81 3 3751 9799)

FAX: 03-3751-8585 (+81 3 3751 8585)

E-mail: info@rkcinst.co.jp

Website: <http://www.rkcinst.com/>