

Thank you for purchasing the RKC product. In order to achieve maximum performance and ensure proper operation of your new instrument, carefully read all the instructions in this manual. Please place this manual in a convenient location for easy reference.

This manual describes the handling precautions, mounting, wiring and specifications only. For the basic operations, see **COM-JC [For FB400/FB900] Quick Instruction Manual (IMR01Y11-ED)**. For detailed handling procedures and various function settings, please refer to separate **COM-JC [For FB400/FB900] Instruction Manual (IMR01Y06-ED)**.

The above manuals can be downloaded from our website:
URL: http://www.rkcinst.com/english/manual_load.htm

Product Check

COM-JC [For FB400/FB900] Installation Manual (this manual)	1
COM-JC [For FB400/FB900] Quick Instruction Manual (IMR01Y11-ED)	1
COM-JC [For FB400/FB900] Communication Data List (IMR01Y16-ED).....	1

Safety Precautions



- An external protection device must be installed if failure of this instrument could result in damage to the instrument, equipment or injury to personnel.
- All wiring must be completed before power is turned on to prevent electric shock, fire or damage to instrument and equipment.
- This instrument must be used in accordance with the specifications to prevent fire or damage to instrument and equipment.
- This instrument is not intended for use in locations subject to flammable or explosive gases.
- Do not touch high-voltage connections such as power supply terminals, etc. to avoid electric shock.
- RKC is not responsible if this instrument is repaired, modified or disassembled by other than factory-approved personnel. Malfunction can occur and warranty is void under these conditions.

CAUTION

- This product is intended for use with industrial machines, test and measuring equipment. (It is not designed for use with medical equipment and nuclear energy.)
- This is a Class A instrument. In a domestic environment, this instrument may cause radio interference, in which case the user may be required to take adequate measures.
- This instrument is protected from electric shock by reinforced insulation. Provide reinforced insulation between the wire for the input signal and the wires for instrument power supply, source of power and loads.
- Be sure to provide an appropriate surge control circuit respectively for the following:
 - If input/output or signal lines within the building are longer than 30 meters.
 - If input/output or signal lines leave the building, regardless the length.
- This instrument is designed for installation in an enclosed instrumentation panel. All high-voltage connections such as power supply terminals must be enclosed in the instrumentation panel to avoid electric shock by operating personnel.
- All precautions described in this manual should be taken to avoid damage to the instrument or equipment.
- All wiring must be in accordance with local codes and regulations.
- To prevent instrument damage or failure, protect the power line and the input/output lines from high currents with a protection device such as fuse, circuit breaker, etc.
- Prevent metal fragments or lead wire scraps from falling inside instrument case to avoid electric shock, fire or malfunction.
- Tighten each terminal screw to the specified torque found in the manual to avoid electric shock, fire or malfunction.
- For proper operation of this instrument, provide adequate ventilation for heat dispensation.
- Do not connect wires to unused terminals as this will interfere with proper operation of the instrument.
- Turn off the power supply before cleaning the instrument.
- Do not use a volatile solvent such as paint thinner to clean the instrument. Deformation or discoloration will occur. Use a soft, dry cloth to remove stains from the instrument.
- To avoid damage to instrument display, do not rub with an abrasive material or push front panel with a hard object.

NOTICE

- This manual assumes that the reader has a fundamental knowledge of the principles of electricity, process control, computer technology and communications.
- The figures, diagrams and numeric values used in this manual are only for purpose of illustration.
- RKC is not responsible for any damage or injury that is caused as a result of using this instrument, instrument failure or indirect damage.
- RKC is not responsible for any damage and/or injury resulting from the use of instruments made by imitating this instrument.
- Periodic maintenance is required for safe and proper operation of this instrument. Some components have a limited service life, or characteristics that change over time.
- Every effort has been made to ensure accuracy of all information contained herein. RKC makes no warranty expressed or implied, with respect to the accuracy of the information. The information in this manual is subject to change without prior notice.
- No portion of this document may be reprinted, modified, copied, transmitted, digitized, stored, processed or retrieved through any mechanical, electronic, optical or other means without prior written approval from RKC.

1. MOUNTING



To prevent electric shock or instrument failure, always turn off the power before mounting or removing the instrument.

1.1 Mounting Cautions

- (1) This instrument is intended to be used under the following environmental conditions. (IEC61010-1) [OVERVOLTAGE CATEGORY II, POLLUTION DEGREE 2]
 - (2) Use this instrument within the following environment conditions.
 - Allowable ambient temperature: -10 to +50 °C
 - Allowable ambient humidity: 5 to 95 % RH (Absolute humidity: MAX. W. C 29.3 g/m³ dry air at 101.3 kPa)
 - Installation environment conditions: Indoor use
Altitude up to 2000 m
 - (3) Avoid the following conditions when selecting the mounting location:
 - Rapid changes in ambient temperature which may cause condensation.
 - Corrosive or inflammable gases.
 - Direct vibration or shock to the mainframe.
 - Water, oil, chemicals, vapor or steam splashes.
 - Excessive dust, salt or iron particles.
 - Excessive induction noise, static electricity, magnetic fields or noise.
 - Direct air flow from an air conditioner.
 - Exposure to direct sunlight.
 - Excessive heat accumulation.
 - (4) Take the following points into consideration when mounting this instrument.
 - Ensure at least 50 mm space on top and bottom of the instrument for maintenance and environmental reasons.
 - Do not mount this instrument directly above equipment that generates large amount of heat (heaters, transformers, semi-conductor functional devices, large-wattage resistors).
 - If the ambient temperature rises above 50 °C, cool this instrument with a forced air fan, cooler, or the like. However, do not allow cooled air to blow this instrument directly.
 - In order to improve safety and the immunity to withstand noise, mount this instrument as far away as possible from high voltage equipment, power lines, and rotating machinery.
 - High voltage equipment: Do not mount within the same panel.
 - Power lines: Separate at least 200 mm.
 - Rotating machinery: Separate as far as possible.
 - (5) This instrument is permanently connected to equipment, please take the following points.
 - A switch or circuit-breaker shall be included in the building installation.
 - It shall be in close proximity to the equipment and within easy reach of the operator.
 - It shall be marked as the disconnecting device for the equipment.

1.2 Dimensions

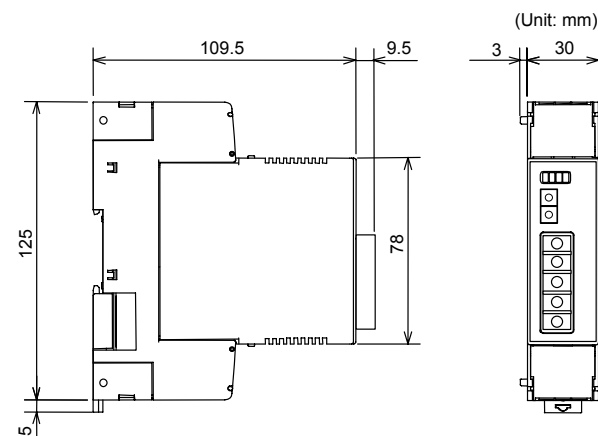

1.3 DIN rail Mounting

Mounting procedures

1. Pull down the mounting bracket at the bottom of the module (A). Attach the hooks on the top of the module to the DIN rail and push the lower section into place on the DIN rail (B).
2. Slide the mounting bracket up to secure the module to the DIN rail.

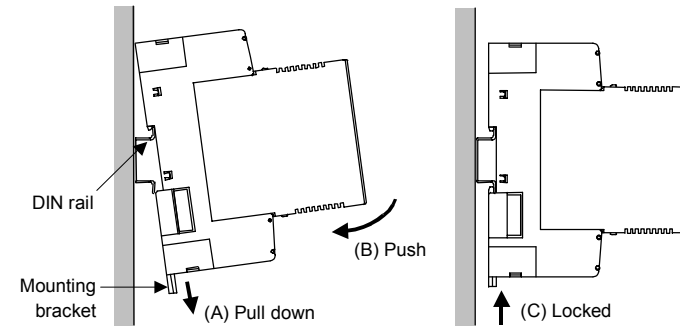

Removing procedures

Pull down a mounting bracket with a blade screwdriver (A). Lift the module from bottom, and take it off (B).

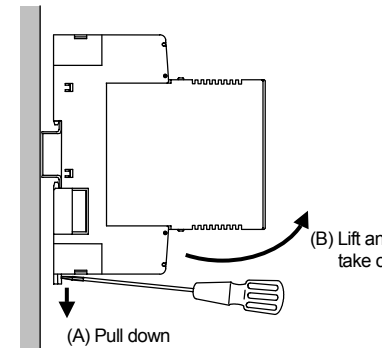

1.4 Panel Mounting

Mounting procedures

1. Pull down the mounting bracket (A) until locked and that a mounting hole appears.
2. Prepare one mounting bracket per module (B) sold separately (KSRX-55) and then insert it in the rear of the terminal board at top of the module until locked but a mounting hole does not disappear.
3. Mount each module directly on the panel with screws which are inserted in the mounting holes of the top and bottom mounting brackets.
Recommended tightening torque: 0.3 N·m (3 kgf·cm)

The customer needs to provide the M3 size screws. Select the screw length that matches the mounting panel.

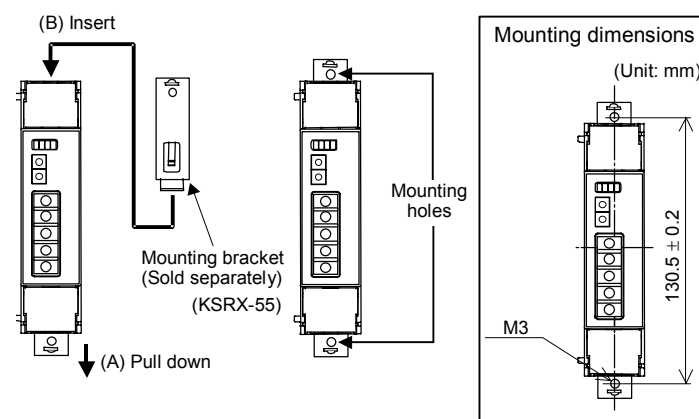

2. WIRING



To prevent electric shock or instrument failure, do not turn on the power until all the wiring is completed.

2.1 Wiring Cautions

- To avoid noise induction, keep communication signal wire away from instrument power line, load lines and power lines of other electric equipment.
- If there is electrical noise in the vicinity of the instrument that could affect operation, use a noise filter.
 - Shorten the distance between the twisted power supply wire pitches to achieve the most effective noise reduction.
 - Always install the noise filter on a grounded panel. Minimize the wiring distance between the noise filter output and the instrument power supply terminals to achieve the most effective noise reduction.
 - Do not connect fuses or switches to the noise filter output wiring as this will reduce the effectiveness of the noise filter.
- Power supply wiring must be twisted and have a low voltage drop.
- For an instrument with 24 V power supply, supply power from a SELV circuit.
- A suitable power supply should be considered in the end-use equipment. The power supply must be in compliance with a limited-energy circuits (maximum available current of 8 A).
- Use the solderless terminal appropriate to the screw size (M3).

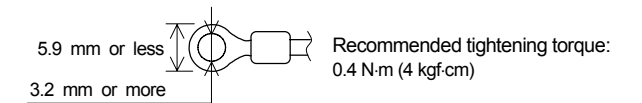

2.2 Terminal Configuration

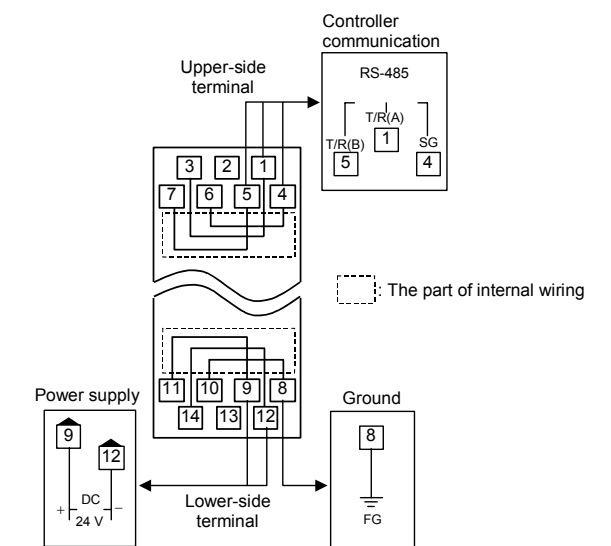

- As controller communication terminal Nos. 1, 4 and 5 are internally connected to terminal Nos. 3, 6 and 7, any terminals can be used.
- As ground and power supply terminal Nos. 8, 9 and 12 are internally connected to terminal Nos. 10, 11 and 14, any terminals can be used.
- Terminal No. 2 and No. 13 is not used.

2.3 Connection to PLC

Method to connect

The PLC (master station) and COM-JC make multi-drop connection in CC-Link dedicated cable Ver. 1.10.

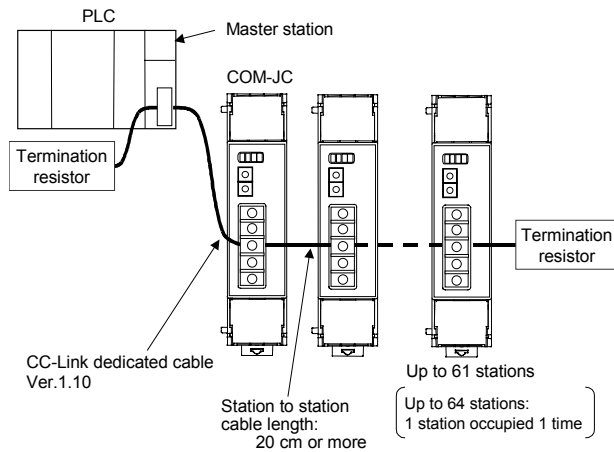

Communication speed and maximum transmitter distance

Communication speed	Station to station cable length	Maximum transmitter distance (maximum length of network)
10 Mbps	20 cm or more	100 m
5 Mbps		160 m
2.5 Mbps		400 m
625 kbps		900 m
156 kbps		1200 m

Terminal numbers and signal details

Terminal No.	Signal name	Symbol	Cable color
1	Data A	DA	Blue
2	Data B	DB	White
3	Data ground	DG	Yellow
4	Shield	SLD	Grounding wire (Shield)
5	Frame ground	FG	—

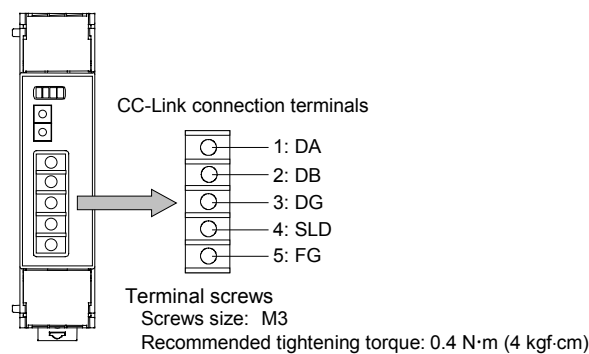

The CC-Link connecting terminal cannot do on-line installation or dismount for terminal block of dismount impossibility. The device cannot be replaced unless the link is set offline. In addition, FG (flame gland) terminal of terminal number 5 is FG in a CC-Link function, and it is not FG of instrument all.

Ground both ends of the shield wire on the twisted pair cable via the SLD or FG terminal of each module. In addition, the SLD terminal is internally connected with the FG terminal.

Do not ground the instrument together with other equipment. In addition, use grounding wires with across section of 2.0 mm² or more. (Ground resistance: 100 ohm or less)

For cable specifications, connection method and vendor, see the website of CC-Link Partner Association.

URL: <http://www.cc-link.org/>

Connection diagram

Always connect a termination resistor between the DA and DB terminals of the module to be located at the far end. Termination resistor: 110 Ω ± 5 % 1/2 W

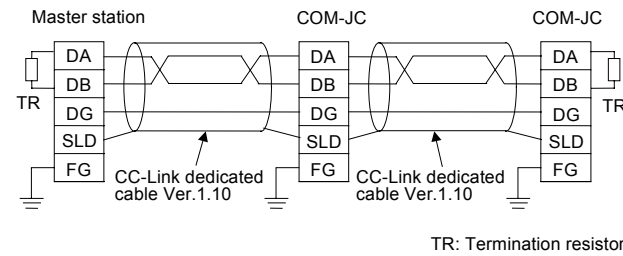

2.4 Connection to the Controllers

Conduct wiring between the COM-JC and controller (FB400/FB900) as shown in the following. (When conducting wiring to the FB400/FB900, always conduct wiring to the Communication 1 terminal.)

Connection diagram

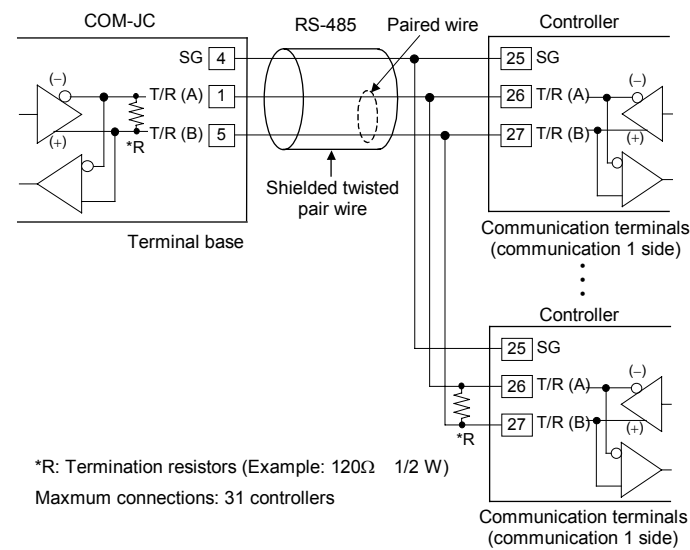

- The cable is provided by the customer.
- The termination resistor existing within the COM-JC can be connected or disconnected by the switch. (Factory set value: Termination resistor connected)

2.5 System Configuration Example

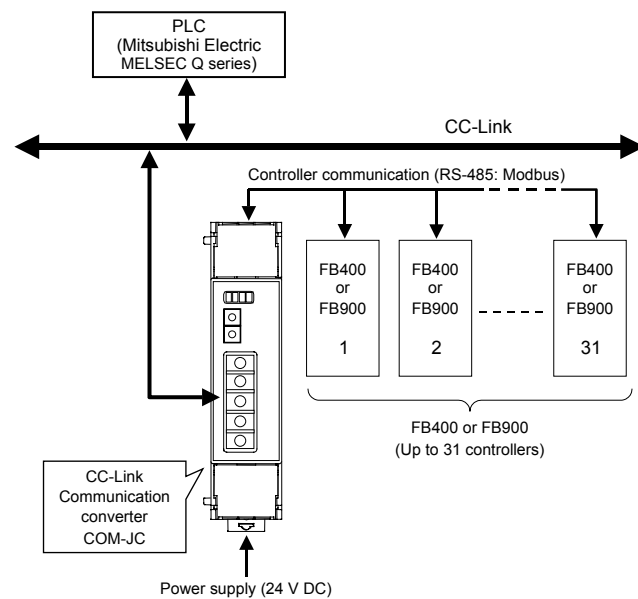

Relationship between number of occupied station/extended cyclic and number of controller connection

Number of occupied station/extended cyclic	Number of maximum connection of controller
1 station occupied 1 time	2 controllers
4 stations occupied 1 time	16 controllers
4 stations occupied 2 times	31 controllers

3. PARTS DESCRIPTION

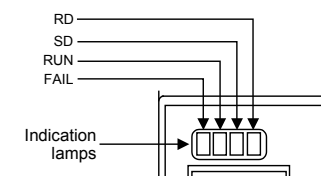
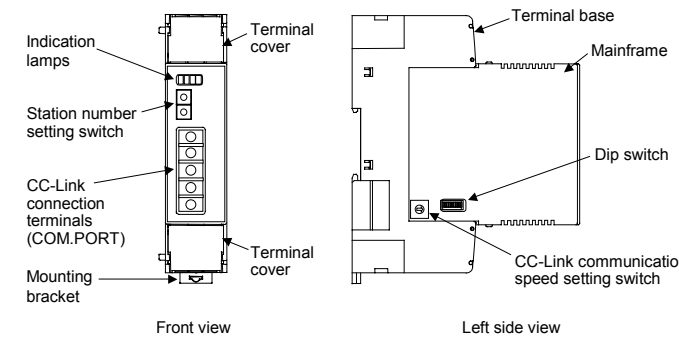

Indication lamps

Lamp	Color	Condition	Action
FAIL	[Red]	When instrument abnormally: • CC-Link setting error: • CC-Link operation error: • CC-Link setting is changed:	Turns on Turns on Flashes slowly Flashes rapidly
RUN	[Green]	When normally: • Operation error: • During controller communication initialization:	Turns on Flashes slowly Flashes rapidly
SD	[Green]	During CC-Link data send:	Turns on
RD	[Green]	During CC-Link data receive:	Turns on

CC-Link connection terminals

COM. PORT	Terminals for PLC (Master) connection
-----------	---------------------------------------

Switches

Station number setting switch	Set the station number for CC-Link
CC-Link communication speed setting switch	Set the communication speed for CC-Link
Dip switch	• Set the number of occupied station/extension cyclic for CC-Link • Set the communication speed for controller communication

Others

Terminal cover	Terminal covers above and below the COM-JC
Mounting bracket	• Used for the DIN rail mounting • When panel mounted, two mounting brackets are required for the upper and lower sides (one required for the upper side: separately sold).
Terminal base	Part of the terminal and base of COM-JC (There is the termination resistor setting switch in the inside of terminal base)
Mainframe	Part of the mainframe of COM-JC

4. SPECIFICATIONS

CC-Link communication

Protocol: CC-Link Ver. 1.10/Ver. 2.00
 Communication speed: 156 kbps, 625 kbps, 2.5 Mbps, 5 Mbps, 10 Mbps
 Station number: 1 to 61 (4 stations occupied 1 time, 4 stations occupied 2 times)
 Connection cable: CC-Link dedicated cable Ver. 1.10

Controller communication

Interface: Based on RS-485, EIA standard
 Protocol: Modbus-RTU
 Communication speed: 9600 bps, 19200 bps, 38400 bps
 Data bit configuration: Data 8-bit, Without parity, Stop 1-bit
 Maximum connections: 31 controllers (FB400/FB900)

General specifications

Power supply voltage: 24 V DC
 Power supply voltage range: 21.6 V DC to 26.4 V DC
 Power consumption: 120 mA max. (at 24 V DC)
 Rush current: 12 A or less
 Allowable ambient temperature range: -10 to +50 °C
 Allowable ambient humidity range: 5 to 95 %RH (Non condensing)
 Installation environment conditions: Indoor use, Altitude up to 2000 m
 Weight: Approx. 220 g

Standard

Safety standard: UL: UL61010-1
 cUL: CAN/CSA-C22.2 No.61010-1
 CE marking: LVD: EN61010-1
 EMC: EN61326
 C-Tick: AS/NZS CISPR11 (equivalent to EN55011)

5. MODEL CODE

COM-JC * □□ - □
 (1) (2)

- (1) Corresponding to the RKC temperature controller
 01: FB400/FB900
- (2) RUN/STOP logic selection
 1: 0: RUN
 1: STOP
 2: 0: STOP
 1: RUN

CC-Link is a registered trademark of Mitsubishi Electric Co. Ltd.
 Modbus is a registered trademark of Schneider Electric.
 Company names and product names used in this manual are the trademarks or registered trademarks of the respective companies.

RKC RKC INSTRUMENT INC. The first edition: JAN. 2005 [IMQ00]
 The third edition: JUN. 2007 [IMQ00]
 HEADQUARTERS: 16-6, KUGAHARA 5-CHOME, OHTA-KU TOKYO 146-8515 JAPAN
 PHONE: 03-3751-9799 (+81 3 3751 9799) E-mail: info@rkinst.co.jp
 FAX: 03-3751-8585 (+81 3 3751 8585) JUN. 2007